

M

IBM

Reference Manual

IBM 1401 Data Processing System

IBM

Reference Manual

IBM 1401 Data Processing System

MAJOR REVISION (April, 1962)

This edition, A24-1403-5, obsoletes A24-1403-4 and all earlier editions. Significant changes have been made throughout the manual, and this new edition should be reviewed in its entirety.

This edition also obsoletes these publications:

G24-1438 IBM 1401 Data Processing System Bulletin
Early Card Read Special Feature for IBM 1402
Card Read-Punch

G24-1458 IBM 1401 Data Processing System Bulletin
Processing Overlap

G24-1461 IBM 1401 Data Processing System Bulletin
Processing Overlap: Processing Time During
Magnetic Tape Operations

N24-0001 No. 1 Oct. 23, 1961

N24-0004 No. 2 Oct. 30, 1961

N24-0005 No. 3 Oct. 31, 1961

N24-0009 No. 4 Dec. 18, 1961

N24-0010 No. 5 Dec. 18, 1961

N24-0018 No. 6 Feb. 28, 1962

© 1960, 1961, 1962 by International Business Machines Corporation

Address comments regarding this publication to IBM Product Publications, Endicott, New York

Preface

This manual is a reference text for the IBM 1401 Data Processing System. It provides a detailed explanation of operation codes and the function of the system's components. The reader should have a knowledge of the 1401 system and programming techniques. The reader should be familiar with the General Information Manual, IBM *1401 Data Processing System*, form D24-1401, and the various publications on applied programming material, such as Symbolic Programming System (SPS) and *Autocoder*.

The manual is divided into these sections:

- operation codes
- operating features
- systems timing
- appendix

The sections are independent and need not be used in the order in which they appear.

This manual is intended for the use of programmers and systems personnel who have a general knowledge of the IBM 1401 Data Processing System and who require a reference text for detailed information. The manual can also be used as a training aid in the instruction of programmers and operators.

It should be noted that other publications referenced in the manual are, in most cases, prerequisites for a complete understanding of the material presented in this reference manual.

Contents

Introduction	7	IBM 1407 Console Inquiry Station	70
The Stored Program	7	IBM 1407 Console Inquiry Station Instructions	71
Other Input-Output Units for the IBM 1401 System	7	Special Features	74
The IBM 1401 Used with Other IBM Systems	8	Multiply-Divide Feature	74
Physical Features	9	Increased Core Storage	76
Solid-State Circuitry	9	Read Release and Punch Release Feature	78
Advanced Systems Design	9	Punch Feed Read Feature	80
IBM 1401 Processing Unit	9	Print Storage Feature	82
IBM 1402 Card Read-Punch	10	Additional Print Control Feature	82
IBM 1403 Printer	11	Expanded Print Edit Feature	82
Magnetic-Core Storage	11	Indexing Feature	84
Magnetic-Tape Storage	12	Store Address Register Feature	85
Magnetic-Disk Storage	12	Move Record Feature	86
Language	13	High-Low-Equal Compare Feature	86
Processing	14	Sense Switches Feature	87
Stored Program Instructions	15	Compressed Tape Operations Feature	87
Addressing	18	Column Binary Feature	89
Operation of IBM 1401 Registers	19	Numerical Print Feature	94
IBM 1401 Programming Systems	23	Interchangeable Chain Cartridge Adapter	94
Symbolic Languages	23	Interchangeable 51-Column Read Feed	95
IBM 1401 Symbolic Programming System (SPS)	23	Early Card Read Feature	97
IBM 1401 Autocoder	23	Processing Overlap Feature	97
Input-Output Control System (IOCS)	27	Address Modification	106
IBM 1401 Report Program Generator (RPG)	27	Address Modification Without Indexing Feature	106
Operation Codes	28	Address Modification with Indexing Feature	108
Arithmetic Operations	28	Operating Features	109
Logic Operations	32	IBM 1401 Console Keys, Lights, and Switches ..	109
Clear, Move, Load, and Word Mark Operations	35	Auxiliary Console	116
Editing	41	Auxiliary Console Switches	116
Input-Output Operations	44	IBM 1402 Card Read-Punch Operating Keys, Lights, and Switches	118
Card Read Instructions	44	IBM 1403 Printer Operating Keys, Lights, and Switches	119
Punch Instructions	45	Printer Controls	119
Print Instructions	46	Carriage Controls	120
Combination Instructions	48	Tape-Controlled Carriage	123
Document Control Instructions	51	IBM 1405 Disk Storage Unit Indicator Lights ..	128
Magnetic Tape	53	IBM 1407 Console Inquiry Station Keys and Lights	129
Data Flow	53	Operating Pointers	130
Magnetic Tape Characteristics	53	IBM 729 and 7330 Magnetic Tape Units Operating Keys and Lights	134
Tape Units	55	Operating Pointers	135
IBM 729 Magnetic Tape Unit	55	Console Operation	136
IBM 7330 Magnetic Tape Unit	55	Console Inquiry Station Operation	136
Tape Intermix	55	Restart Procedures	138
Tape Checking	56		
Magnetic-Tape Operations	57		
Tape Instructions	57		
IBM RAMAC® 1401 System	63		
IBM 1405 Disk Storage Instructions	65		

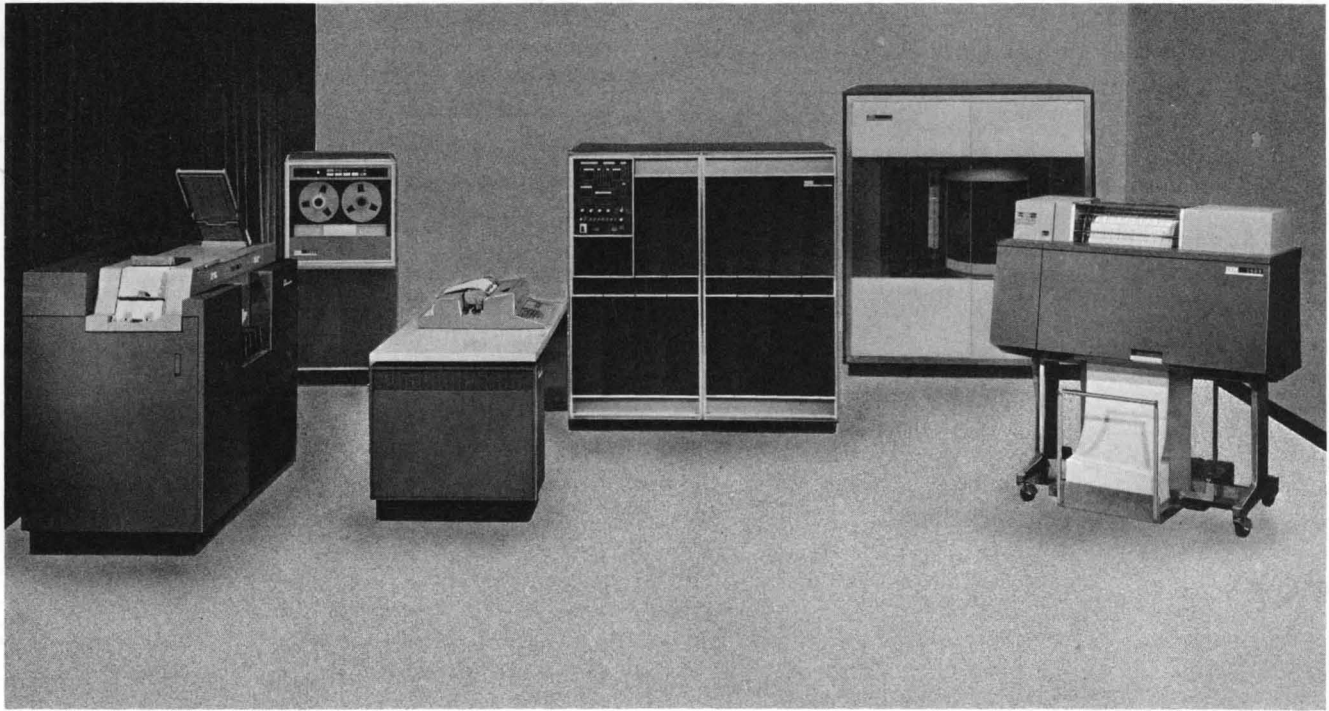

Figure 1. IBM RAMAC 1401 Data Processing System

Timing	140
Timing Input and Output Operations	140
Simultaneous Input-Output Operations	144
Processing Time	149
Tape Processing Time	152
Processing Overlap Timing	156
Disk Storage Access Time	158
Total Job Time	159

Appendix	160
Form Design	160
Program Loading Routine	164
Clear Storage Routine	165
Multiplication and Division Subroutines	166
IBM 1401 Operation Codes	169
IBM 1401 Character Code Chart in Collating Sequence ..	170
Index	171

IBM 1401 Data Processing System

As the recordkeeping requirements of business and industry continue to mount, the need for a data processing system that can be expanded to meet these requirements becomes apparent. A system is desired that can fill present needs, and that can expand as the burden of recordkeeping increases. Large-scale systems and small-scale systems are available, but a gap existed where no system seemed to do processing on an economical job-cost basis.

To fill this gap, IBM developed the IBM 1401 Data Processing System (Figure 1). The IBM 1401 is a solid-state, high-speed processing system with the program flexibility of larger systems.

The 1401 provides system configurations to meet the requirements for processing unit records, magnetic tape and magnetic disk records, and character-sensed documents.

The 1401 system provides high-speed input-output and arithmetic and logical ability, with the advantages of stored-program techniques. Various methods of programming are available. Some of the methods are: the easy-to-use actual language, the symbolic programming system (SPS) of mnemonic instructions, and IBM 1401 *Autocoder*.

The IBM 1401 Processing Unit handles variable-length alphanumerical data and instructions. This means no space is wasted by filling in fixed-length words.

Variable word length, high internal processing speed, fast input and output, powerful editing ability, and direct accumulation in storage make the IBM 1401 Data Processing System an efficient and valuable tool to meet today's data processing requirements.

IBM 1401 Data Processing Systems can be considered in three basic concepts: card systems, tape systems, and RAMAC® systems.

IBM 1401 card systems are planned for procedures involving large volumes of card documents as source data and output, with particular advantage to applications requiring re-entry data.

IBM 1401 tape systems are for handling magnetic tape, with all the advantages of compact record handling and storage for high-speed data processing.

IBM RAMAC 1401 systems permit rapid access to large volumes of repetitive data without the necessity of processing large card volumes or sorting tape records.

The Stored Program

The IBM 1401 performs its functions by executing a series of instructions at high speed. A particular set of instructions, designed to solve a specific problem, is known as a *program*. Because the 1401 stores its instructions internally, it is called a *stored program* system.

The 1401 normally executes instructions sequentially. But sometimes it is necessary to skip over a particular group of instructions, or otherwise change the sequence of the program. Branch instructions are provided in the system to make it possible to alter the program and take the next instruction from another area of the stored program. This feature also makes it possible to repeat an instruction, or group of instructions, as often as desired.

A series of programmed tests determines the logical path of the program. These tests are made at various points in the program to control the course of program step execution for specific conditions that can arise during processing.

Other Input-Output Units for the IBM 1401 System

To meet the ever increasing needs of business for fast, economical processing of data, the IBM 1401 Data Processing System can accept data made available to it in a variety of forms. Besides the normal input in the form of punched cards and magnetic tape, other devices that greatly increase the efficiency and flexibility of the 1401 have been provided. These units make it possible to read punched paper tape, magnetic ink characters, and printed characters, and to transmit data between 1401's or a 1401 and a tape transmission terminal.

The IBM 1011 Paper Tape Reader enables the direct input of data punched in paper tape into the 1401 system. Present day accounting and data processing practices are such that in many cases the source data for a central data processing system originates at locations remote from the central system. The ease and economy in transmitting punched paper tape make it an ideal medium for this type of reporting. A concise description of the 1011 including operating features, control panel summary, and IBM 1401 operation codes is found in the General Information Manual, IBM 1011 *Paper Tape Reader*, form D24-1044.

The IBM 1419 Magnetic Character Reader serves as a means of input to the 1401 system. This merging of machines increases flexibility and control in banking operations. Thus, magnetically-inscribed characters are read by the magnetic character reader and sent to 1401 core storage for processing. A full description of the 1419, including operating features and IBM 1401 operation codes, is included in the General Information Manual, *IBM 1219 Reader Sorter and IBM 1419 Magnetic Character Reader*, form D24-9000.

Re-entry documents can be read directly into the core storage unit of the 1401 by using the IBM 1418 Optical Character Reader as an input device. This means the elimination, in many cases, of preparing data for systems use when it is returned with a remittance. In many applications, this allows all functions necessary for processing data, from source document through the final report, to be accomplished in one operation. The use and functions of the 1418 are described in the Reference Manual, *IBM 1418 Optical Character Reader*, form A24-1418.

Many businesses with decentralized accounting operations have data processing installations at branch offices as well as at the headquarters location. The source data received from the branch offices enables the central office to prepare consolidated reports to meet their accounting needs. The IBM 1009 Data Transmission Unit allows high-speed, two-way communication between two IBM 1401 Data Processing Systems or between a 1401 and an IBM 7701 Magnetic Tape Transmission Terminal. The operation and functioning of the 1009 is described in the Reference Manual, *IBM 1009 Data Transmission Unit*, form A24-1039.

The IBM 7701 Magnetic Tape Transmission Terminal provides communication between outlying tape installations and a central data processing system, without intermediate conversion steps. Straight-line data flow from a 1401 tape system to a large-scale system such as an IBM 700 or 7000 series data processing system is now a fact. This development results in a fast, economical collection, processing, and return of data not previously possible. The functions and operating features of the 7701 are described in the Reference Manual, *IBM 7701 Magnetic Tape Transmission Terminal*, form A22-6527.

The IBM 1404 Printer is another output medium for the 1401 system. It is a combination printer capable of processing either separate card documents or continuous forms. Under control of the 1401 stored program, and the tape-controlled carriage, this unique

printer can process continuous forms at a rated speed of 600 lines per minute; or it can print on card documents at a maximum rate of 800 cards per minute. The 1404 can process cards ranging in size from 51 columns to 160 columns. It can also process two cards (either 51- or 80-columns) at a time. As many as 25 lines of data, either from 1401 core storage or from the card itself, can be printed on each card. Instructions, as well as the functional and operational characteristics, are covered in the 1401 Data Processing System bulletin, *IBM 1404 Printer*, form G24-1446.

Today's modern business requires fast, efficient and inexpensive intercommunication of data between branch, or field, locations and the central, or home, office. The IBM 1012 Tape Punch provides this means of communication and meets all these requirements.

The IBM 1012 Tape Punch, connected to an IBM 1401 Data Processing System, is an ideal medium for recording data processed at remote locations. Data punched in paper or Mylar* tape can be transmitted quickly and inexpensively to a central location by common carrier lines.

At the central location, the data recorded in the tape can be converted to punched cards or used as direct input to a central data processing system. A detailed description of the IBM 1012, including operating features and IBM 1401 operation codes, are found in the General Information Manual, *IBM 1012 Tape Punch*, form D24-1077.

The IBM 1401 Used with Other IBM Systems

IBM 7070 Data Processing System

The IBM 1401 Data Processing System has additional flexibility when it is used with the tape-oriented configuration of the IBM 7070 Data Processing System. The 1401 can produce, edit, sort, print, punch, and further manipulate tape data used by the 7070, thus providing more time for the operations that are more efficient and practical for each system.

IBM Scientific Data Processing Systems

The column binary feature enables the 1401 to process card and tape data recorded in binary form. This ability makes the 1401 especially useful as an auxiliary system for the IBM 704, IBM 709, and IBM 7090 Data Processing Systems.

*Trademark of E. I. duPont de Nemours Company, Inc.

Solid-State Circuitry

Transistorization of IBM 1401 components is a significant design characteristic. Transistors are relatively inexpensive, are easy to maintain, and increase reliability in the system (Figure 2). Space requirements, heat dissipation, and power requirements are carefully controlled.

The components that require operator attention are conveniently located.

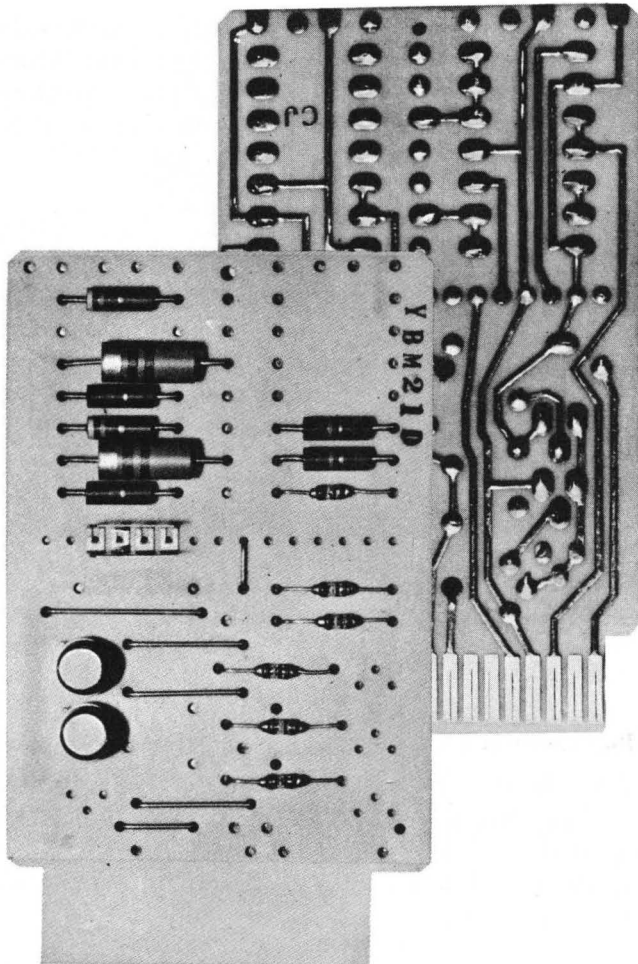

Figure 2. Transistor Cards

Advanced System Design

Advanced system design makes the IBM 1401 a complete, independent, accounting system. But it can also perform low-cost direct input and output, and auxiliary tape operations for large-scale data processing systems.

The entire system is controlled by the stored program. Timesaving features, such as the powerful editing function, and the elimination of control panels, provide increased flexibility for application development. The ability to use magnetic tape means economy in recording, transporting, and storing large volumes of information in compact form.

IBM 1401 Processing Unit

The IBM 1401 Processing Unit (Figure 3) contains the core storage and circuitry that perform the machine logic.

Storage capacity is 1400, 2000, 4000, 8000, 12,000 or 16,000 alphanumerical characters of 8-bit core storage. These eight bits consist of six bits for binary-coded decimals, a check bit, and an eighth bit for field definition.

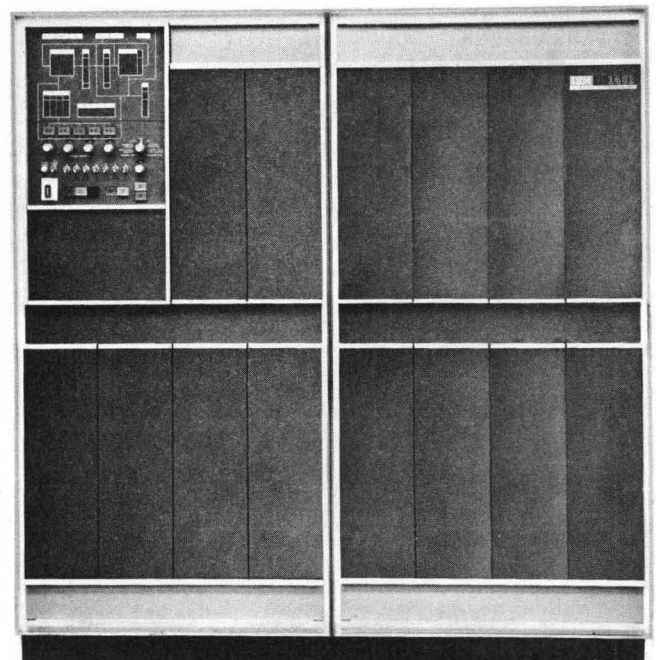

Figure 3. IBM 1401 Processing Unit

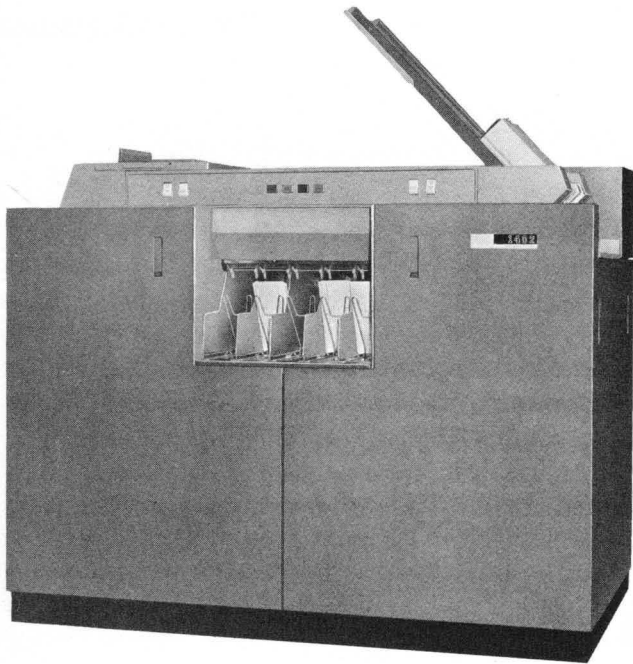

Figure 4. IBM 1402 Card Read-Punch

IBM 1402 Card Read-Punch

The IBM 1402 Card Read-Punch (Figure 4) provides the system with simultaneous punched-card input and output. This unit has two card feeds. The read section has a rated reading speed of 800 cards per minute. Actual card speed realized is governed by the stored program instructions. The read feed is equipped with a device for large-capacity loading, called a *file feed*. With the file feed device, the read feed can be loaded with as many as 3,000 cards.

The cards pass through the read side of the machine 9-edge first, face down. The feed path is from right to left, past two sets of brushes (Figure 5). The read check station reads 80 columns of the card to establish a hole count for checking purposes. The read station also reads 80 columns, proves the hole count, and directs the data into storage.

The punch section has a rated speed of 250 cards per minute. The card hopper capacity is 1,200 cards. Cards feed 12-edge first, face down. The feed path is left to right. Cards pass a blank station, a punch station, and a read station (Figure 5). The punch station consists of 80 punch magnets for recording information. The punch read station has 80 brushes that read the data punched in the card for a hole-count check.

The IBM 1402 Card Read-Punch is equipped with five radial type stackers (Figure 6), with a capacity of 1,000 cards each. Cards from each feed can be program-directed to three of the five pockets.

The cards from the read side go to the NR (normal read) pocket unless program-directed to pockets 1 or 2. The cards from the punch side go to the NP (normal punch) pocket unless program-directed to pockets 4 or 8.

The center pocket (8/2) can receive cards from either feed. However, card merging can be accomplished only under certain, very limited conditions.

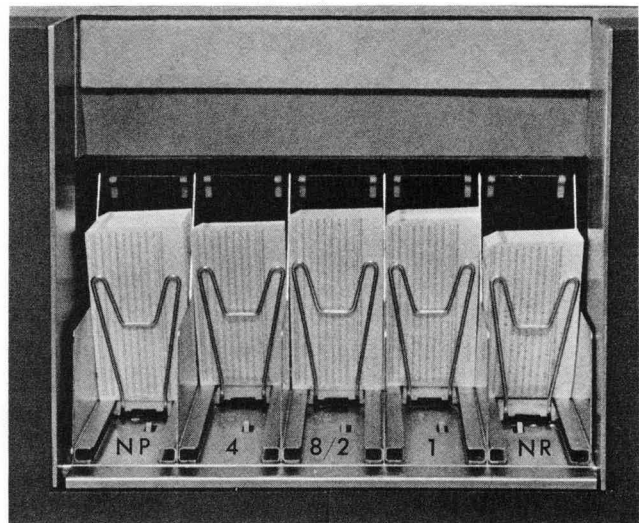

Figure 6. Radial Stackers

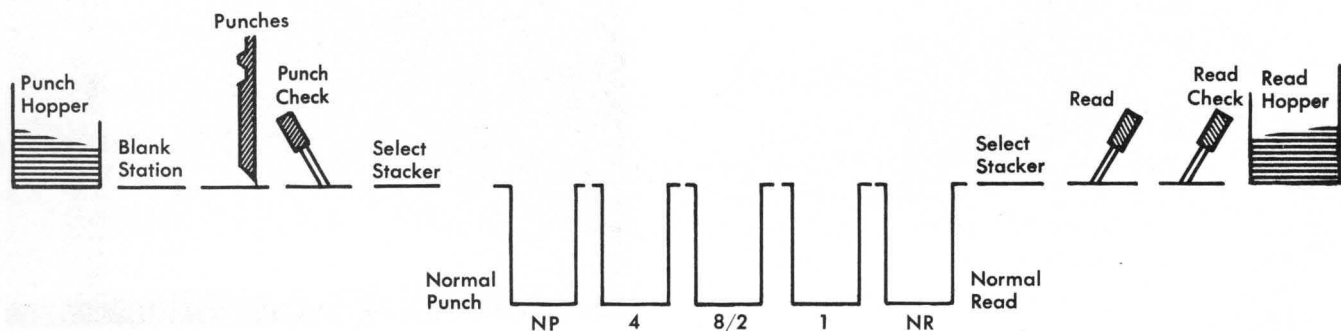

Figure 5. IBM 1402 Card Feed Schematic

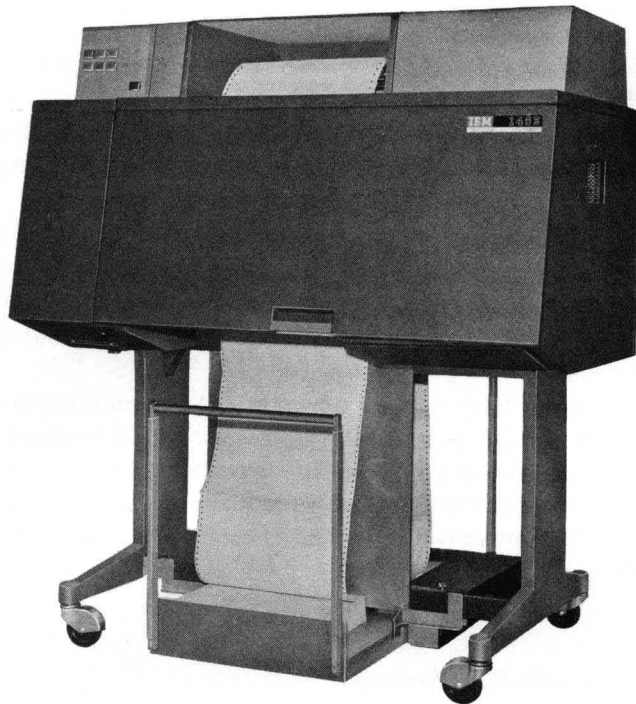

Figure 7. IBM 1403 Printer

IBM 1403 Printer

The IBM 1403 Printer (Figure 7) is another output medium for the IBM 1401 Data Processing System. This unit has a rated printing speed of 600 lines per minute. The standard printing capacity is 100 positions, with an additional 32 positions available as a special feature.

Each position can print 48 different characters: 26 alphabetic; 10 numerical; and 12 special characters (&, . □ - \$ * / % # @ ≠).

Vertical spacing and skipping are initiated by the stored program. Horizontal spacing is 10 characters to the inch. Vertical spacing of either six or eight lines to the inch can be manually selected by the operator. The paper transport mechanism for line spacing is a single-speed, tape-controlled carriage in the IBM 1401 card system, Model A. Other models (B, C, and D) use a dual-speed, tape-controlled carriage that permits skipping at the rate of 75 inches per second for skips of more than 8 lines, as compared to the single-speed carriage that has a constant speed of 33 inches per second for all skips.

METHOD OF PRINTING

The alphabetic, numerical, and special characters are assembled in a chain (Figure 8). As the chain travels in a horizontal plane, each character is printed as it is positioned opposite a magnet-driven hammer that presses the form against the chain.

As each hammer magnet is energized, it is checked against the corresponding position in the print area

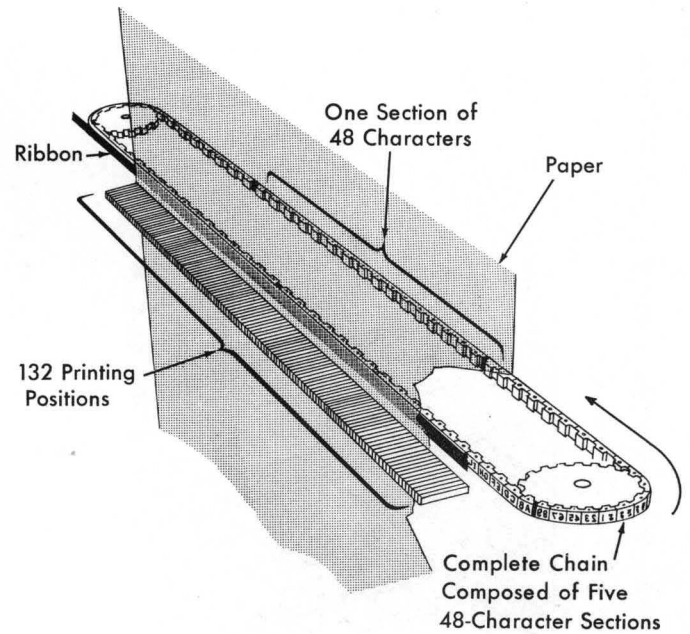

Figure 8. Printing Mechanism Schematic

of core storage to insure that printed output is accurate. Also the machine checks to insure that the character is printed in the correct print position, that only valid characters are printed, and that over-printing does not occur.

Magnetic-Core Storage

The IBM 1401 Data Processing System uses magnetic-core storage for storing instructions and data (Figures 9 and 10). All data in core storage is instantly avail-

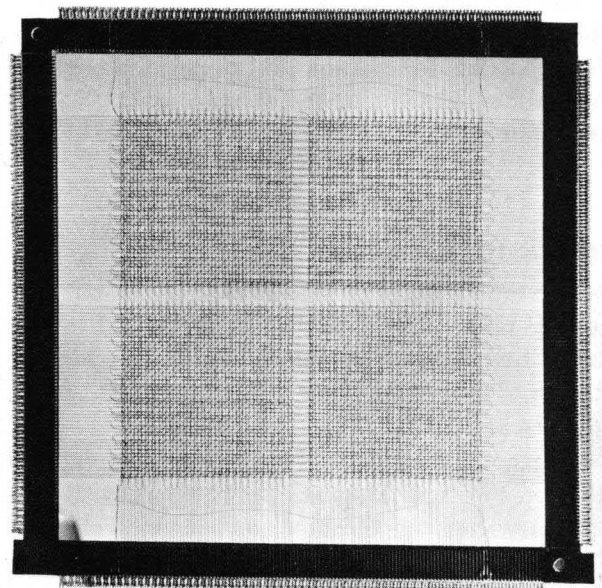

Figure 9. Magnetic Core Storage Unit

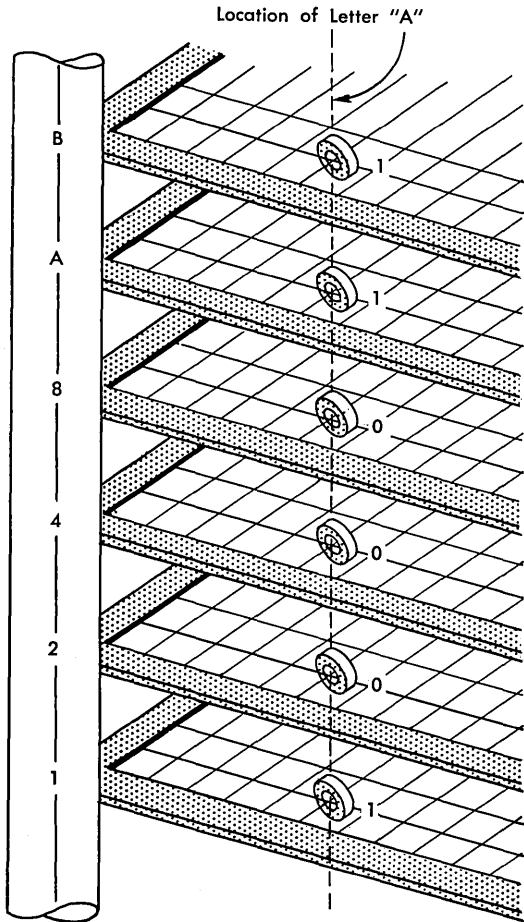

Figure 10. The Letter A Represented in Magnetic Core Storage

able, and the special design of the core-storage unit makes each position individually *addressable*. This means an instruction can designate the exact storage locations that contain the data needed for that step.

The physical make-up of each core-storage location makes it possible for the IBM 1401 to perform arithmetic operations directly in the storage area. (This is called *add to storage logic*.)

Magnetic-Tape Storage

Magnetic tape is made of plastic material, coated with a metallic oxide. It can be easily magnetized in tiny spots, so that patterns of these magnetized spots are codes for digits, alphabetic characters, and special characters.

Data can be read from a variety of sources, and written on the tape. Magnetic spots, representing information written on the tape, remain until changed by positive action.

This means that besides being used as data storage, this data itself can be part of input and output.

This makes magnetic tape an ideal storage medium for a large volume of data, because there is no limit to the amount of information that can be kept permanently. The reels of tape can be removed from the system and filed. They can also be transported from place to place and used in other systems.

Data stored on magnetic tape is read sequentially. The data processing system can search the tape to find the data to be used. Program steps can be stored on magnetic tapes, which are commonly used to set up a *library* or file of procedures.

Another advantage of magnetic-tape storage is that a reel of tape, produced as an output of a procedure, can be removed from the data processing system. Reports can be written using an independent unit, while the data processing system proceeds with the next program to be performed.

Magnetic-Disk Storage

Magnetic disks are thin metal disks, two feet in diameter, that are coated on both sides with a ferrous oxide recording material. These disks are mounted on a vertical shaft, and are separated from one another. As the shaft revolves, it spins the disks at 1200 rpm.

Information is recorded on disks in the form of magnetized spots located in concentric tracks on each disk surface.

At the side of the stack of disks (Figure 11), one or more access arms can move to any desired track on any disk under stored-program control. Magnetic recording heads mounted on the access arms write or read information as directed by the program. Each access arm is forked so that when it enters the stack of spinning disks, a recording head is carried to both sides of a disk. Thus, it is possible to read or write on either surface of a disk.

The magnetic disk can be used repetitively. Each time new information is stored in a track, it erases the data formerly stored there. Records can be read from disks as often as desired until they are written over or erased.

In addition to providing increased storage capacity, magnetic-disk storage units permit the processing of data on a random basis. Because any record on any track is addressable, the IBM 1401 Processing Unit has access to any record in the disk-storage unit. This random accessibility is the key to the in-line approach to data processing. It eliminates the necessity of accumulating transactions of a like kind (batching) before entering them. Transactions can be entered as they occur — regardless of sequence. In less than a second, the 1401 program can seek a record, update it, and

return the updated record to the storage unit. Also, the 1401 can process other data within core storage while the access mechanism searches for a record.

Language

In the punched-card area of data processing, the language of the machine consists of holes punched in a card. As data processing needs increase, the basic card language remains the same. But in the transition from unit-record systems to the IBM 1401 Data Processing System, and from there to computer systems, another faster, more flexible machine language emerges.

Just as each digit, letter in the alphabet, or special character is coded into a card as a punched hole or a combination of punched holes, it is coded into magnetic storage as a pattern of magnetized spots.

Many different code patterns can be set up. The internal code used in the IBM 1401 Data Processing System is called *binary-coded decimal*. All data and instructions are translated into this code as they are stored. No matter how information is introduced into the system (most commonly by means of punched cards or magnetic tape), the binary-coded-decimal code is used in all data flow and processing from that point on, until it is translated into printed output as reports and documents are written, or converted to punched-card code, for punched-card output. Converting input data to the 1401 internal code, and subsequently reconverting, is completely automatic.

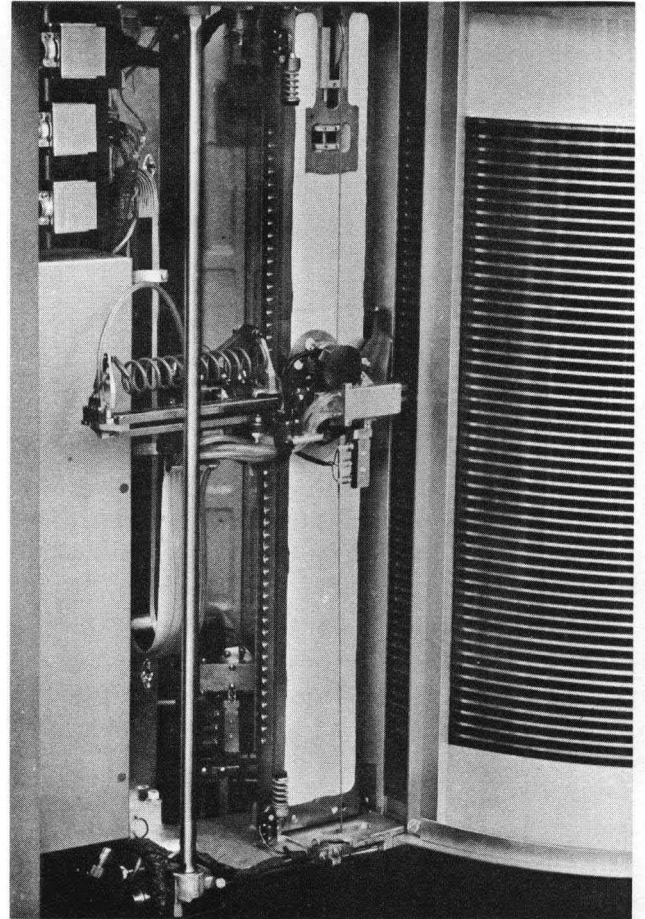

Figure 11. Access Arm

Processing

The manipulation that data undergoes in order to achieve desired results is called *processing*, and the part of the 1401 system that houses these operations is called the *processing unit*.

Logic

The logic function of any kind of data processing system is the ability to execute program steps; but even more, the ability to evaluate conditions and select alternative program steps on the basis of those conditions.

In unit-record equipment, an example of this logic is selector-controlled operations based on an X-punch or No X-punch, or based on a positive or negative value, or perhaps based on a comparison of control numbers in a given card field.

Similarly, the logic functions of the 1401 system control comparisons, branching (alternative decisions similar in concept to selector-controlled procedures), move and load operations (transfer of data or instructions), and the general ability to perform a complicated set of program steps with necessary variations.

Arithmetic

The IBM 1401 Processing Unit can add, subtract, multiply, and divide. Multiplication and division can be accomplished in any 1401 system, by programmed subroutines. When the extent of the calculations might otherwise limit the operation, a special multiply-divide feature is available.

Editing

As the term implies, editing adds significance to output data by punctuating and inserting special characters and symbols. The IBM 1401 has a unique ability to perform this function, automatically, with simple program instructions.

Internal Checking

Advanced circuit design is built into the 1401 to assure accurate results. Self-checking within the machine consists of *parity*, *validity*, and *hole count*.

PARITY CHECKING

The IBM 1401 checks characters at various locations in the system for odd-bit configurations. The six-bit, binary-coded-decimal internal language used by the 1401 also has a check bit for odd-bit checking purposes, and a word mark. The check bit is added to all characters that would otherwise have an even number of bits.

Example: A character P has a binary-coded decimal equivalent of B 4 2 1. The check bit is added to give this character an odd number of bits (C B 4 2 1).

If the character has a word mark associated with it, the word mark is included in the test for odd-bit parity.

Example: If the character P has a word mark, the check bit is not added because the bit configuration is odd (WM B 4 2 1).

Whenever a parity error occurs, a console light turns on, indicating the place where the error occurred (see *Console*).

VALIDITY CHECKING

A bit configuration that does not comprise a valid 1401 character causes a validity error in the 1401. For example, an invalid character passes a parity check because it contains an odd number of bits but does not pass a validity check.

A validity check is performed on each character as it is read into the 1401 by the card reader. An invalid character can get into core storage, but the validity-check circuits detect it and cause the 1401 to stop. The validity light on the card reader turns on to indicate the error.

Four types of address validity checking are performed by the 1401 processing system. The operations, and when they are performed, follow:

1. *Checking for a core-storage address greater than the installed core-storage capacity.* The units position of an address on from 4 to 12 thousand positions of core storage are checked for the proper A-, B-bit configuration. This check is performed when the output of the B-register goes to the storage-address register.
2. *Effective address checking* is divided into three tests that occur whenever core storage is addressed. The three tests are:
 - a. Incorrect parity
 - b. Illegal address character
 - c. A check of the hundreds and units positions of

an address for various core-storage sizes. A 1400-position system is checked for addresses between 1400 and 4000. A 2000-position system is checked for addresses between 2000 and 4000. A 12000-position system is checked for addresses between 12000 and 16000. If any of these conditions are found, a validity check occurs and the system stops.

3. *Index checking* is performed during an indexing operation to check for modification to an address in excess of installed core-storage capacity.
4. *End-around check* is made at all times except for three special operations. The modification of the low-order position of core storage by -1 , except during a CLEAR operation, or the modification of the high-order position of core storage by $+1$, except during STORAGE SCAN and STORAGE PRINT OUT operations, causes invalid operation and a system stop.

HOLE-COUNT CHECK

Reliability is further assured in the 1401 system by the *hole-count* feature of the IBM 1402 Card Read-Punch. With this feature, the total number of holes read in each column of a card at the read-check station is compared with the total number of holes read from the same column of the same card as it passes the read station. Hole-count checking is also performed in the punch-feed side. A count of the total number of holes to be punched in each column of the card at the punch station is retained internally for one punch-feed cycle. Another column-by-column hole count is taken as this same card passes the punch-check station, and the two counts are compared.

If a hole-count error (unequal comparison) occurs in either the read or punch side, the system stops and indicates the unit involved. The operator can determine where the error occurred by setting the mode switch to STORAGE SCAN and pressing the start key. The scan stops at the storage address of the column in error.

Variable Word Length

Stored programming involves the concept of *words*. A 1401 word can be a single character, or a group of characters that represent a complete unit of information. Because IBM 1401 words are not limited to a specific number of storage positions, and because each position of core storage is addressable, each word occupies only that number of core-storage locations actually needed for an instruction or data field.

WORD MARKS

The use of the variable-length instruction and data format requires a method of determining the instruction and data-word length. This identification is provided by a word mark. Word marks are illustrated by underlining the characters with which they are associated.

The word mark serves several functions:

1. Indicates the beginning of an instruction.
2. Defines the size of a data word.
3. Signals the end of execution of an instruction.

The rules governing the use of word marks are:

1. Predetermined locations for word marks are assigned in planning the program. These predetermined word marks are normally expected to remain in these locations throughout the complete program. The word marks are set into storage locations by a loading routine.
2. Word marks are not moved with data during processing, except when a *load* instruction (see *Move and Load*) is used.
3. For an arithmetic operation, the *B-field* must have a defining word mark, and the *A-field* must have a word mark only when it is shorter than the B-field.
4. A load instruction moves the word mark and data from the A-field to the B-field, and clears any other word marks in the designated B-field, up to the length of the A-field.
5. When moving data from one location to another, only one of the fields need have a defining word mark, because the *move* instruction implies that both fields are the same length.
6. A word mark must be associated with the high-order character (operation code) of every instruction.
7. ~~A 4-character unconditional branch instruction (BXXX) is the only instruction that can be followed by a blank without a word mark; all other instructions must be followed by a word mark.~~
8. A word mark must be set in the storage position at the immediate right of the last character of the last instruction in the program.

Two operation codes are provided for setting and clearing word marks during program execution.

Stored Program Instructions

All machine functions are initiated by instructions from the 1401 stored program. Because the 1401 uses

Page 15 – Word Marks – Item 7, replace with:

7. The 4-character unconditional branch instruction, the 7-character set word mark, and clear storage and branch instructions are the only instructions that can be followed by a blank without a word mark. All other instructions must be followed by a word mark.

the variable-word-length concept, the length of an instruction can vary from one to eight characters, depending on the operation to be performed.

Instruction Format

<i>Op Code</i>	<i>A- or I-address</i>	<i>B-address</i>	<i>d-character</i>
<u>X</u>	XXX	XXX	X

Op Code. This is always a single character that defines the basic operation to be performed. A word mark is always associated with the operation code position of an instruction.

A-Address. This always consists of three characters. It can identify the units position of the A-field, or it can be used to select a special unit or feature (tape unit, disk storage unit, IBM 1419 Magnetic Character Reader, etc.).

I-Address. Instructions that can cause program branches use the I-address to specify the location of the next instruction to be executed if a branch occurs.

B-Address. This is a three-character storage address that identifies the B-field. It usually addresses the units position of the B-field, but in some operations (such as tape read and write) it specifies the high-order position of a record-storage area.

d-Character. The d-character is used to modify an operation code. It is a single alphabetic, numerical, or special character, positioned as the last character of an instruction.

Examples of the six combinations possible in variable-length instructions are shown in Figure 12.

Instruction Descriptions

Specific instructions have been described in a standard format:

Title: This is the description of the instruction.

Instruction Format: This is the format of the particular instruction described. The mnemonic operation code used in the IBM 1401 Symbolic Programming System (SPS) is shown and the mnemonic for IBM 1401 Autocoder (A) is given, if it is different from the SPS mnemonic.

Function: This is the function of the instruction.

Word Marks: This is the effect of word marks with regard to data fields.

Timing: This is the formula to be used in calculating the timing of the instruction. Key to abbreviations used in formulas is shown in Figure 240.

Notes: These are special notations or additional information that pertain to the operation.

Address Registers After Operation: The contents of the address registers are represented by the codes described in the *Chaining Instructions* section.

Example: A practical application of the instruction is described and shown as labels for Autocoder and SPS (Symbolic Programming System) languages. With the label is the actual machine address in parentheses. It is not necessary for the programmer to know the actual address of a label when writing the program. The processor program assigns the actual address during the program assembly.

Assembled Instruction: This is the actual machine language instruction that is assembled by the Symbolic Programming System or Autocoder processor programs from the symbolic entries shown in the example.

NUMBER OF POSITIONS	OPERATION	INSTRUCTION FORMAT			
1	READ A CARD	Op code <u>1</u>			
2	SELECT STACKER	Op code <u>K</u>	d-character 2		
4	BRANCH	Op code <u>B</u>	l-address 400		
5	BRANCH IF INDICATOR ON	Op code <u>B</u>	l-address 625	d-character /	
7	ADD	Op code <u>A</u>	A-address 072	B-address 423	
8	BRANCH IF CHARACTER EQUAL	Op code <u>B</u>	l-address 650	B-address 080	d-character 4

Figure 12. IBM 1401 Instruction Formats

Addressing

Instructions and data to be used for processing in the 1401 are kept in core storage. Each position in storage is addressable (Figure 13). A field is defined by an eighth bit (called a *word mark*) and can contain either an instruction or data.

A data field is defined by a word mark in the high-order position. The units or low-order position of a data field is specified in the A- or B-address of the instruction. The data field is read from right to left until a word mark in the high-order position is sensed.

An instruction is addressed by giving the high-order (operation code) position of the instruction. All operation codes must have a word mark. (This word mark is normally set by the loading routine when the instructions are loaded.) The machine reads an instruction

CODED ADDRESSES IN STORAGE		
ACTUAL ADDRESSES		3-CHARACTER ADDRESSES
000 to 999	No zone bits	000 to 999
1000 to 1099	A-bit, using 0-zone	±00 to ±99
1100 to 1199		/00 to /99
1200 to 1299		S00 to S99
1300 to 1399		T00 to T99
1400 to 1499		U00 to U99
1500 to 1599		V00 to V99
1600 to 1699		W00 to W99
1700 to 1799		X00 to X99
1800 to 1899		Y00 to Y99
1900 to 1999		Z00 to Z99
2000 to 2099		B-bit, using 11-zone
2100 to 2199	J00 to J99	
2200 to 2299	K00 to K99	
2300 to 2399	L00 to L99	
2400 to 2499	M00 to M99	
2500 to 2599	N00 to N99	
2600 to 2699	*O00 to O99	
2700 to 2799	P00 to P99	
2800 to 2899	Q00 to Q99	
2900 to 2999	R00 to R99	
3000 to 3099	?00 to ?99	
3100 to 3199	A-B-bit, using 12-zone	A00 to A99
3200 to 3299		B00 to B99
3300 to 3399		C00 to C99
3400 to 3499		D00 to D99
3500 to 3599		E00 to E99
3600 to 3699		F00 to F99
3700 to 3799		G00 to G99
3800 to 3899		H00 to H99
3900 to 3999		I00 to I99

* Letter O followed by Zero Zero

Figure 13. Core Storage Address Codes

from left to right until it senses the word mark associated with the next sequential instruction. The final instruction in the program must have a word mark set at the right of its low-order position.

Example: Instruction address 400 (Figure 14) contains the operation code for the following instruction:

Op Code	A-address	B-address
<u>A</u>	542	560

When this instruction is executed, the data in the A-field is added to the data in the B-field:

```

0025347
04601231
-----
04626578
    
```

The result is stored in the B-field.

Input-Output Storage Assignments

Three areas of storage are reserved for input and output data. Storage positions 001 through 080, are reserved for the information from the 80 columns of the card. The second area of storage, positions 101 through 180, is reserved for assembling data to be punched. Positions 000 and 100 should not be used. Data stored in position 000 before a card read operation is replaced by CAB bits at the end of the read operation. Data stored in position 100 before a punch

Instruction addressed by high-order position

STORAGE ADDRESS	400	401	402	403	404	405	406	407 (NSI)
INSTRUCTION	<u>A</u>	5	4	2	5	6	0	WM Op code

The word mark associated with the next sequential instruction (NSI) stops the reading of this instruction.

STORAGE ADDRESS	536	537	538	539	540	541	542	543
DATA	<u>0</u>	0	2	5	3	4	7	<u>8</u>

A-address
↓
A-field
↑

Word mark identifies high-order position of A-field.

STORAGE ADDRESS	553	554	555	556	557	558	559	560	561
DATA	<u>0</u>	4	6	0	1	2	3	1	<u>4</u>

B-address
↓
B-field
↑

Word mark identifies high-order position of B-field.

Figure 14. Data and Instruction Addressing

operation is replaced by C82 bits at the end of the punch operation. The third area of storage, positions 201 through 300 or 332, is reserved for assembling characters to be printed. Positions 81 through 99, and 181 through 200, are available for normal storage use. When the reserved areas are not being used as specified, they can be used for other storage operations (Figure 15).

Operation of IBM 1401 Registers

The IBM 1401 Data Processing System can operate on and process data to produce a desired result by executing a series of instructions at high speed. A series of instructions designed to solve a problem is known as a *program*. Because these instructions are retained in core storage, it is more properly called a stored program.

The processing unit must interpret an instruction and perform the function prescribed by the instruction. In order to do this, various types of devices that are capable of receiving information, storing it, and transferring it as directed by control circuits are used. These

devices are known as *registers*. The 1401 has seven registers, four are address registers and three are character registers (Figure 16).

Address Registers

There are three address registers in the IBM 1401 Processing Unit. One controls program sequence, and the other two control the transfer of data from one storage location to another.

I-Address Register. The I- (Instruction) address register always contains the storage location of the next instruction character to be used by the stored program. The number in this register is increased by one as the instruction is read from left to right.

A-Address Register. The A-address register normally contains the storage address of the data in the A-address portion of an instruction. Normally, as the instruction is executed, the number in this register is decreased by 1 after each storage cycle that involves the A-address.

APPLICATION																DATE															
01	02	03	04	05	06	07	08	09	10	11	12	13	14	15	16	01	02	03	04	05	06	07	08	09	10	11	12	13	14	15	16
100	101															180															199
200	201															280															299
300																380															399
400																480															499
500																580															599
600																680															699
700																780															799
800																880															899
900																980															999
1000	1005	1010	1015	1020	1025	1030	1035	1040	1045	1050	1055	1060	1065	1070	1075	1080	1085	1090	1095	1100	1105	1110	1115	1120	1125	1130	1135	1140	1145	1149	
1100																1150															1199
1200																1250															1299
1300																1350															1399
1400																1450															1499
1500																1550															1599
1600																1650															1699
1700																1750															1799
1800																1850															1899
1900	1905	1910	1915	1920	1925	1930	1935	1940	1945	1950	1955	1960	1965	1970	1975	1980	1985	1990	1995	2000	2005	2010	2015	2020	2025	2030	2035	2040	2045	2049	

Figure 15. Core Storage Layout Chart

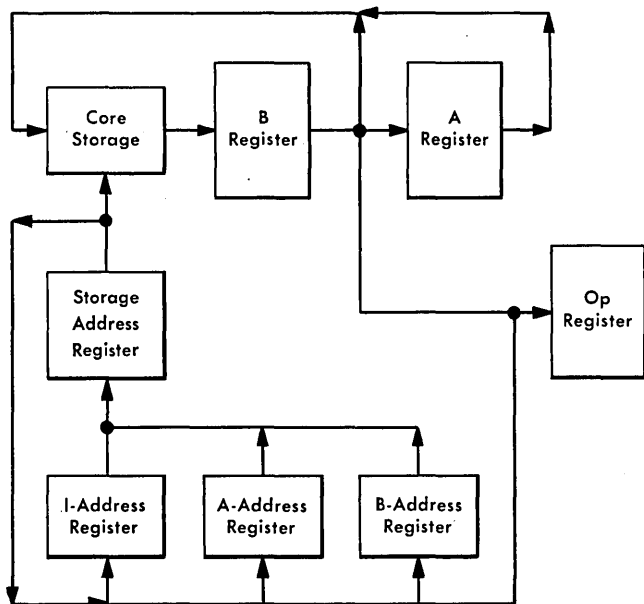

Figure 16. IBM 1401 Processing Unit Registers

Note: If the A-address portion of the instruction does not contain a 1401 storage address (for example %Ux) the contents of the A-address register are not disturbed as the instruction is executed.

B-Address Register. This register normally contains the storage location of the data in the B-address portion of an instruction. Normally, as a storage cycle involving the B-address is executed, the storage address in the B-address register is decreased by 1.

Character Registers

The A- and B-character registers and the Op-register are single-character registers used to store data during the execution of an instruction.

Op-Register. The Op- (Operation) register stores the operation code of the instruction in process for the duration of the operation. The operation code is stored in BCD code including the check bit, but excluding the word mark.

B-Register. Each character leaving 1401 core storage enters the B-register. The character is stored in 8-bit form (BCD code, check bit, and word mark). The B-register is reset and filled with a character from core storage on every storage cycle.

A-Register. The A-register is reset and filled with the character from the B-register during each storage cycle that involves the A-address, and during all

instruction cycles except the first and last I- (Instruction) cycle of each instruction. Data is stored in 8-bit form.

Note: Information can be written back into core storage directly from either the A- or B-register.

Figure 17 shows the I-phase of an operation and gives a detailed schematic for loading a 7-character instruction in the operation code register, in the A- and B-registers and in the I-, A-, and B-address registers. Eight storage cycles are required to load the complete instruction in the register. Each storage cycle requires .0115 millisecond.

Note: The A- and B-address registers contain 3-character addresses. Actual addresses are shown in this schematic because the storage display lights on the console show 4-digit addresses.

Chaining Instructions

In some programs, it becomes possible to perform a series of operations on several fields that are in consecutive storage locations. Some of the basic operations, such as ADD, SUBTRACT, MOVE, and LOAD, have the ability to be *chained* so that less time is required to perform the operations, and space is saved in storing instructions. Here is an example of the chaining technique: assume that four 5-position fields stored in sequence are to be added to four other sequential fields. This operation could be done using four 7-character instructions:

<u>A</u>	700	850
<u>A</u>	695	845
<u>A</u>	690	840
<u>A</u>	685	835

At the completion of the first instruction, the A-address register contains 695 and the B-address register contains 845. These are the same numbers that are in the A- and B-addresses in the second instruction. Eighty storage cycles would be required to execute these instructions, thus using up .920 millisecond. Also, 28 storage positions are required to store these instructions.

By taking advantage of the fact that the A- and B-address registers contain the necessary information to perform the next instruction, this same sequence of operations can be executed as follows:

<u>A</u>	700	850
<u>A</u>		
<u>A</u>		
<u>A</u>		

Connecting instructions together in this manner is called *chaining*. The first add instruction contains both

CYCLE	OPERATION	Instruction Location							
		A	5	6	7	T	1	2	S
		197	198	199	200	201	202	203	204
I-Op	The operation code enters the B-register and the Op-register. Because this is the first I-cycle, the A-register is undisturbed.	I Register 0 1 9 7		B Register A		A Register ?		Cycle 1	
		OP Register A		A Address Register ? ? ? ?		B Address Register ? ? ? ?			
I-1	The A-address register is reset to blanks during the first part of the cycle for all instructions. The B-address register is reset to blanks during the first part of the cycle for all operations except Move, Load, Store A- and Store B-address Register operation. During the I-1 cycle, the second instruction character (first character of the A-address) enters the thousands and hundreds positions of the A- and B-address registers and the A-register by the way of the B-register.	I Register 0 1 9 8		B Register 5		A Register 5		Cycle 2	
		OP Register A		A Address Register 0 5 b b		B Address Register 0 5 b b			
I-2	The third character of the instruction enters the tens position of the A- and B-address registers, and the A-register through the B-register.	I Register 0 1 9 9		B Register 6		A Register 6		Cycle 3	
		OP Register A		A Address Register 0 5 6 b		B Address Register 0 5 6 b			
I-3	The fourth instruction character enters the units position of the A- and B-address registers, and the A-register through the B-register.	I Register 0 2 0 0		B Register 7		A Register 7		Cycle 4	
		OP Register A		A Address Register 0 5 6 7		B Address Register 0 5 6 7			
I-4	The B-address register is reset at the beginning of this cycle. The fifth instruction character (first character of the B-address) enters the hundreds position of the B-address register, and the A-register through the B-register.	I Register 0 2 0 1		B Register T		A Register T		Cycle 5	
		OP Register A		A Address Register 0 5 6 7		B Address Register 1 3 b b			
I-5	The sixth instruction character goes to the tens position of the B-address register, and the A-register through the B-register.	I Register 0 2 0 2		B Register 1		A Register 1		Cycle 6	
		OP Register A		A Address Register 0 5 6 7		B Address Register 1 3 1 b			
I-6	The seventh character of the instruction (last character of the B-address) enters the units position of the B-address register and the A-register through the B-register.	I Register 0 2 0 3		B Register 2		A Register 2		Cycle 7	
		OP Register A		A Address Register 0 5 6 7		B Address Register 1 3 1 2			
I-7	The first character of the next instruction enters the B-register only. Because this is the last I-cycle for this instruction, the A-register and the Op-register, the A- and B-address registers are undisturbed. The detection of a word mark associated with this character signals the machine that this is the Op code for the next instruction. The loading operations stops, and the instruction that was just loaded is executed. Note that the I-address register contains the address of the high-order position of the next sequential instruction.	I Register 0 2 0 4		B Register S		A Register 2		Cycle 8	
		OP Register A		A Address Register 0 5 6 7		B Address Register 1 3 1 2			

Figure 17. Schematic of Instruction Loading

the A- and B-addresses. The following three instructions contain only the operation code for those instructions. The A- and B-addresses are the results left in the A- and B-address registers from the previous instruction. This type of operation requires 62 storage cycles, and takes .713 ms to execute. Storage of these chained instructions requires only ten storage positions.

The ability to chain a series of instructions does not depend on the use of the same operation code. Chained instructions may have various Op codes. To be operated on, the A-fields must be in sequence, and the B-fields must be in sequence. Example:

A 900 850
M
A
M

For example, assume that the data fields are each ten characters long:

- The ten characters at location 900 were added to 850.
- The ten characters at location 890 were moved to 840.
- The ten characters at location 880 were added to 830.
- The ten characters at location 870 were moved to 820.

The description of each instruction includes the contents of the address registers after the operation has been performed. Figure 18 shows the abbreviations that indicate the contents of these registers.

By using this information, the programmer can determine the status of the registers and decide whether chaining is practical in specific cases.

Note: Instructions that contain other than IBM 1401 storage addresses cannot be chained. For example, M %Ux xxx R is a tape read instruction. The tape unit is signaled as the machine reads the instruction. Although the A-address register contains %4x after the operation, chaining is impossible because the machine does not select the unit from the contents of the A-address register.

Most single-address instructions (Op code and an A-address) cause the A-address to be inserted in both the A- and B-address registers (for example A xxx). However, MOVE, LOAD, and STORE A- or STORE B-ADDRESS REGISTER (Op codes M, L, Q, and H) do not disturb the

B-address register, and therefore permit the programmer to use the previous contents of that register as part of the instruction.

All no-address instructions (Op code only) use the previous contents of the A- and B-address registers.

The contents of the B-address register after a branch instruction (Op code and I-address) depend on whether or not the indexing feature is installed in the 1401:

1. With the indexing feature installed, the B-address register contains the address of the next sequential instruction if a branch occurs.
2. Without the indexing feature installed, the B-address register is cleared to blanks whenever a branch occurs.

ABBREVIATION	MEANING
A	A-address of the instruction
B	B-address of the instruction
NSI	Address of the next sequential instruction
BI	Address of the next instruction if a branch occurs
L _A	The number of characters in the A-field
L _B	The number of characters in the B-field
L _D	The number of characters in a disk record
L _W	The number of characters in the A- or B-field, whichever is smaller
A _p	The previous setting of the A-address register
B _p	The previous setting of the B-address register
d _{pp}	The d-character and the tens and units positions of the previous register setting
d _{bi}	The d-character and the tens and units positions of the branch instruction
d _{bb}	The d-character and blank in the units and tens position

Figure 18. Contents of Address-Register Codes

IBM 1401 Programming Systems

The 1401 Symbolic Programming System and 1401 *Autocoder* are the basic symbolic programming aids for IBM 1401 Data Processing Systems. Each consists of a set of language specifications and a processor program. The language is used to write the source program, and the processor program translates the symbolic language program (the *source* program) into the actual machine language program (*object* program).

Symbolic Languages

Both the *Autocoder* and SPS languages permit the programmer to define areas, write instructions, and exercise some control over the execution of the processor program by writing symbolic statements. These statements are written using mnemonic operation codes (Figures 19 and 20) and the symbolic names with which the programmer names data, instructions, and work areas. For example, a symbolic instruction to add the data in a field called WHTAX to the data in a field called TOTDED would be written A WHTAX TOTDED in symbolic language.

Area Definition (Declarative Operations)

The area-definition entries are used to assign sections of storage for fixed data (constants) that will be needed during processing, to set aside work areas, and to assign symbolic names to data and devices used in the program. Area-definition statements are examined by the processor program during assembly of the object program. Some produce *constants* (cards that are loaded with the object program), but none produce instructions to be executed in the object program.

Instructions (Imperative Operations)

The instruction entries state symbolically the procedure to be taken during execution of the object program. They are actual commands to the object machine such as ADD, SUBTRACT, READ, PUNCH, etc.

Processor Control Operations

These are special instructions given by the programmer to the processor program. They exercise such control as: where to begin assigning storage for the object program, where the program ends, how much storage is available in the object-machine, etc. Processor control statements are never executed as instructions in the object program. They are used only during object-program assembly.

IBM 1401 Symbolic Programming System (SPS)

The SPS system is essentially a one-for-one coding system in which one symbolic statement is written for each instruction that appears in the object program. Two versions of the SPS are available. SPS-1 operates on a 1401 with 1400 positions of core storage, an IBM 1402 Card Read-Punch, and an IBM 1403 Printer, but it can assemble programs for any object-machine with as many as 4,000 positions of core-storage. SPS-2 can assemble programs for any 1401 system (1400 to 16,000 positions of core storage), but must assemble the program in a 1401 system with at least 4,000 positions of core-storage, the IBM 1402 Card Read-Punch, and an IBM 1403 Printer.

An SPS source program must be coded on the 1401 Symbolic Programming System Coding Sheet (form X24-1152). This coding sheet is designed for fixed-form coding. (A special area is reserved for each item to be contained in an SPS statement.)

A complete description of the 1401 SPS is contained in the IBM 1401 Data Processing System Bulletin, *IBM 1401 Symbolic Programming System, Preliminary Specifications* (form J24-0200).

A sample SPS program is shown in Figure 21.

IBM 1401 Autocoder

The 1401 *Autocoder* is a more powerful symbolic programming system for the IBM 1401 Data Processing System. This system provides a macro facility that permits the user to call out standard sets of instructions (routines) from a library stored on magnetic tape. It also permits him to code *literals* (actual data to be operated on during processing) directly in the instructions that use them, thus simplifying the area-definition part of the source program.

The 1401 *Autocoder* system can be used to assemble programs for all IBM 1401 Data Processing Systems. However, the machine used to assemble an *Autocoder* program must have at least:

- 4,000 positions of core storage
- Four IBM 729 II, 729 IV, 729 V, or 7330
Magnetic Tape Units
- IBM 1403 Printer, Model 2
- IBM 1402 Card Read-Punch
- Advanced-Programming Features
- High-Low-Equal Compare Feature
- Sense Switches

An *Autocoder* source program, like SPS, is written on a special coding sheet (form X24-1350). *Autocoder* statements, however, are written in free-form. (The operand fields are not divided into special areas as

AREA DEFINITION			
	Mnemonic Operation Code	Description	
	DCW DC DS DSA	Define Constant With Word Mark Define Constant (No Word Mark) Define Symbol Define Symbol Address	
INSTRUCTIONS			
Type	Mnemonic Operation Code	Description	Machine Language Equivalent
Arithmetic	A S *M *D ZA ZS	Add Subtract Multiply Divide Zero and Add Zero and Subtract	A S @ % ? (Prints as &) I (Prints as -)
Data Control	MCW *MCM MCS MN MZ MCE LCA SW CW CS *MIZ *MA *SAR *SBR	Move Characters to A or B Word Mark Move Characters to Record or Group Mark Move Characters and Suppress Zeros Move Numeric Move Zone Move Characters and Edit Load Characters to A Word Mark Set Word Mark Clear Word Mark Clear Storage Move and Insert Zeros (for reading 7070 Compressed Tape) Modify Address Store A Address Register Store B Address Register	M P Z D Y E L . □ / X # Q H
Logic Control	B BWZ C NOP H *BBE	Branch Branch if Word Mark and/or Zone Compare No Operation Halt Branch if Bit Equal	B V C N . W
System Control	R W WR P RP WP WRP *SRF *SPF SS CC CU MU LU	Read a Card Write a Line Write and Read Punch a Line Read and Punch Write and Punch Write, Read and Punch Start Read Feed Start Punch Feed Select Stacker Control Carriage Control Unit Move Unit Load Unit	1 2 3 4 5 6 7 8 9 K F U M L
PROCESSOR CONTROL OPERATIONS			
	Mnemonic Operation Code	Description	
	CTL ORG END EX	Control Origin End Execute	

*Pertains to an optional feature.

Figure 19. IBM 1401 Symbolic Programming System Mnemonics

DECLARATIVE OPERATIONS									
Mnemonic Op Code		Description			Type	Mnemonic Op Code	Description	Machine Op Code	Language d-char.
DA	Define Area				I/O Commands	†BSP	Backspace Tape	U	B
DC	Define Constant (No Word Mark)					†CU	Control Unit	U	d
DCW	Define Constant With Word Mark					DCR	Disengage Character Reader	U	D
DS	Define Symbol					ECR	Engage Character Reader	U	E
DSA	Define Symbol Address					†LU	Load Unit	L	d
EQU	Equate					†MU	Move Unit	M	d
						P	Punch	4	
						PCB	Punch Column Binary	4	C
						R	Read	1	
						RCB	Read Column Binary	1	C
					RD	Read Disk Single Record	M	R	
					RDT	Read Disk Full Track	M	R	
					RDW	Read Disk Single Record With Word Marks	L	R	
					RDTW	Read Disk Full Track With Word Marks	L	R	
					RF	Read Punch Feed	4	R	
					RP	Read and Punch	5		
					RT	Read Tape	M	R	
					RTB	Read Tape Binary	M	R	
					RTW	Read Tape With Word Marks	L	R	
					RWD	Rewind Tape	U	R	
					RWU	Rewind and Unload Tape	U	U	
					SD	Seek Disk	M	R	
					SKP	Skip and Blank Tape	U	E	
					SPF	Start Punch Feed	9		
					SRF	Start Read Feed	8		
					W	Write	2		
					WD	Write Disk Single Record	M	W	
					WDC	Write Disk Check	M	W	
					WDCW	Write Disk Check With Word Marks	L	W	
					WDT	Write Disk Full Track	M	W	
					WDTW	Write Disk Full Track With Word Marks	L	W	
					WDW	Write Disk Single Record With Word Marks	L	W	
					WM	Write Word Marks	2	□	
					WP	Write and Punch	6		
					WR	Write and Read	3		
					WRF	Write and Read Punch Feed	5	R	
					WRP	Write, Read and Punch	7		
					WT	Write Tape	M	W	
					WTB	Write Tape Binary	M	W	
					WTM	Write Tape Mark	U	M	
					WTW	Write Tape With Word Marks	L	W	
					†CC	Carriage Control	F	d	
					†CCB	Carriage Control and Branch	F	d	
					CS	Clear Storage	/		
					CW	Clear Word Mark	□		
					H	Halt	*		
					MA	Modify Address	#		
					NOP	No Operation	N		
					SAR	Store A-Address Register	Q		
					SBR	Store B-Address Register	H		
					†SS	Select Stacker	K	1, 2, 4, 8	
					†SSB	Select Stacker and Branch	K	1, 2, 4, 8	
					SW	Set Word Mark	/		
CONTROL OPERATIONS									
					Mnemonic	Description	Mnemonic	Description	
					CTL	Control	XFR	Transfer	
					END	End	SFX	Suffix	
					ENT	Enter New Coding Mode	JOB	Job	
					EX	Execute	INSER	Insert	
					LTORG	Literal Origin	ALTER	Alter	
					ORG	Origin	DELET	Delete	

†d-Character must be placed in operand when coding in Autocoder.

Figure 20. IBM 1401 Autocoder Mnemonics

IBM

1401 Symbolic Programming System
Coding Sheet

Program _____

Page No. 1 of 2

Programmed by _____

Date _____

Identification 76 80

LINE	COUNT	LABEL	OPERATION	(A) OPERAND				(B) OPERAND				d	COMMENTS
				ADDRESS	±	CHAR. ADJ.	IND.	ADDRESS	±	CHAR. ADJ.	IND.		
010			ORG	0500									
020	4	BEGIN	SW	0001									
030	1	START	R										
040	8		BWZ	PRINT			0001			K		PRINT IF X-COL 1	
050	7	PUNCH	MCW	0080			0180					MV CARD TO PUNCH	
060	4		P	START								PUNCH-BR TO START	
070	7	PRINT	MCW	0080			0280					MV CARD TO PRINT	
080	4		W	START								PRINT-BR TO START	
090			END	BEGIN									
100													

Page	Line No.	Count	Label	Op Code	(A) Operand	(B) Operand	d-Char.	Assigned Storage Locations	Assembled Machine-Language Instructions	Comments
1	010			ORG	0500					
1	020	4	Begin	SW	0001			0500	, 001	
1	030	1	Start	R				0504	1	
1	040	8		BWZ	Print	0001	K	0505	V 524 001 K	Print if X-Col 1
1	050	7	Punch	MCW	0080	0180		0513	M 080 180	MV Card to Pch
1	060	4		P	Start			0520	4 504	Pch-Br to St.
1	070	7	Print	MCW	0080	0280		0524	M 080 280	MV Card to Prt
1	080	4		W	Start			0531	2 504	Prnt-Br to St.
1	090			End	Begin				/ 504 080	

Figure 21. IBM 1401 Program in Symbolic Programming System Language

IBM

Program _____

INTERNATIONAL BUSINESS MACHINES CORPORATION

Programmed by _____

IBM 1401 AND 1410 DATA PROCESSING SYSTEMS
AUTOCODER CODING SHEET

Identification 76 80

Date _____

Page No. 1 of 2

Line	Label	Operation	OPERAND							
01		ORG	500							
02	BEGIN	SW	1							
03	START	R								
04		BWZ	PRINT, 1, K			PRINT IF X-COL 1				
05	PUNCH	MLC	80, 180			MOVE CARD TO PUNCH				
06		P	START			PUNCH AND BRANCH TO START				
07	PRINT	MLC	80, 280			MOVE CARD TO PRINT				
08		W	START			PRINT AND BRANCH TO START				
09		END	BEGIN							
10										

SEQ	PG	LIN	LABEL	OP	OPERANDS	SFX	CT	LOCN	INSTRUCT.	TYPE	CARD
001	1	010		ORG	500						
002	1	020	BEGIN	SW	1		4	0500	, 001		
003	1	030	START	R			1	0504	1		1
004	1	040		BWZ	PRINT, 1, K	Print if X-col	8	0505	V 524001K		1
005	1	050	PUNCH	MLC	80, 180	Move Card to Punch	7	0513	M 080 180		1
006	1	060		P	START	Punch and Branch to Start	4	0521	4 504		1
007	1	070	PRINT	MLC	80, 280	Move Card to Print	7	0524	M 080 280		1
008	1	080		W	START	Print and Br. to Start	4	0531	2 504		1
009	1	090		END	BEGIN				1 504 080		2

Figure 22. IBM 1401 Program in Autocoder

they are in SPS.) A complete description of 1401 *Autocoder* is contained in the IBM 1401 Data Processing System bulletin, *Autocoder for the IBM 1401: Preliminary Specifications* (form J24-1434).

Figure 22 shows the same program shown in Figure 21 coded in *Autocoder* language.

Input-Output Control System (IOCS)

The IBM 1401 input-output control system eliminates the need for detailed programming of standard input and output operations. It is included as part of the 1401 *Autocoder* system, and provides additional control, record-definition statements, and macro-instructions. With these entries the user can specify the input and output devices and the contents of file records. The library routines for reading and writing, blocking and deblocking, file labeling, and error checking are furnished as part of the *Autocoder* processor and can be extracted by using the IOCS macro-instructions.

The *Autocoder* processor tailors the IOCS routines to fit the particular requirements, specified by the programmer, for each job. The *Autocoder* processor produces the minimum number of instructions needed by interpreting the detailed information the programmer supplies in the control entries.

Although IOCS is used primarily for magnetic-tape files, IOCS macro-instructions can also be used for unit-record files (input and output files) from, and to, the IBM 1402 Card Read-Punch and the IBM 1403 Printer.

The IOCS is described in detail in the IBM 1401 Data Processing System bulletin: *Input-Output Control System* (form J24-1462).

IBM 1401 Report Program Generator (RPG)

The report program generator is a special program designed to produce report-writing object programs from report specifications given by the user.

Instead of writing a specific program for a report, the user states his problem in RPG language. The RPG processor program interprets these specifications and produces an object program that uses source data from punched-card, magnetic-tape, or disk-storage files. Output from the RPG-produced programs can be printed reports, punched cards, or magnetic tape.

The reports produced by programs generated by the RPG range from a simple listing of items from the input file to complex reports that incorporate editing and calculating the input data. Included are such functions as printing various kinds of lines (heading lines, detail lines, total lines initiated by control-field changes, offset total lines, etc.); serial and page numbering; crossfooting; and summary punching. Exception records can be produced with the reports.

The RPG processor can assemble object programs on a 1401 system with at least 4,000 positions of core-storage, an IBM 1402 Card Read-Punch, and an IBM 1403 Printer, Model 1 or 2. The machine requirements for executing the object program depend upon the units the user has specified.

The RPG is described in detail in the IBM 1401 Data Processing System bulletins: *Report Program Generator for IBM 1401 Card and Tape Systems* (form J24-0215) and *Report Program Generator for IBM RAMAC 1401 Systems* (form J24-1467).

Operation Codes

Arithmetic Operations

The IBM 1401 Data Processing System adds, subtracts, multiplies, and divides by applying the *add to storage* method of operation. The two factors to be combined are added within core storage without the use of special accumulators or counters. Because any storage area can be used as an accumulator field, the capacity for performing arithmetic functions is not limited by standard-size accumulators or by a predetermined number of accumulators within the system. Also, programming steps can be saved because some arithmetic operations require that only one field be transferred. In arithmetic operations, the 1401 system considers blanks and zeros the same. An unsigned field is considered positive by the system.

The design of the IBM 1401 Data Processing System provides for two types of add operations:

1. true add
2. complement add

The type of operation performed depends on the operation code and the algebraic signs of the factors. The resultant sign depends on the algebraic values of the factors (Figure 23).

A negative sign is indicated by a B-bit in the units position of a field. Any other zone-bit combination in the units position is considered a plus sign (A- and B-bits, A- no B-bit, or no A- no B-bit). Either A- and B-bits or no A- no B-bits should be used for signing a positive field.

A-field sign	+	-	+	-
B-field sign	+	-	-	+
Type of add	True	True	Comp	Comp
Sign of result	Sign B	Sign B	Sign of B-field unless A > B	

Figure 23. Algebraic Sign Control for Addition

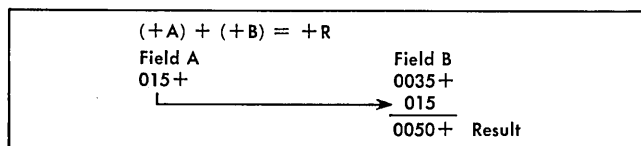

Figure 24. True Add

True Add

In a true add operation the result always carries the sign of the B-field (Figure 24).

Complement Add

If a complement add is initiated (see Figure 23) the machine converts the A-field to its tens complement figure and adds it to the B-field. The machine tests to determine whether a carry occurred from the high-order position of the B-field. The presence of a carry indicates that the result in the B-field is the true answer and the operation is terminated. The sign of the B-field is the sign of the result (Figure 25).

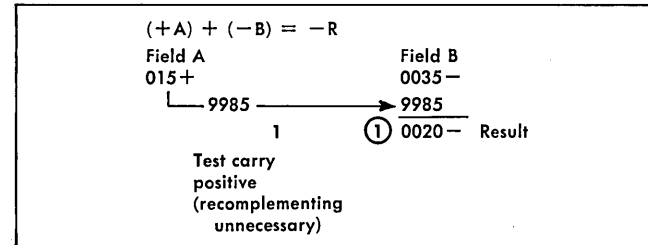

Figure 25. Complement Add with No Recomplementing

If there is no carry from the high-order position of the B-field, it indicates that the A-field was algebraically larger and that the result is not a true figure but is stored in its tens complement form. A recomplement cycle is performed automatically to convert the answer to true form.

To do this, the machine examines each digit in the B-field from high order to low order, until it detects a B-bit. The B-bit, located in the sign (low order) position of the field initiates the actual recomplement of the result. It changes the sign of the result and converts (from low order to high order) each digit to true form (Figure 26).

The sign of the B-field (result) is always in the form of A- and B-bits if it is plus, and a B-bit if it is minus.

Note: If the units position of a recomplemented field is located in the high-order storage position, a wrap-around addressing error occurs when this position is addressed on the reverse scan.

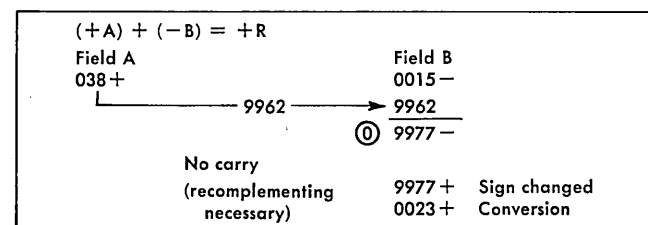

Figure 26. Complement Add with Recomplementing

Add

Instruction Format.

Mnemonic	Op Code	A-address	B-address
A	<u>A</u>	xxx	xxx

Function. The data in the A-field is added algebraically to the data in the B-field. The result is stored in the B-field.

Word Marks. The B-field must have a defining word mark, because it is this word mark that actually stops the add operation.

The A-field must have a word mark, only if it is shorter than the B-field. In this case, the transmission of data from the A-field stops after the A-field word mark is sensed. Zeros are then inserted in the A-register until the B-field word mark is sensed.

If the A-field is longer than the B-field, the high-order positions of the A-field that exceed the limits imposed by the B-field word mark are not processed. For overflow conditions and considerations, assume that the A-field is the same length as the B-field. (See *Address Modification without Index Feature*.)

Timing.

1. If the operation does not require a recomplement cycle:

$$T = .0115 (L_I + 3 + L_A + L_B) \text{ ms.}$$

2. If a recomplement cycle is taken:

$$T = .0115 (L_I + 3 + L_A + 4 L_B) \text{ ms.}$$

Note. Sign control: (see Figure 23).

If a recomplement cycle is automatically taken, the sign of the B (result)-field is changed and the result is always stored in true form.

If the fields to be added contain zone bits in other than the high-order position of the B-field and the sign positions of both fields, only the digits are used in a true-add operation. B-field zone bits are removed except for the units and high-order positions in a true-add operation. If a complement add takes place, zone bits are removed from all but the units positions of the B-field.

If an overflow occurs during a true-add operation, a special overflow indicator is set, and the overflow indications are stored over the high-order digit of the B-field:

Condition	Result
First overflow	A-bit
Second overflow	B-bit
Third overflow	A- and B-bits
Fourth overflow	No A- or B-bits

For subsequent overflows repeat conditions 1-4.

The BRANCH IF INDICATOR ON (B xxx Z) instruction tests and turns off the overflow indicator and branches to a special instruction or group of instructions if this condition occurs. There is only one overflow indicator in the system. It is turned off by a BRANCH IF INDICATOR ON instruction, or pressing the start reset key.

Address Registers After Operation.

I-Add. Reg.	A-Add. Reg.	B-Add. Reg.
NSI	A-L _w	B-L _B

Example. Add CURERN (0506) to YTDGRO (0708), Figure 27.

LINE	COUNT	LABEL	OPERATION	(A) OPERAND				(B) OPERAND				
				ADDRESS	±	CHAR. ADJ.	IND.	ADDRESS	±	CHAR. ADJ.	IND.	
3	0	7	A	0506				0708				
2	1	0										

Autocoder

Label	Operation	OPERAND			
A		05	30	35	45
		CURERN, YTDGRO			

Assembled Instruction: A 506 708

Figure 27. Add (Two-Address)

Add

Instruction Format.

Mnemonic	Op Code	A-address
A	<u>A</u>	xxx

Function. This format of the ADD instruction causes the data in the A-field to be added to itself.

Word Marks. The A-field must have a defining word mark. It is this word mark that stops the add operation. This instruction must be followed by a word mark in the position after the A-address.

Timing. $T = .0115 (L_I + 3 + 2 L_A) \text{ ms.}$

Address Registers After Operation.

I-Add. Reg.	A-Add. Reg.	B-Add. Reg.
NSI	A-L _A	A-L _A

Example. Add to itself the data at EXEMPT (0981), Figure 28.

Page 29 — Add instruction, add to last line of column one:

Overflow indication does not occur for a 1-position field.

SPS

LINE	COUNT	LABEL	OPERATION	(A) OPERAND				(B) OPERAND				d											
				ADDRESS	±	CHAR. ADJ.	IND.	ADDRESS	±	CHAR. ADJ.	IND.												
3	0	0	7	0																			
0	1	0																					

Autocoder

Label	Operation	OPERAND
A	EXEMPT	

Assembled Instruction: A 981

Figure 28. Add (Single-Address)

Zero and Add

Instruction Format.

Mnemonic	Op Code	A-address	B-address
ZA	?	xxx	xxx

Function. This instruction functionally adds the A-field to a zeroed B-field. Technically, this is accomplished by moving the A-field to the B-field. The high-order positions of the B-field are set to zero if the B-field is larger than the A-field. The data from the A-field moves directly from the A-register to storage. Zone bits are stripped from all positions except the units position. Blanks in the A-field are stored as blanks in the B-field.

Word Marks. A word mark is required for definition of the B-field. It is required in the A-field, only if it is shorter than the B-field. If the A-field is shorter than the B-field, all extra high-order B-field positions will contain zeros. But the transmission of data from A stops when the A-field word mark is detected.

Timing. $T = .0115 (L_I + 1 + L_A + L_B)$ ms.

Note: The sign of the result always has both A- and B-bits if it is positive. If the sign is negative, it has only a B-bit.

Address Registers After Operation.

I-Add. Reg.	A-Add. Reg.	B-Add. Reg.
NSI	A-L _w	B-L _B

Example. Zero WHTAX area (0796-0802) and add new TAX (0749-0754) to WHTAX (Figure 29).

SPS

LINE	COUNT	LABEL	OPERATION	(A) OPERAND				(B) OPERAND				d											
				ADDRESS	±	CHAR. ADJ.	IND.	ADDRESS	±	CHAR. ADJ.	IND.												
3	0	0	7	0																			
0	1	0																					

Autocoder

Label	Operation	OPERAND
ZA	TAX, WHTAX	

Assembled Instruction: ? 754 802

Figure 29. Reset Add

Subtract

Instruction Format.

Mnemonic	Op Code	A-address	B-address
S	<u>S</u>	xxx	xxx

Function. The numerical data in the A-field is subtracted algebraically from the numerical data in the B-field (Figure 30). The result is stored in the B-field.

A-field sign	+	-	+	-
B-field sign	+	-	-	+
Type of add	Comp	Comp	True	True
Sign of result	Sign of B-field unless A > B		Sign B	Sign B

Figure 30. Algebraic Sign Control for Subtraction

Word Marks. A word mark is required to define the B-field. An A-field requires a word mark, only if it is shorter than the B-field. In this case, the A-field word mark stops transmission of data from the A-field.

Timing.

- Subtract – no recomplement: $T = .0115 (L_I + 3 + L_A + L_B)$ ms.
- Subtract – recomplement cycle necessary: $T = .0115 (L_I + 3 + L_A + 4 L_B)$ ms.

Note. If a recomplement cycle is automatically taken, the sign of the B (result)-field is changed, and the result is always stored in true form.

Address Registers After Operation.

I-Add. Reg.	A-Add. Reg.	B-Add. Reg.
NSI	A-L _w	B-L _B

Example. Subtract CUFICA (0753) from CURGRO (0896), Figure 31.

SPS

LINE	COUNT	LABEL	OPERATION	(A) OPERAND				(B) OPERAND				d											
				ADDRESS	±	CHAR. ADJ.	IND.	ADDRESS	±	CHAR. ADJ.	IND.												
3	0	0	7	0																			
0	1	0																					

Autocoder

Label	Operation	OPERAND
S	CUFICA, CURGRO	

Assembled Instruction: S 753 896

Figure 31. Subtract (Two-Address)

Subtract

Instruction Format.

Mnemonic	Op Code	A-address
S	<u>S</u>	xxx

Function. The data at the A-address is subtracted from itself. If the A-field sign is minus, the result is a minus zero. If the A-field sign is plus, the result is a plus zero.

Word Marks. The A-field must have a defining word mark. This instruction must be followed by a word mark in the position after the A-address.

Timing. $T = .0115 (L_I + 3 + 2 L_A)$ ms.

Address Registers After Operation.

I-Add. Reg.	A-Add. Reg.	B-Add. Reg.
NSI	A-L _A	A-L _A

Example. Subtract from itself the field labeled LIMIT (units position is 0395), Figure 32.

LINE	COUNT	LABEL	OPERATION	(A) OPERAND				(B) OPERAND				d			
				ADDRESS	±	CHAR. ADJ.	REG.	ADDRESS	±	CHAR. ADJ.	REG.				
3	8	7	8	13	14	16	17	23	24	27	28	34	35	38	39
0	1	0		S		LIMIT									

Label	Operation	OPERAND
6	13	20
	S	LIMIT

Assembled Instruction: S 395

Figure 32. Subtract (Single-Address)

Zero and Subtract

Instruction Format.

Mnemonic	Op Code	A-address	B-address
ZS	<u>Z</u>	xxx	xxx

Function. This instruction functionally subtracts the A-field from a zeroed B-field. Technically, this is accomplished by moving the A-field to the B-field. The high-order positions of the B-field are set to zero if the B-field is larger than the A-field. The data from the A-field is moved directly from the A-register to the B-field. Zone bits are stripped from all but the sign (units) position.

Word Marks. A word mark is required to define the B-field. If the A-field is shorter than the B-field, the A-field must have a defining word mark to stop transmission of data to B. The extra high-order B-field positions contain zeros, if A is shorter than B.

Timing. $T = .0115 (L_I + 1 + L_A + L_B)$ ms.

Address Registers After Operation.

I-Add. Reg.	A-Add. Reg.	B-Add. Reg.
NSI	A-L _w	B-L _B

Example. Subtract TAXEXP (0699) from ACCUM1 (0755), Figure 33.

LINE	COUNT	LABEL	OPERATION	(A) OPERAND				(B) OPERAND				d			
				ADDRESS	±	CHAR. ADJ.	REG.	ADDRESS	±	CHAR. ADJ.	REG.				
3	8	7	8	13	14	16	17	23	24	27	28	34	35	38	39
0	1	0		S		TAXEXP									

Label	Operation	OPERAND
6	13	20
	S	TAXEXP, ACCUM1

Assembled Instruction: I 699 755

Figure 33. Reset Subtract (Two-Address)

Zero and Subtract

Instruction Format.

Mnemonic	Op Code	A-address
ZS	<u>Z</u>	xxx

Function. This instruction causes the sign of the A-field to be changed.

Word Marks. The data in the A-field requires a word mark in its high-order position.

Timing. $T = .0115 (L_I + 1 + 2 L_A)$ ms.

Address Registers After Operation.

I-Add. Reg.	A-Add. Reg.	B-Add. Reg.
NSI	A-L _A	A-L _A

Example. Subtract LIMIT (0495) from zero, and change sign of LIMIT's value (Figure 34).

LINE	COUNT	LABEL	OPERATION	(A) OPERAND				(B) OPERAND				d			
				ADDRESS	±	CHAR. ADJ.	REG.	ADDRESS	±	CHAR. ADJ.	REG.				
3	8	7	8	13	14	16	17	23	24	27	28	34	35	38	39
0	1	0		ZS		LIMIT									

Label	Operation	OPERAND
6	13	20
	ZS	LIMIT

Assembled Instruction: I 495

Figure 34. Reset Subtract (Single-Address)

Page 31 — Zero and Subtract instruction, add:

Note: If the A-field is positive, the B-field result is negative. If the A-field is negative, the B-field result is positive.

Logic Operations

The logic operation codes provide the decision-making ability of the IBM 1401 Data Processing System. They allow the program to test for conditions that can arise during processing, and to branch to predetermined sets of instructions, or subroutines as a result of a specific condition.

For example, if an overflow occurs in an arithmetic operation, a special routine to handle this condition can be initiated by a BRANCH IF INDICATOR ON instruction.

Note: Any operation that terminates with a successful branch to another portion of core storage for the next instruction address operates as follows:

1. Without Indexing—The B-address register is reset to blanks during the next instruction operation (I-Op) cycle.
2. With Indexing — A dummy cycle occurs before the next instruction operation (I-Op) cycle and the next sequential instruction (NSI), is transferred into the B-address register. One cycle must be added to the instruction time to account for the dummy cycle.

Branch

Instruction Format.

<i>Mnemonic</i> B	<i>Op Code</i> B	<i>I-address</i> xxx
----------------------	---------------------	-------------------------

Function. This instruction always causes the program to branch to the instruction specified by the I-address. It is used to interrupt normal program sequence and to continue the program at any desired point, without testing for specific conditions.

Word Marks. Word marks are not affected.

Timing. $T = .0115 (L_1 + 1)$ ms.

Address Registers After Operation.

<i>I-Add. Reg.</i> NSI	<i>A-Add. Reg.</i> BI	<i>B-Add. Reg.</i> BI
---------------------------	--------------------------	--------------------------

Example. Unconditionally branch to AGAIN (3498), Figure 35.

SPS			(A) OPERAND				(B) OPERAND				d	
LINE	COUNT	LABEL	OPERATION	ADDRESS	CHAR. ADDR.	ADDRESS	CHAR. ADDR.					
3	0	0	B	3498								

Autocoder			OPERAND			
Line	Label	Operation	28	30	38	40
6	B	AGAIN				

Assembled Instruction: B D98

Branch if Indicator On

Instruction Format.

<i>Mnemonic</i> SPS B A see chart	<i>Op Code</i> B	<i>I-address</i> xxx	<i>d-character</i> x
---	---------------------	-------------------------	-------------------------

Function. The d-character specifies the indicator tested. If the indicator is on, the next instruction is taken from the I-address. If the indicator is off, the next sequential instruction is taken. Figure 36 shows characters that are valid for the d-character and for the indicators they test. This figure also shows testing, for high, low, or equal, which is used when the high-low-equal compare special feature is installed.

The indicators tested are not turned off by this instruction except as noted by a †. When carriage tape-channels 9 or 12 are sensed, corresponding indicators are turned on. These carriage channel-indicators are turned off when any other carriage tape-channel is sensed. The next COMPARE instruction turns off the compare indicators.

Word Marks. Word marks are not affected.

Timing. $T = .0115 (L_1 + 1)$ ms.

AUTOCODER MNEMONIC	d-CHARACTER	BRANCH ON
B	bl	Unconditional
BC9	9	Carriage Channel #9
BCV	@	Carriage Channel #12
BLC	A	"Last Card" switch (sense switch A)
BSS ‡	B	Sense Switch B*
BSS ‡	C	Sense Switch C*
BSS ‡	D	Sense Switch D*
BSS ‡	E	Sense Switch E*
BSS ‡	F	Sense Switch F*
BSS ‡	G	Sense Switch G*
BEF	K	End of Reel*†
BER	L	Tape Transmission Error*
BIN ‡	N	Access Inoperable*
BIN ‡	?	Reader Error if I/O Check Stop Switch is off†
BIN ‡	I	Punch Error if I/O Check Stop Switch is off†
BPB	P	Printer Busy (print storage feature)*
BIN ‡	±	Printer Error if I/O Check Stop Switch is off†
BU	/	Unequal Compare (B ≠ A)
BIN ‡	*	Inquiry Clear*
BIN ‡	Q	Inquiry Request*
BPCB	R	Printer Carriage Busy (print storage feature)*
BE	S	Equal Compare (B = A)*
BL	T	Low Compare (B < A)*
BH	U	High Compare (B > A)*
BIN ‡	V	Read-Write Parity Check or Read-Back Check Error*
BIN ‡	W	Wrong-Length Record*
BIN ‡	X	Unequal-Address Compare*
BIN ‡	Y	Any Disk-Unit Error Condition*
BAV	Z	Overflow†
BIN ‡	%	Processing Check with Process Check Switch off†

*Special feature

†Conditions tested are reset by a BRANCH IF INDICATOR ON instruction.

‡The d-character must be used with this mnemonic.

Figure 35. Branch

Figure 36. d-Characters for Branch Instruction

Address Registers After Operation.

I-Add. Reg. A-Add. Reg. B-Add. Reg.
 NSI BI dbb

Example. Test for last card. If it is the last card, branch to END (0599), Figure 37.

LINE	COUNT	LABEL	OPERATION	(A) OPERAND						(B) OPERAND					
				ADDRESS	±	CHAR. ADJ.	±	CHAR. ADJ.	±	CHAR. ADJ.	±	CHAR. ADJ.	±	CHAR. ADJ.	
0	1		B	END											

Label	Operation	OPERAND
BLC	END	

Assembled Instruction: B 599 A

Figure 37. Test and Branch

Branch if Character Equal

Instruction Format.

Mnemonic	Op Code	I-address	B-address	d-character
SPS B	<u>B</u>	xxx	xxx	x
A BCE				

Function. This code causes the single character at the B-address to be compared to the d-character. If it has the same bit configuration as the d-character, the program branches to the I-address, otherwise the program continues sequentially. The d-character can be any combination of the six BCD code bits (BA 8421).

Word Marks. Word marks in the location tested have no effect on the operation.

Timing. T = .0115 (L_I + 2) ms.

Address Registers After Operation.

I-Add. Reg. A-Add. Reg. B-Add. Reg.
 NSI BI B-1

Example. This example shows how the chaining method can be used to test an entire field for blank characters. Each position in the area labeled AMOUNT (0350, 0349, 0348 and 0347) is individually tested for a blank character. If a blank is found, the program branches to BLANK (0601) for the next instruction. If the position tested contains a character, the program continues in sequence (Figure 38).

SPS

LINE	COUNT	LABEL	OPERATION	(A) OPERAND						(B) OPERAND					
				ADDRESS	±	CHAR. ADJ.	±	CHAR. ADJ.	±	CHAR. ADJ.	±	CHAR. ADJ.	±	CHAR. ADJ.	
0	1		B	BLANK						AMOUNT					
0	2		B												
0	3		B												
0	4		B												

Autocoder

Label	Operation	OPERAND
BCE	BLANK	AMOUNT
BCE		
BCE		
BCE		

Assembled Instruction: B 601 350 bl

B
B
B

Figure 38. Test Character and Branch

Branch if Word Mark and/or Zone

Instruction Format.

Mnemonic	Op Code	I-address	B-address	d-character
BWZ	<u>V</u>	xxx	xxx	x

Function. The single character at the B-address is examined for a particular bit configuration, as specified by the d-character. If the bit configuration is present as specified, the program branches to the I-address for the next instruction:

d-character	Condition
1	Word mark
2	No zone (No-A, No-B-bit)
B	12-zone (AB-bits)
K	11-zone (B, No-A-bit)
S	Zero-zone (A, No-B-bit)
3	Either a word mark, or no zone
C	Either a word mark, or 12-zone
L	Either a word mark, or 11-zone
T	Either a word mark, or zero-zone

Word Marks. These have been explained previously.

Timing. T = .0115 (L_I + 2) ms.

Address Registers After Operation.

I-Add. Reg. A-Add. Reg. B-Add. Reg.
 NSI BI B-1

Example. Test the units position of GROAMT (2498) for an 11-zone, and branch to NEGRTE (0598) for the next instruction. If there is no 11-zone, continue the program sequence (Figure 39).

Page 34 — No Operation instruction, add to Function:

Instructions that have A-addresses of %xx or @xx should have their A-address field, as well as the operation code position, changed to N's to perform a no operation function successfully.

SPS

LINE	COUNT	LABEL	OPERATION	(A) OPERAND				(B) OPERAND				d	
				ADDRESS	CHAR. ADJ.	IND.	...	ADDRESS	CHAR. ADJ.	IND.	...		
0	1	0											
0	2	0											
			C	DEPT.CD				DEPT.NO					
			B	TOTAL									

Autocoder

Label	Operation	OPERAND									
6	15	20	21	25	30	35	40	45	50		
	C	DEPT.CD, DEPT.NO									
	B	TOTAL									

Assembled Instruction: C 004 \neq 98
B 495 /

Figure 41. Compare

Halt

Instruction Format.

Mnemonic Op-Code
 H .

Function. This instruction causes the machine to stop and the stop-key light to turn on. Pressing the start key causes the program to start at the next instruction in sequence.

Word Marks. Word marks are not affected.

Timing. $T = .0115 (L_I + 1)$ ms.

Address Registers After Operation.

I-Add. Reg. A-Add. Reg. B-Add. Reg.
 NSI Ap Bp

Example. Figure 42 is a symbolic example of the HALT instruction.

SPS

LINE	COUNT	LABEL	OPERATION	(A) OPERAND				(B) OPERAND				d
				ADDRESS	CHAR. ADJ.	IND.	...	ADDRESS	CHAR. ADJ.	IND.	...	
0	1	0										
			H									

Autocoder

Label	Operation	OPERAND									
6	15	20	21	25	30	35	40	45	50		
	H										

Assembled Instruction: .

Figure 42. Halt

Halt and Branch

Instruction Format.

Mnemonic Op Code I-address
 H . xxx

Function. This is the same as HALT, except that the next instruction is at the I-address.

Word Marks. Word marks are not affected.

Timing. $T = .0115 (L_I + 1)$ ms.

Address Registers After Operation.

I-Add. Reg. A-Add. Reg. B-Add. Reg.
 NSI BI BI

Example. Stop the system, and branch to START2 (0895) for the next instruction when the start key is pressed (Figure 43).

SPS

LINE	COUNT	LABEL	OPERATION	(A) OPERAND				(B) OPERAND				d
				ADDRESS	CHAR. ADJ.	IND.	...	ADDRESS	CHAR. ADJ.	IND.	...	
0	1	0										
			H	START2								

Autocoder

Label	Operation	OPERAND									
6	15	20	21	25	30	35	40	45	50		
	H	START2									

Assembled Instruction: . 895

Figure 43. Halt and Branch

Clear, Move, Load, and Word Mark Operations

To organize specific storage areas for efficient processing, data must be processed, and word marks must be set in storage in the proper locations.

Because the IBM 1401 operates with variable length data and instructions, and because word marks control the definition of each, special attention must be given to the proper positioning of each word mark required. Extraneous word marks are just as damaging to program operation as the absence of a word mark when it is needed.

Before any program is loaded, all positions of storage should be cleared of data and word marks. Pressing the load key on the console causes a word mark to be set at location 001. The program itself should contain the instructions to set all other word marks needed for the operation.

Move and Load operations transfer data from one location to another. The Move operation does not affect word marks, but the Load operation causes word marks, as well as data, to be transferred.

Clear Storage

Instruction Format.

Mnemonic Op Code A-address
 CS / xxx

Function. As many as 100 positions of core storage can be cleared of data and word marks when this instruction is executed. Clearing starts at the A-address and continues leftward to the nearest hundreds position. The cleared area is set to blanks.

Word Marks. Word marks are not required to stop the operation.

Timing. $T = .0115 (L_I + 1 + L_N)$ ms.

Note: During the execution of this instruction, only the B-address register is used. Therefore, when chaining is being considered, the contents of the A-address register can be ignored.

Address Registers After Operation.

I-Add. Reg. A-Add. Reg. B-Add. Reg.
 NSI A x 00-1

Example. Clear WAREA5 (0500-0563), Figure 44.

LINE	COUNT	LABEL	OPERATION	(A) OPERAND				(B) OPERAND				d			
				ADDRESS	±	CHAR. ADJ.	±	ADDRESS	±	CHAR. ADJ.	±				
3	8	7	8	13	14	15	17	23	24	27	28	34	35	38	39
0	1	0		CS				WAREA5							

6	Label	Operation	OPERAND						
15	16	20	21	25	30	35	40	45	50
	CS	/							WAREA5

Assembled Instruction: / 563

Figure 44. Clear

Clear Storage and Branch

Instruction Format.

Mnemonic Op Code I-address B-address
 CS / xxx xxx

Function. This is the same as the CLEAR STORAGE instruction, except that the clearing starts at the B-address. The I-address specifies the location of the next instruction.

~~Word Marks. Word marks are not required to stop the operation.~~

Timing. $T = .0115 (L_I + 1 + L_N)$ ms.

Address Registers After Operation.

I-Add. Reg. A-Add. Reg. B-Add. Reg.
 NSI BI x 00-1

Example. Clear WAREA8 (0800-0898) and branch to START4 (0498) for the next instruction (Figure 45).

LINE	COUNT	LABEL	OPERATION	(A) OPERAND				(B) OPERAND				d			
				ADDRESS	±	CHAR. ADJ.	±	ADDRESS	±	CHAR. ADJ.	±				
3	8	7	8	13	14	15	17	23	24	27	28	34	35	38	39
0	1	0		CS				START4				WAREA8			

6	Label	Operation	OPERAND						
15	16	20	21	25	30	35	40	45	50
	CS	/							START4, WAREA8

Assembled Instruction: / 498 898

Figure 45. Clear and Branch

Set Word Mark

Instruction Format.

Mnemonic Op Code A-address B-address
 SW / xxx xxx

Function. A word mark is set at each address specified in the instruction. The data at each address is undisturbed.

~~Word Marks. Word marks are set at both the A- and B-addresses specified.~~

Timing. $T = .0115 (L_I + 3)$ ms.

Address Registers After Operation.

I-Add. Reg. A-Add. Reg. B-Add. Reg.
 NSI A-1 B-1

Example. Set word marks at locations BEGIN1 (3950) and BEGIN2 (3970), Figure 46.

LINE	COUNT	LABEL	OPERATION	(A) OPERAND				(B) OPERAND				d			
				ADDRESS	±	CHAR. ADJ.	±	ADDRESS	±	CHAR. ADJ.	±				
3	8	7	8	13	14	15	17	23	24	27	28	34	35	38	39
0	1	0		SW				BEGIN1				BEGIN2			

6	Label	Operation	OPERAND						
15	16	20	21	25	30	35	40	45	50
	SW	/							BEGIN1, BEGIN2

Assembled Instruction: / 150 170

Figure 46. Set Word Mark (Two-Address)

Set Word Mark

Instruction Format.

Mnemonic Op Code A-address
 SW / xxx

Function. This format of the SET WORD MARK instruction causes a word mark to be set at the A-address. Data at this address is undisturbed.

Page 36 — Clear Storage and Branch instruction, replace Word Marks with:

Word Marks. Word marks are not required to stop the operation. It is not necessary to follow this instruction by a character with a word mark.

Page 36 — Set Word Mark instruction (two addresses), replace Word Marks with:

Word Marks. Word marks are set at both the A- and B-addresses specified. It is not necessary to follow this instruction by a character with a word mark.

Word Marks. A word mark is set at the A-address.

Timing. $T = .0115 (L_1 + 3)$ ms.

Address Registers After Operation.

I-Add. Reg. A-Add. Reg. B-Add. Reg.
NSI A-1 A-1

Example. Set a word mark at AREA2 (2901), Figure 47.

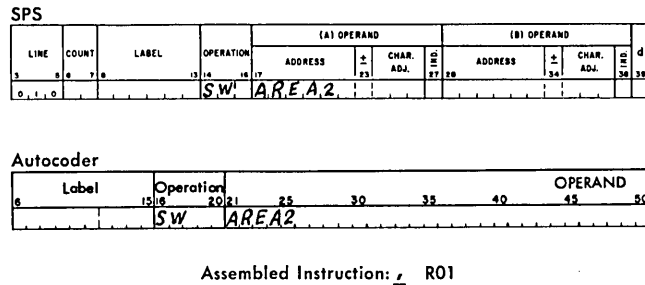

Figure 47. Set Word Mark (Single-Address)

Clear Word Mark

Instruction Format.

Mnemonic Op Code A-address B-address
CW \square xxx xxx

Function. This instruction clears word marks at the locations specified by the A- and B-addresses, without disturbing the data there.

Word Marks. Word marks are cleared at the A- and B-addresses.

Timing. $T = .0115 (L_1 + 3)$ ms.

Address Registers After Operation.

I-Add. Reg. A-Add. Reg. B-Add. Reg.
NSI A-1 B-1

Example. Clear the word marks at NETPAY (1924) and ACCUM4 (3309), Figure 48.

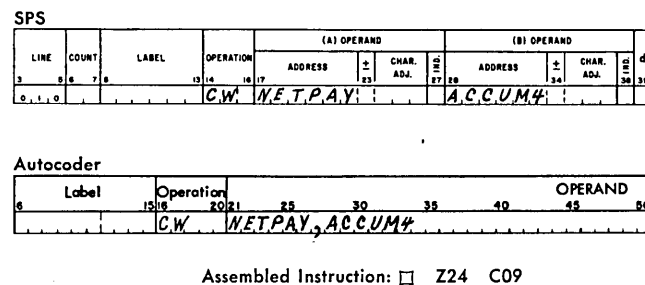

Figure 48. Clear Word Mark (Two-Address)

Clear Word Mark

Instruction Format.

Mnemonic Op Code A-address
CW \square xxx

Function. This format of the CLEAR WORD MARK instruction causes the word mark to be cleared at the A-address. Data at the A-address is not disturbed.

Word Marks. Word marks are cleared at the A-address only.

Timing. $T = .0115 (L_1 + 3)$ ms.

Address Registers After Operation.

I-Add. Reg. A-Add. Reg. B-Add. Reg.
NSI A-1 A-1

Example. Clear the word mark at RECNO1 (3608), Figure 49.

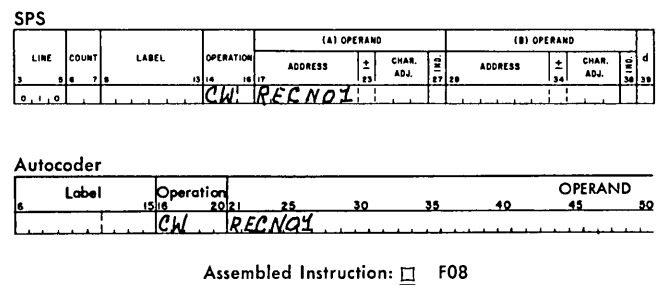

Figure 49. Clear Word Mark (Single-Address)

Move Characters to A or B Word Mark

Instruction Format.

Mnemonic Op Code A-address B-address
SPS MCW $\underline{\quad}$ xxx xxx
A MLC

Function. The data in the A-field is moved to the B-field.

Word Marks. If both fields are the same length, only one of the fields must have a defining word mark. The first word mark encountered stops the operation. If the word mark is sensed in the A-field, the machine takes one more B-cycle to move the high-order character from A to B. At the end of the operation, the A-address register and the B-address register contain the addresses of the storage locations immediately to the left of the A- and B-fields processed by the instruction. The data at the A-address is unaffected by the move operation. Word marks in both fields are undisturbed.

Timing. $T = .0115 (L_1 + 1 + 2 L_W)$ ms.

Note. If the fields are unequal in length, chaining can produce unwanted results, because one of the fields has not been completely processed. Thus, one of the registers will *not* contain the address of the units position of the left-adjacent field.

Address Registers After Operation.

I-Add. Reg.	A-Add. Reg.	B-Add. Reg.
NSI	A-L _w	B-L _w

Example. Move the 5-character field NAMED (0750) to the 5-character field NAMEOUT (0850), Figure 50.

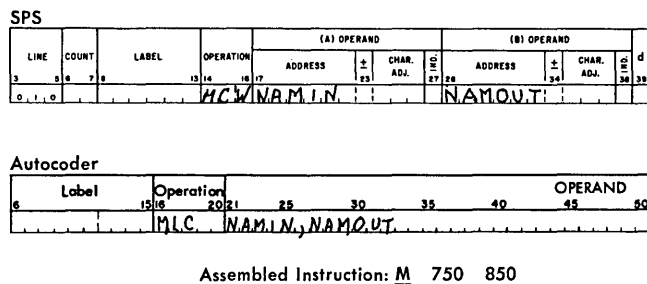

Figure 50. Move (Two-Address)

Move Characters to A or B Word Mark

Instruction Format.

Mnemonic	Op Code	A-address
SPS MCW	<u>M</u>	xxx
A MLC		

Function. This format of the move operation can be used when it is desired to move fields from the A-area and store them sequentially in the B-area. It saves program storage space and time, because the B-address is automatically taken from the B-address register, and does not have to be written or interpreted as part of the instruction.

Word Marks. A word mark is required over the high-order position of the A- or B-field. The first word mark encountered stops the move operation.

Timing. T = .0115 (L_I + 1 + 2 L_w) ms.

Address Registers After Operation.

I-Add. Reg.	A-Add. Reg.	B-Add. Reg.
NSI	A-L _w	Bp-L _w

Example. Move the following three fields (labeled EMPNO, DEPTNO and TAXCLS) and store them

sequentially at RECOUT (units position at 0204), Figure 51.

Note: If the B-address register already contains the correct address, the B-label of the first instruction in the example can be eliminated.

	A-label	A-actual address	B-label	B-actual address
Employee number	EMPYNO	0101-0104		0201-0204
Department	DEPTNO	0108-0110		0205-0207
Tax Class	TAXCLS	0114-0115	RECOUT	0208-0209

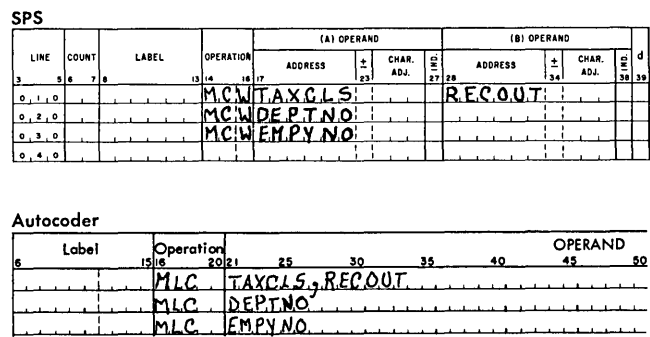

Figure 51. Move (Single-Address)

Move Characters and Suppress Zeros

Instruction Format.

Mnemonic	Op Code	A-address	B-address
MCS	<u>Z</u>	xxx	xxx

Function. The data in the A-field is moved to the B-field. After the move, high-order zeros and commas are replaced by blanks in the B-field. Any character that is not a comma, hyphen, blank, significant digit, or zero causes zero suppression to begin again. The sign is removed from the units position of the data field.

Word Marks. The A-field word mark stops transmission of data. B-field word marks, encountered during the move operation, are erased.

Timing. T = .0115 (L_I + 1 + 3 L_A) ms.

Address Registers After Operation.

I-Add. Reg.	A-Add. Reg.	B-Add. Reg.
NSI	A-L _A	B + 1

Example. Move and suppress the zeros in the 10-character field labeled INVBAL (0958) to the area labeled OUTPT4 (0448), Figure 52.

Page 38 — Move Characters and Suppress Zeros instruction, add:

Note: This description of the instruction assumes a 1401 system without the expanded print edit feature. If expanded print edit is installed, a decimal does not cause zero suppression to begin again.

SPS															
LINE	COUNT	LABEL	OPERATION	(A) OPERAND				(B) OPERAND							
				ADDRESS	±	CHAR. ADJ.	±	ADDRESS	±	CHAR. ADJ.	±				
3	8	7	9	13	14	16	17	23	24	27	28	34	35	38	39
0	1	0		MCS				INVBAL				OUTPT#			

Autocoder										
Label	Operation	OPERAND								
6	15	16	20	21	25	30	35	40	45	50
		MCS			INVBAL				OUTPT#	

Assembled Instruction: Z 958 448

Figure 52. Move and Zero Suppress

Move Numerical

Instruction Format.

Mnemonic	Op Code	A-address	B-address
SPS MN	<u>D</u>	xxx	xxx
A MLNS			

Function. The numerical portion (8-4-2-1 bits) of the single character in the A-address is moved to the B-address. The zone portions (AB-bits) are undisturbed at both addresses.

Word Marks. Word marks are not required at either address, because the nature of the instruction always specifies that only one digit is to be transmitted.

Timing. $T = .0115 (L_1 + 3)$ ms.

Address Registers After Operation.

I-Add. Reg.	A-Add. Reg.	B-Add. Reg.
NSI	A-1	B-1

Example. Move the numerical portion of the units position of ONHAND (0986) to OUT5 (0789), Figure 53.

SPS															
LINE	COUNT	LABEL	OPERATION	(A) OPERAND				(B) OPERAND							
				ADDRESS	±	CHAR. ADJ.	±	ADDRESS	±	CHAR. ADJ.	±				
3	8	7	9	13	14	16	17	23	24	27	28	34	35	38	39
0	1	0		MN				ONHAND				OUT5			

Autocoder										
Label	Operation	OPERAND								
6	15	16	20	21	25	30	35	40	45	50
		MLNS			ONHAND				OUT5	

Assembled Instruction: D 986 789

Figure 53. Move Digit

Move Zone

Instruction Format.

Mnemonic	Op Code	A-address	B-address
SPS MZ	<u>Y</u>	xxx	xxx
A MLZS			

Function. Only the zone portion (AB-bits) is moved from the A-address to the B-address. The digit portions (8-4-2-1 bits) are undisturbed at both addresses.

Word Marks. Word marks are not required at either the A- or B-addresses, because this instruction involves a single character.

Timing. $T = .0115 (L_1 + 3)$ ms.

Address Registers After Operation.

I-Add. Reg.	A-Add. Reg.	B-Add. Reg.
NSI	A-1	B-1

Example. Move the zone bits from the units position of NEWBAL (3100) to the area labeled REC2 (3195), Figure 54.

SPS															
LINE	COUNT	LABEL	OPERATION	(A) OPERAND				(B) OPERAND							
				ADDRESS	±	CHAR. ADJ.	±	ADDRESS	±	CHAR. ADJ.	±				
3	8	7	9	13	14	16	17	23	24	27	28	34	35	38	39
0	1	0		MZ				NEWBAL				REC2			

Autocoder										
Label	Operation	OPERAND								
6	15	16	20	21	25	30	35	40	45	50
		MLZS			NEWBAL				REC2	

Assembled Instruction: Y A00 A95

Figure 54. Move Zone

Load Characters to A Word Mark

Instruction Format.

Mnemonic	Op Code	A-address	B-address
SPS LCA	<u>L</u>	xxx	xxx
A MLCWA			

Function. This instruction is commonly used to load data into the printer or punch areas of storage, and also to transfer data or instructions from the read-in area to another storage area. The data and word mark from the A-field are transferred to the B-field, and all other word marks in the B-field are cleared.

Editing

Editing, in the IBM 1401 Data Processing System, means punctuating printed output data, and includes the automatic control of zero suppression, and the insertion of identifying symbols. A single edit instruction causes all desired commas, decimals, dollar signs, asterisks, credit symbols, and minus signs to be automatically inserted in a numerical field. At the same time, unwanted zeros to the left of significant digits are suppressed (Figure 57).

OP	A-address	B-address	
<u>E</u>	789	300	
Storage	A-field (data) 00257426	B-field (control word) \$ bbb, bb0.bb & CR & **	
Result of edit	00257426	\$ 2,574.26	**

Figure 57. Editing

In editing, two fields are needed: the data field, and the control field. The control field governs how the numerical information in the data field is to be edited. It not only specifies the location of identifying symbols, but also controls the printing of zeros. The two fields are compared, character-by-character, under control of *editing rules*.

The control word has two parts: the *body* (which punctuates the A-field), and the *status* portion (which contains the dollar sign, sign-symbols, and class of total asterisks). The sign of the A-field determines whether or not sign-symbols will print. The sign of the A-field is removed.

To edit a field, a LOAD CHARACTERS TO A WORD MARK instruction loads the control word into the printer output area. This puts the control word where the edited information will eventually go. Then, a MOVE CHARACTERS AND EDIT instruction (with the same B-address as the previous load instruction) performs the editing function as it moves the data to the output area.

Note: A one-position field cannot be edited.

Move Characters and Edit

Instruction Format.

Mnemonic	Op Code	A-address	B-address
MCE	<u>E</u>	xxx	xxx

Function. The MOVE CHARACTERS AND EDIT instruction modifies the data in the A-field by the contents of the edit-control word in the B-field, and stores the result in the B-field. The following set of rules controls the editing operation.

Rule 1. All numerical, alphabetic, and special characters can be used in the control word. However, some of these have special meanings:

<u>Control Character</u>	<u>Function</u>	
b (blank)	This is replaced with the character from the corresponding position of the A-field.	
0 (zero)	This is used for zero suppression, and is replaced with a corresponding character from the A-field. Also the right-most "0" in the control word indicates the right-most limit of zero suppression.	
.	(decimal)	This remains in the edited field in the position where written. It is removed during a zero-suppress operation if it is to the left of the high-order significant digit. When used with the expanded print edit feature, it has an additional function (see <i>Expanded Print Edit</i>).
,	(comma)	This remains in the edited field in the position where written. It is removed during a zero-suppress operation if it is to the left of the high-order significant digit.
CR (credit)	This is undisturbed if the data sign is negative. It is blanked out if the data sign is positive. It can be used in body of control word without being subject to sign control.	
- (minus)	This is the same as CR.	
& (ampersand)	This causes a space in the edited field. It can be used in multiples.	
*	(asterisk)	This can be used in singular or in multiples, usually to indicate class of total. When it is used with the expanded print edit feature, it takes on an additional function (see <i>Expanded Print Edit</i>).
\$ (dollar sign)	This is undisturbed in the position where it is written. When used with the expanded print edit feature, it has an additional function (see <i>Expanded Print Edit</i>).	

Rule 2. A word mark in the high-order position of the B-field controls the MOVE CHARACTERS AND EDIT operation.

Rule 3. When the A-field word mark is sensed, the remaining commas in the control field are set to blanks.

Rule 4. The body of the control word is that portion beginning with the right-most blank or zero, and continuing to the left to the control character that governs the transfer of the last position of the data field. The remaining portion of the control field is the *status* portion.

Rule 5. If the data field is positive, and if the CR or - symbols are located in the status portion of the control word, they are blanked out.

Cycle	TYPE OF CYCLE	ADDRESS REGISTERS			REG.		PUT BACK INTO STORAGE	"B" FIELD AT END OF CYCLE	REMARKS
		I	A	B	B	A			
1	I _{op}	002	?	?	<u>E</u>		<u>E</u>	\$ b b b , b b 0 . b b & C R & * *	Read Instr. OP Code
2	I ₁	003	07bb	07bb	7	7	7	same	Load A Address Register
3	I ₂	004	078b	078b	8	8	8	same	Load A Address Register
4	I ₃	005	0789	0789	9	9	9	same	Load A Address Register
5	I ₄	006	0789	03bb	3	3	3	same	Load B Address Register
6	I ₅	007	0789	030b	0	0	0	same	Load B Address Register
7	I ₆	008	0789	0300	0	0	0	same	Load B Address Register
8	I ₇	008	0789	0300	<u>OP</u>	0	<u>OP</u>	same	OP code of next instr.
9	A	008	0788	0300	6	6	6	same	Execute EDIT instr.
10	B	008	0788	0299	*	6	*	same	Rule 1
11	B	008	0788	0298	*	6	*	same	Rule 1
12	B	008	0788	0297	&	6	Blank	\$ b b b , b b 0 . b b & C R b * *	Rule 1
13	B	008	0788	0296	R	6	Blank	\$ b b b , b b 0 : b b & C b b * *	Rule 1 and 5
14	B	008	0788	0295	C	6	Blank	\$ b b b , b b 0 . b b & b b b * *	Rule 1 and 5
15	B	008	0788	0294	&	6	Blank	\$ b b b , b b 0 . b b b b b b * *	Rule 1
16	B	008	0788	0293	b	6	6	\$ b b b , b b 0 . b 6 b b b b * *	Rule 1
17	A	008	0787	0293	2	2	2	same	Rule 1
18	B	008	0787	0292	b	2	2	\$ b b b , b b 0 . 2 6 b b b b * *	Rule 1
19	A	008	0786	0292	4	4	4	same	Rule 1
20	B	008	0786	0291	.	4	.	same	Rule 1
21	B	008	0786	0290	0	4	4	\$ b b b , b b 4 . 2 6 b b b b * *	Zero Suppress—Rule 1 and 6
22	A	008	0785	0290	7	7	7	same	Rule 1
23	B	008	0785	0289	b	7	7	\$ b b b , b 7 4 . 2 6 b b b b * *	Rule 1
24	A	008	0784	0289	5	5	5	same	Rule 1
25	B	008	0784	0288	b	5	5	\$ b b b , 5 7 4 . 2 b b b b b * *	Rule 1
26	A	008	0783	0288	2	2	2	same	Rule 1
27	B	008	0783	0287	,	2	,	same	Rule 1
28	B	008	0783	0286	b	2	2	\$ b b 2 , 5 7 4 . 2 6 b b b b * *	Rule 1
29	A	008	0782	0286	0	0	0	same	Rule 1
30	B	008	0782	0285	b	0	0	\$ b 0 2 , 5 7 4 . 2 6 b b b b * *	Rule 1
31	A	008	0781	0285	<u>0</u>	<u>0</u>	<u>0</u>	same	Rule 1
32	B	008	0781	0284	b	<u>0</u>	0	\$ 0 0 2 , 5 7 4 . 2 6 b b b b * *	Rule 1
33	B	008	0781	0284	\$	<u>0</u>	\$	\$ 0 0 2 , 5 7 4 . 2 6 b b b b * *	Sense Word Mark—Rev. Scan—Rule 1 and 6
34	B	008	0781	0285	\$	<u>0</u>	\$	same	Rule 6
35	B	008	0781	0286	0	<u>0</u>	Blank	\$ b 0 2 , 5 7 4 . 2 6 b b b b * *	Rule 6
36	B	008	0781	0287	0	<u>0</u>	Blank	\$ b b 2 , 5 7 4 . 2 6 b b b b * *	Rule 6
37	B	008	0781	0288	2	<u>0</u>	2	same	Rule 6
38	B	008	0781	0289	,	<u>0</u>	,	same	Rule 6
39	B	008	0781	0290	5	<u>0</u>	5	same	Rule 6
40	B	008	0781	0291	7	<u>0</u>	7	same	Rule 6
41	B	008	0781	0292	<u>4</u>	<u>0</u>	4	\$ b b 2 , 5 7 4 . 2 6 b b b b * *	Rule 6

Figure 58. Step-by-Step Editing Operation

A-field	0010900
Control word (B-field)	\$ bb, bb0. bb
Forward scan	\$ 00,109. 00
Reverse scan	\$ bbb109. 00
Results of edit	\$ 109. 00

Figure 59. Zero Suppression

Rule 6. Zero suppression is used if unwanted zeros to the left of significant digits in a data field are to be deleted (Figure 59).

A special zero is placed (in the body of the control word) in the right-most limit of zero suppression.

To properly perform zero-suppression operations there must be at least one character to the left of the zero-suppression character in the control word.

Forward Scan:

1. The positions in the output field at the right of this special zero are replaced by the corresponding digits from the A-field.
2. The special zero is replaced by the corresponding digit from the A-field, when it is detected in the control field.
3. A word mark is automatically set in this position of the B- (output) field.
4. The scan continues until the B-field (high order) word mark is sensed and removed.

Reverse Scan:

1. In the output field, blanks replace all zeros and punctuation, except hyphens at the left of the first significant character (up to and including the zero suppression code position).

2. When the automatically-set zero suppression word mark is sensed, it is erased and the operation ends.

Rule 7. The data field can contain fewer, but must not contain more positions than the number of blanks and zeros in the body of the control word. Dollar signs and asterisks are included in the body of the control word with the expanded print edit special feature.

Figure 58 shows the use of these rules as applied to the data in Figure 57.

Timing. $T = .0115 (L_I + 1 + L_A + L_B + L_X)$ ms.

Address Registers After Operation.

	I-Add. Reg.	A-Add. Reg.	B-Add. Reg.
Without zero suppression	NSI	A-address minus the length of the A-field.	B-L _B
With zero suppression	NSI	A-address minus the length of the A-field.	Location of the special control zero plus 1.

Example. Edit the data labeled GROPAY (0985) by the edit-control word EDCONT (0325). Store the result in PRINT6 (0250), Figure 60.

LINE	COUNT	LABEL	OPERATION	(A) OPERAND				(B) OPERAND				
				ADDRESS	CHAR. ADJ.	CHAR. ADJ.	ADDRESS	CHAR. ADJ.	CHAR. ADJ.	ADDRESS		
5	0, 1, 0		LCA	EDCONT				PRINT6				
0	2, 0		MCE	GROPAY				PRINT6				

Label	Operation	OPERAND
MCE	EDCONT, PRINT6	
MCE	GROPAY, PRINT6	

Assembled Instruction: L 325 250
E 985 250

Figure 60. Edit

Input-Output Operations

This section describes the timing and operation codes the 1401 uses to control card reading, card punching, and printing. Several, different, combination operation codes make it possible to perform multiple functions: card reading and punching; printing and reading; printing, reading and punching; etc. Instruction format flexibility permits automatic program branching.

Card Read Instructions

The card reader operates at a rated speed of 800 cycles per minute (one cycle every 75 milliseconds). The card reading speed depends on the timing of the READ A CARD instructions in the program. To effect continuous card-reading at the rate of 800 cards per minute, a READ A CARD instruction must be given within 10 milliseconds after the preceding card has been actually read into the IBM 1401 Processing Unit. If more than 10 milliseconds are required for processing, the card read speed drops to 400 cards per minute. This happens because of the mechanical structure of the card feed. There is only one point in the cycle during which a card can feed, and if no read impulse signals the feed at that time, the reader will be delayed for 75 milliseconds (or until the same point in the following cycle).

The read release special feature permits job time improvements by allowing more actual processing time during the read cycle.

Read a Card

Instruction Format.

Mnemonic Op Code
 R 1

Function. This code causes a card to feed, and causes all 80 columns of information to be read into core-storage locations 001 through 080.

Word Marks. Word marks are undisturbed.

$$\text{Timing. } T = .0115 (L_I + 1) \text{ ms} + I/O.$$

A card read cycle requires a total of 75 milliseconds. The cycle is divided into three major operations (Figure 61):

1. Read start time is 21 ms. The read instruction must be given prior to card reading time in order to activate the card feed for that particular cycle. If the read instruction is given too late in the cycle, processing is delayed until the next card reading time occurs in the following read cycle. The processing unit is interlocked during *read start time* unless the read release special feature is installed.
2. Card read time is 44ms. The actual reading of the card takes place during this part of the cycle and the data is read into core storage. The processing unit is interlocked during *card reading time*.
3. Processing time is 10 ms. This part of the cycle is for processing. If *processing time* requires more than 10 milliseconds, the reader speed drops from 800 to 400 cards per minute.

Note. The processing time allowed is increased if the read release special feature is included in the system (see *Read Release*).

Address Registers After Operation.

I-Add. Reg. A-Add. Reg. B-Add. Reg.
 NSI Ap 081

Example. Read a card (Figure 62).

SPS

LINE	COUNT	LABEL	OPERATION	(A) OPERAND				(B) OPERAND				d	
				ADDRESS	±	CHAR. ADL.	±	ADDRESS	±	CHAR. ADL.	±		
0	1		R										

Autocoder

Label	Operation	OPERAND							
15	16	20	21	25	30	35	40	45	50
	R								

Assembled Instruction: 1

Figure 62. Read Card

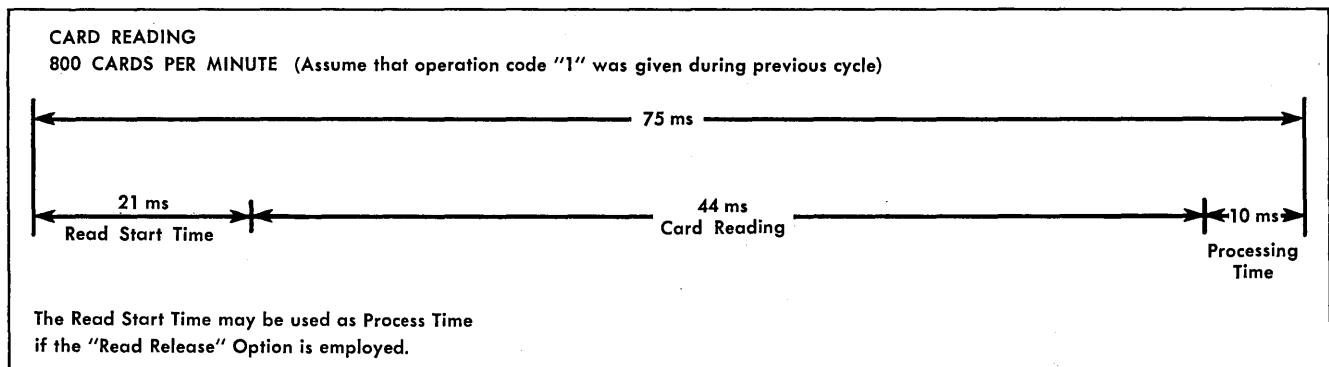

Figure 61. Card Read Cycle

Read and Branch

Instruction Format.

Mnemonic	Op Code	I-address
R	<u>1</u>	xxx

Function. This is the same as the READ A CARD instruction, except that the next instruction is taken from the I-address instead of from the next sequential instruction address. The program branch occurs after the card has been read into storage.

Word Marks. Word marks are not affected.

Timing. $T = .0115 (L_I + 1) \text{ ms} + I/O.$

Address Registers After Operation.

I-Add. Reg.	A-Add. Reg.	B-Add. Reg.
NSI	BI	081

Example. Read a card, and branch to CALC1 (1500), Figure 63.

SPS		(A) OPERAND										(B) OPERAND									
LINE	COUNT	LABEL			OPERATION			ADDRESS		±	CHAR. ADJ.	±	CHAR. ADJ.	ADDRESS		±	CHAR. ADJ.	±	CHAR. ADJ.		
3	8	7	8	13	14	16	17	23	23		27	28	34	34		38	39		43	44	
0	1	0				R		C	A	L	C	1									

Autocoder									
Label	Operation	OPERAND							
9	13-18	20-21	25	30	35	40	45	50	
R		C	A	L	C	1			

Assembled Instruction: 1 V00

Figure 63. Read Card and Branch

Punch Instructions

The card punch operates at a rated speed of 250 cycles per minute (240 ms per cycle). Actual card punching, at an optimum rate of 250 cards per minute, is controlled by punch instructions in the program.

There are four points in the cycle (occurring at 60 millisecond intervals) when the punch feeding mechanism can receive an impulse to start the punch cycle.

The punch cycle is divided into three separate functions (Figure 64).

1. Punch start time is 37 ms. After the feed mechanism has been impulsed, the time required for the card to feed and be positioned for punching is called *punch start time*. The IBM 1401 Processing Unit is interlocked during punch start time unless punch release special feature is employed.
2. Card punching time is 181 ms. The actual punching of the card takes place during this part of the cycle. The IBM 1401 Processing Unit is always interlocked during *card-punching time*.
3. Processing time is 22 ms. This is the remainder of the punch cycle that is allotted for *processing* in the 1401 unit.

If the punch release special feature is used in the system, a total of 59 ms are available for processing (see *Start Punch Feed*). In a system with the punch feed read special feature, 57 ms are available for processing.

During card-punching time, the card feeds past the punch station 12-edge first. At the appropriate digit times, the information from storage locations 101-180 is emitted in BCD code; is translated into IBM card code; and is punched in the corresponding card columns. The information in the storage punch area (101-180) is undisturbed, and can be removed by a CLEAR STORAGE instruction.

Punch a Card

Instruction Format.

Mnemonic	Op Code
P	<u>4</u>

Function. The data in storage locations 101 through 180 is punched into an IBM card.

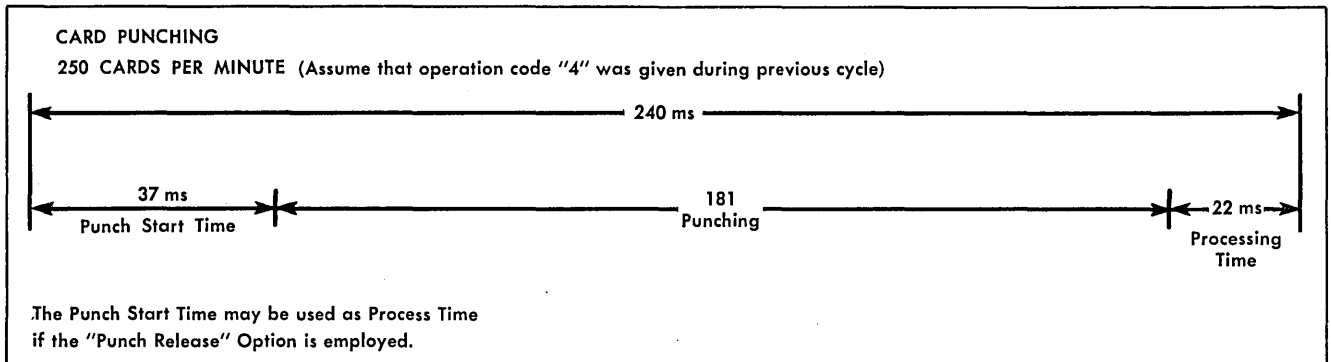

Figure 64. Punch Cycle

Word Marks. Word marks are not affected.

Timing. $T = .0115 (L_I + 1) \text{ ms} + I/O.$

Address Registers After Operation.

I-Add. Reg. A-Add. Reg. B-Add. Reg.
 NSI Ap 181

Example. Feed a card, and punch (Figure 65).

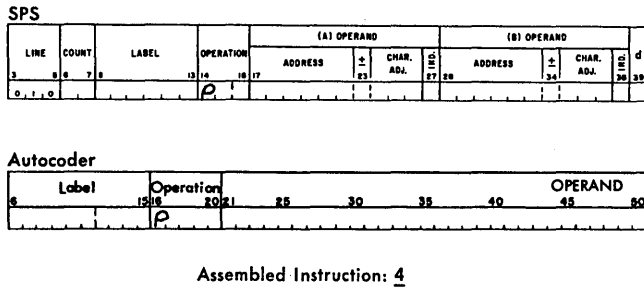

Figure 65. Punch

Punch and Branch

Instruction Format.

Mnemonic Op Code I-address
 P 4 XXX

Function. This is the same as the PUNCH A CARD instruction, except that the next instruction is taken from the I-address instead of from the next sequential instruction address. The branch occurs after the card has been punched.

Word Marks. Word marks are not affected.

Timing. $T = .0115 (L_I + 1) \text{ ms} + I/O.$

Address Registers After Operation.

I-Add. Reg. A-Add. Reg. B-Add. Reg.
 NSI BI 181

Example. Punch a card, and branch to START1 (1758), Figure 66.

SPS

LINE	COUNT	LABEL	OPERATION	(A) OPERAND				(B) OPERAND				d	
				ADDRESS	±	CHAR. ADJ.	IN	ADDRESS	±	CHAR. ADJ.	IN		
3	0	7	P	15	16	17							
0	1	0											

Autocoder

Label	Operation	OPERAND
P	4	START1

Assembled Instruction: 4 X58

Figure 66. Punch and Branch

Print Instructions

The IBM 1403 prints at a maximum rate of 600 lines per minute. When a WRITE A LINE instruction is interpreted the data in the print area (addresses 201 through 300 in the basic IBM 1403, and addresses 201-332 in a 1403 equipped with additional print positions) is transferred character-by-character to the printer. The printer spaces once after each line is printed, unless impulsed to do otherwise. The printer operates only when impulsed to print. Thus, the print cycle is started when needed and the printer immediately starts to print at the beginning of the cycle. The 100-millisecond print cycle is subdivided (Figure 67).

1. Print time is 84 ms. The line is printed during this part of the cycle. The IBM 1401 Processing Unit is interlocked during *print time* unless the print storage special feature is employed.
2. Process time is 16 ms. This is the normal *processing time* available during the print cycle (see *Print Storage*).
3. Form movement time is 20 ms. The normal *form movement time* (one space) is always overlapped by processing time. Skipping time is not overlapped and must be included in the calculation of total program time.

An internal check is performed to insure that the character set up at the print mechanism is the same as that sent from storage.

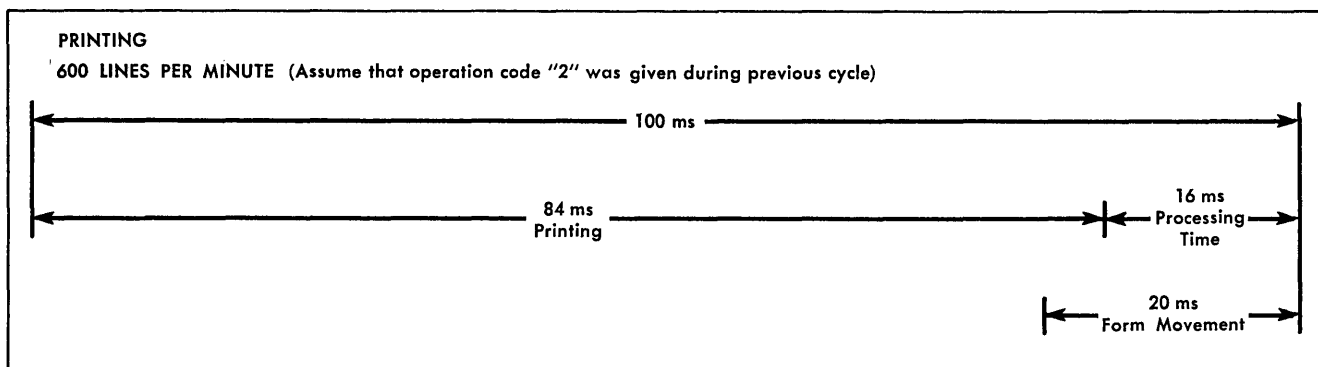

Figure 67. Print Cycle

Write a Line

Instruction Format.

Mnemonic *Op Code*
W 2

Function. This instruction causes the data in the print area to be transferred to the printer. The program continues after printing is complete. The printer takes one automatic space after printing a line.

Word Marks. Word marks are not affected.

Timing. $T = .0115 (L_I + 1) \text{ ms} + \text{I/O.}$

Note. The normal 84 ms-interlock during printing can be greatly reduced, if the print storage special feature is installed (see *Print Storage*).

Address Registers After Operation.

I-Add. Reg. *A-Add. Reg.* *B-Add. Reg.*
NSI Ap 335
333 (print storage)

Example. Print the data in the print area (Figure 68).

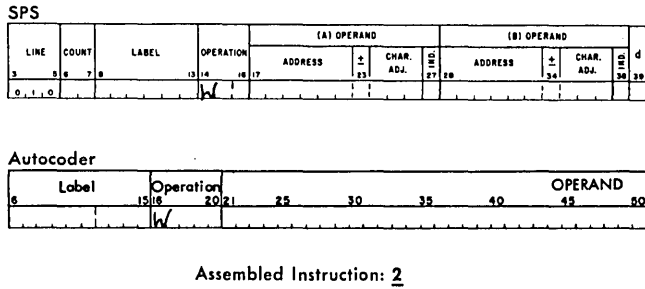

Figure 68. Print

Write and Branch

Instruction Format.

Mnemonic *Op Code* *I-address*
W 2 XXX

Function. This is the same as the WRITE A LINE instruction, except that the next instruction after printing is taken from the I-address.

Word Marks. Word marks are not affected.

Timing. $T = .0115 (L_I + 1) \text{ ms} + \text{I/O.}$

Address Registers After Operation.

I-Add. Reg. *A-Add. Reg.* *B-Add. Reg.*
NSI BI 335
333 (print storage)

Example. Print, and branch to STREC (0678) for the next instruction (Figure 69).

SPS

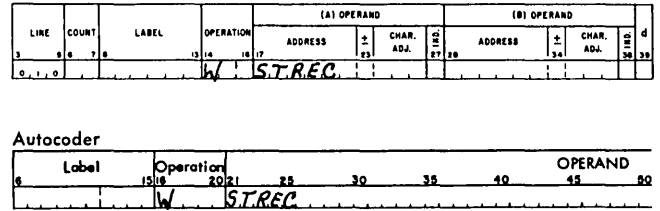

Assembled Instruction: 2 678

Figure 69. Print and Branch

Write Word Marks

Instruction Format.

Mnemonic *Op Code* *d-character*
SPS W 2 \square
A WM

Function. The word marks associated with storage addresses in the print area print as the digit 1 in the corresponding print positions. After printing, the machine takes an automatic space, unless otherwise impuised. The \square causes the word marks to be transferred to the printer.

Word Marks. Word marks remain in their original positions in the print area.

Timing. $T = .0115 (L_I + 1) \text{ ms} + \text{I/O.}$

Address Registers After Operation

I-Add. Reg. *A-Add. Reg.* *B-Add. Reg.*
NSI dbb 335
333 (print storage)

Example. Print all word marks in the print area (Figure 70).

SPS

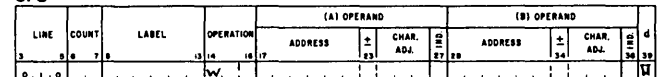

Autocoder

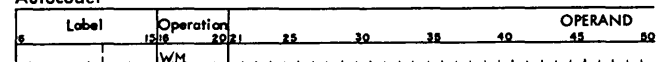

Assembled Instruction: 2 \square

Figure 70. Print Word Marks

Write Word Marks and Branch

Instruction Format.

Mnemonic	Op Code	I-address	d-character
SPS W	<u>2</u>	xxx	□
A WM			

Function. This is the same as WRITE WORD MARKS (2 □) instruction, except that the next instruction is taken from the I-address instead of from the next sequential instruction.

Word Marks. Word marks remain in their original positions in the print area.

Timing. $T = .0115 (L_I + 1) \text{ ms} + \text{I/O}$.

Address Registers After Operation.

I-Add. Reg.	A-Add. Reg.	B-Add. Reg.
NSI	BI	335
		333 (print storage)

Example. Print word marks, and branch to RESTAR (0890), Figure 71.

SPS														
LINE	COUNT	LABEL	OPERATION	(A) OPERAND				(B) OPERAND				d		
				ADDRESS	±	CHAR. ADJ.	±	CHAR. ADJ.	±	CHAR. ADJ.				
3	8	7	8	13	14	15	17	18	19	20	21	22	23	24
0	1	0	W	R	E	S	T	A	R					

Autocoder													
Label	Operation	OPERAND											
6	15	20	21	25	30	35	40	45	50	55	60	65	70
WM	WR	R	E	S	T	A	R						

Assembled Instruction: 2 890 □

Figure 71. Print Word Marks and Branch

Combination Instructions

It is often practical to combine two or three input/output functions in one instruction. Several special operation codes are provided to make it possible to perform some operations simultaneously. Each combination instruction has a corresponding instruction that permits automatic branching to a predetermined instruction address after the functions are complete.

Write and Read

Instruction Format.

Mnemonic	Op Code
WR	<u>3</u>

Function. This instruction combines the functions of READ A CARD (1) and WRITE A LINE (2). The printer takes priority, and the print cycle is completed

before the actual card reading operation takes place. However, the signal to start the reader can be accepted before the end of the print cycle. Thus, read start time overlaps the print cycle.

Word Marks. Word marks are not affected.

Timing. $T = .0115 (L_I + 1) \text{ ms} + \text{I/O}$.

Note. If the system is equipped with the print storage special feature, the read operation can be performed as soon as the data is received in print storage.

Address Registers After Operation.

I-Add. Reg.	A-Add. Reg.	B-Add. Reg.
NSI	Ap	081

Example. Print a line, and read a card Figure 72.

SPS														
LINE	COUNT	LABEL	OPERATION	(A) OPERAND				(B) OPERAND				d		
				ADDRESS	±	CHAR. ADJ.	±	CHAR. ADJ.	±	CHAR. ADJ.				
3	8	7	8	13	14	15	17	18	19	20	21	22	23	24
0	1	0	WR											

Autocoder													
Label	Operation	OPERAND											
6	15	20	21	25	30	35	40	45	50	55	60	65	70
WR	WR												

Assembled Instruction: 3

Figure 72. Print and Read

Write, Read, and Branch

Instruction Format.

Mnemonic	Op Code	I-address
WR	<u>3</u>	xxx

Function. This is the same as the WRITE AND READ instruction, except that the next instruction is taken from the I-address.

Word Marks. Word marks are not affected.

Timing. $T = .0115 (L_I + 1) \text{ ms} + \text{I/O}$.

Address Registers After Operation.

I-Add. Reg.	A-Add. Reg.	B-Add. Reg.
NSI	BI	081

Example. Print a line, read a card, and branch to CALC2 (0759), Figure 73.

LINE		COUNT	LABEL	OPERATION	(A) OPERAND				(B) OPERAND				d		
3	6	7	13	14	15	16	17	18	19	20	21	22	23	24	25
0	1	0		WR	C	A	L	C	2						

6	Label	15	16	Operation	20	21	25	30	35	40	45	50	OPERAND
				WR	C	A	L	C	2				

Assembled Instruction: 3 759

Figure 73. Print, Read, and Branch

Read and Punch

Instruction Format.

Mnemonic	Op Code
RP	<u>5</u>

Function. The functions of READ A CARD (1) and PUNCH A CARD (4) are combined in this operation code. The two operations overlap and, in effect, occur simultaneously.

Word Marks. Word marks are not affected.

Timing. $T = .0115 (L_I + 1) \text{ ms} + \text{I/O.}$

Address Registers After Operation.

I-Add. Reg.	A-Add. Reg.	B-Add. Reg.
NSI	Ap	181 OR 081

Note: The B-address register normally stands at 181 unless reading is completed after punching. In this case the B-address register contains 081.

Example. Read a card into the input area, and punch a card with information from the punch area (Figure 74).

LINE		COUNT	LABEL	OPERATION	(A) OPERAND				(B) OPERAND				d		
3	6	7	13	14	15	16	17	18	19	20	21	22	23	24	25
0	1	0		RP											

6	Label	15	16	Operation	20	21	25	30	35	40	45	50	OPERAND
				RP									

Assembled Instruction: 5

Figure 74. Read and Punch

Read, Punch, and Branch

Instruction Format.

Mnemonic	Op Code	I-address
RP	<u>5</u>	xxx

Function. This is the same as the READ AND PUNCH instruction except that the next instruction is located at the I-address.

Word Marks. Word marks are not affected.

Timing. $T = .0115 (L_I + 1) \text{ ms} + \text{I/O.}$

Address Registers After Operation.

I-Add. Reg.	A-Add. Reg.	B-Add. Reg.
NSI	BI	181 OR 081

(See note under *Read and Punch.*)

Example. Read, punch, and branch to WORK5 (0596), Figure 75.

LINE		COUNT	LABEL	OPERATION	(A) OPERAND				(B) OPERAND				d		
3	6	7	13	14	15	16	17	18	19	20	21	22	23	24	25
0	1	0		RP	W	O	R	K	5						

6	Label	15	16	Operation	20	21	25	30	35	40	45	50	OPERAND
				RP	W	O	R	K	5				

Assembled Instruction: 5 596

Figure 75. Read, Punch, and Branch

Write and Punch

Instruction Format.

Mnemonic	Op Code
WP	<u>6</u>

Function. This code combines the WRITE A LINE (2) and PUNCH A CARD (4) instructions. The printer always operates first, but the signal to start the punch is automatically given before the end of the print operation, so that actual card punching starts soon after the print cycle is complete.

Word Marks. Word marks are not affected.

Timing. $T = .0115 (L_I + 1) \text{ ms} + \text{I/O.}$

Note. If the print storage special feature is installed, the signal to start the punch is received shortly after the transfer of data to the print storage area.

Address Registers After Operation.

I-Add. Reg. A-Add. Reg. B-Add. Reg.
 NSI Ap 181

Example. Write a line, and punch a card (Figure 76).

SPS				(A) OPERAND								(B) OPERAND							
LINE	COUNT	LABEL	OPERATION	ADDRESS		±	CHAR. ADJ.	ADDRESS		±	CHAR. ADJ.	ADDRESS		±	CHAR. ADJ.	d			
3	6	7	8	13	14	16	17	23	24	25	27	28	34	35	36	37			
0	1	0																	
			WP																

Autocoder											
Label	Operation		OPERAND								
6	15	20	25	30	35	40	45	50	55	60	65
		WP									

Assembled Instruction: 6

Figure 76. Print and Punch

Write, Punch, and Branch

Instruction Format.

Mnemonic Op Code I-address
 WP 6 XXX

Function. This is the same as WRITE AND PUNCH, except that the program branches automatically to the location in the I-address after punching is completed.

Word Marks. Word marks are not affected.

Timing. $T = .0115 (L_I + 1) \text{ ms} + \text{I/O.}$

Note. If the print storage special feature is installed, the signal to start the punch is received shortly after the transfer of data to the print storage area.

Address Registers After Operation.

I-Add. Reg. A-Add. Reg. B-Add. Reg.
 NSI BI 181

Example. Read, punch, and branch to AREA8 (0895), Figure 77.

SPS				(A) OPERAND								(B) OPERAND							
LINE	COUNT	LABEL	OPERATION	ADDRESS		±	CHAR. ADJ.	ADDRESS		±	CHAR. ADJ.	ADDRESS		±	CHAR. ADJ.	d			
3	6	7	8	13	14	16	17	23	24	25	27	28	34	35	36	37			
0	1	0																	
			WP	AREA8															

Autocoder											
Label	Operation		OPERAND								
6	15	20	25	30	35	40	45	50	55	60	65
		WP	AREA8								

Assembled Instruction: 6 895

Figure 77. Print, Punch, and Branch

Write, Read, and Punch

Instruction Format.

Mnemonic Op Code
 WRP 7

Function. Printing, reading, and punching operations are performed when this command is given. The printer takes priority, and the reading and punching cycles start before the end of the actual print operation.

Word Marks. Word marks are not affected.

Timing. $T = .0115 (L_I + 1) \text{ ms} + \text{I/O.}$

Address Registers After Operation.

I-Add. Reg. A-Add. Reg. B-Add. Reg.
 NSI Ap 181
 or
 081

(See note under Read and Punch.)

Example. Write, read, and punch (Figure 78).

SPS				(A) OPERAND								(B) OPERAND							
LINE	COUNT	LABEL	OPERATION	ADDRESS		±	CHAR. ADJ.	ADDRESS		±	CHAR. ADJ.	ADDRESS		±	CHAR. ADJ.	d			
3	6	7	8	13	14	16	17	23	24	25	27	28	34	35	36	37			
0	1	0																	
			WRP																

Autocoder											
Label	Operation		OPERAND								
6	15	20	25	30	35	40	45	50	55	60	65
		WRP									

Assembled Instruction: 7

Figure 78. Print, Read, and Punch

Write, Read, Punch, and Branch

Instruction Format.

Mnemonic Op Code I-address
 WRP 7 XXX

Function. This is the same as WRITE, READ, AND PUNCH except that the next instruction, after punching is completed, is taken from the I-address.

Word Marks. Word marks are not affected.

Timing. $T = .0115 (L_I + 1) \text{ ms} + \text{I/O.}$

Address Registers After Operation.

I-Add. Reg. A-Add. Reg. B-Add. Reg.
 NSI BI 181
 or
 081

(See note under Read and Punch.)

Example. Branch to ROUT4 (0980) after a line is printed, a card is read, and a card is punched (Figure 79).

SPS													
LINE	COUNT	LABEL	OPERATION	(A) OPERAND				(B) OPERAND				d	
				ADDRESS	\pm	CHAR. ADJ.	IND	ADDRESS	\pm	CHAR. ADJ.	IND		
3	8	7		13	14	15	16	17	18	19	20	21	
0	1	0		WRP				ROUT4					

Autocoder												
s	Label	15	16	17	18	19	20	21	22	23	24	
		OPERATION									OPERAND	
6												
		WRP									ROUT4	

Assembled Instruction: Z 980

Figure 79. Print, Read, Punch, and Branch

Example. Enter the last card read into pocket 1 (Figure 80).

SPS													
LINE	COUNT	LABEL	OPERATION	(A) OPERAND				(B) OPERAND				d	
				ADDRESS	\pm	CHAR. ADJ.	IND	ADDRESS	\pm	CHAR. ADJ.	IND		
3	8	7		13	14	15	16	17	18	19	20	21	
0	1	0		SS									

Autocoder										
s	Label	15	16	17	18	19	20	21	22	23
		OPERATION								OPERAND
6										
		SS								1

Assembled Instruction: K 1

Figure 80. Select Stacker

Document Control Instructions

Select Stacker

Instruction Format.

Mnemonic	Op Code	d-character
SS	<u>K</u>	x

Function. This instruction causes the card that was just read or punched to be selected into the stacker pocket specified by the d-character:

d-character	Feed	Stacker Pocket
1	READ	1
2	READ	8/2
4	PUNCH	4
8	PUNCH	8/2

Read Select. A SELECT STACKER instruction must be given during the first 10 ms after actual card reading is completed. Otherwise the command is ineffective. After a card is read, it continues to the stackers without stopping. Therefore, if no SELECT STACKER signal is received within the next 10 ms the card stacks in the NORMAL stacker (NR). Read select instructions cannot be used following RP and WRP instructions because the select signal cannot be given within the prescribed 10 milliseconds.

Punch Select. The SELECT STACKER instruction is effective if given at any time between two PUNCH A CARD instructions. However, if a punch check occurs, the error card is directed to the NORMAL (NP) stacker.

Word Marks. Word marks are not affected.

Timing. $T = .0115 (L_I + 1)$ ms.

Address Registers After Operation.

I-Add. Reg.	A-Add. Reg.	B-Add. Reg.
NSI	dbb	dbb

Select Stacker and Branch

Instruction Format.

Mnemonic	Op Code	I-address	d-character
SPS SS	<u>K</u>	xxx	x
A SSB			

Function. This is the same as SELECT STACKER, except that the next instruction is taken from the I-address.

Word Marks. Word marks are not affected.

Timing. $T = .0115 (L_I + 1)$ ms.

Address Registers After Operation.

I-Add. Reg.	A-Add. Reg.	B-Add. Reg.
NSI	BI	dbb

Example. Select the last card punched, enter it in pocket 4, and branch to ROUT5 (0950) for the next instruction (Figure 81).

SPS													
LINE	COUNT	LABEL	OPERATION	(A) OPERAND				(B) OPERAND				d	
				ADDRESS	\pm	CHAR. ADJ.	IND	ADDRESS	\pm	CHAR. ADJ.	IND		
3	8	7		13	14	15	16	17	18	19	20	21	
0	1	0		SS				ROUT5					

Autocoder										
s	Label	15	16	17	18	19	20	21	22	23
		OPERATION								OPERAND
6										
		SS								ROUT5

Assembled Instruction: K 950 4

Figure 81. Select Stacker and Branch

Control Carriage

Instruction Format.

Mnemonic	Op Code	d-character
CC	<u>F</u>	x

Function. This instruction causes the carriage to move as specified by the d-character. A digit causes an immediate skip to a specified channel in the carriage tape. An alphabetic character with a 12-zone causes a skip to a specified channel after the next line is printed. An alphabetic character with an 11-zone causes an immediate space. A zero-zone character causes a space after the next line is printed. The table (Figure 82). shows the function of the d-character. If the carriage is in motion when a CONTROL CARRIAGE instruction is given, the program stops until the carriage comes to rest. At this point, the new carriage action is initiated, and then the program advances to the next instruction in storage.

Word Marks. Word marks are not affected.

Timing. $T = .0115 (L_I + 1)$ ms plus remaining form-movement time, if carriage is moving when this instruction is given. The form-movement time is determined by the number of spaces the form moves. Allow 20 ms for the first space, plus 5 ms for each additional space.

d	Immediate skip to	d	Skip after print to
1	Channel 1	A	Channel 1
2	Channel 2	B	Channel 2
3	Channel 3	C	Channel 3
4	Channel 4	D	Channel 4
5	Channel 5	E	Channel 5
6	Channel 6	F	Channel 6
7	Channel 7	G	Channel 7
8	Channel 8	H	Channel 8
9	Channel 9	I	Channel 9
0	Channel 10	?	Channel 10
#	Channel 11	•	Channel 11
@	Channel 12	□	Channel 12
d	Immediate space	d	After print-space
J	1 space	/	1 space
K	2 spaces	S	2 spaces
L	3 spaces	T	3 spaces

Figure 82. d-Characters for Forms Control

Address Registers After Operation.

I-Add. Reg.	A-Add. Reg.	B-Add. Reg.
NSI	dbb	dbb

Example. Skip to channel 1 after print (Figure 83).

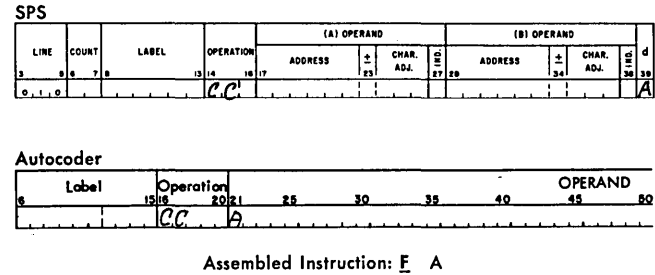

Figure 83. Forms Control

Control Carriage and Branch

Instruction Format.

Mnemonic	Op Code	I-address	d-character
SPS CC	<u>F</u>	xxx	x
A CCB			

Function. This format of the CONTROL CARRIAGE instruction causes a program branch to the location specified by the I-address for the next instruction after interpretation of the d-character.

Word Marks. Word marks are not affected.

Timing. $T = .0115 (L_I + 1)$ ms plus remaining form-movement time, if carriage is moving when this instruction is given. The form-movement time is determined by the number of spaces the form moves. Allow 20 ms for the first space, plus 5 ms for each additional space.

Address Registers After Operation.

I-Add. Reg.	A-Add. Reg.	B-Add. Reg.
NSI	BI	dbb

Example. Skip to channel 1 immediately, and branch to START3 (0498) for the next instruction (Figure 84).

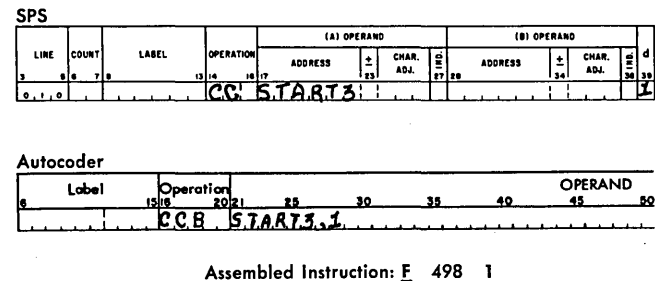

Figure 84. Forms Control and Branch

Page 52 — Control Carriage instruction, add:

Note: Care should be taken when punching channels 9 and 12 of the carriage control tape on a system with the print storage feature to insure that these punches will not be ignored by line spacing (single, double, or triple). This is necessary because the next tape channel sensed resets the channel 9 and the channel 12 indicators. The next hole punched in the carriage tape following a 9- or 12-punch should be at least $1 + S$ spaces from the 9- or 12-punch (S equals number of lines being spaced).

When an immediate skip or immediate space instruction is used, an additional space caused by the automatic carriage space taken after printing results. When a skip after print or space after print instruction is used, the automatic space is not taken.

An important feature in economical processing of business data is compact storage. A magnetic tape reel (10½ inches in diameter) contains 2,400 feet – enough tape to record as many as 14,000,000 characters. The tape itself is a ribbon, ½-inch wide, coated with a magnetic oxide material. Tape reels can be easily stored or transported from one installation to another. Also, magnetic tape records have gained wide acceptance as legal documents.

Data Flow

The IBM 1401 system accepts data from punched cards, magnetic tape, or both. Information is read into the system, rearranged, calculated, and edited by the stored program. Output can be in the form of punched cards, magnetic tape, or printed reports.

The 1401 Model D is not equipped with an IBM 1402 Card Read-Punch (Figure 85).

All data passes through 1401 core storage, where a series of validity checks insure accuracy and reliability.

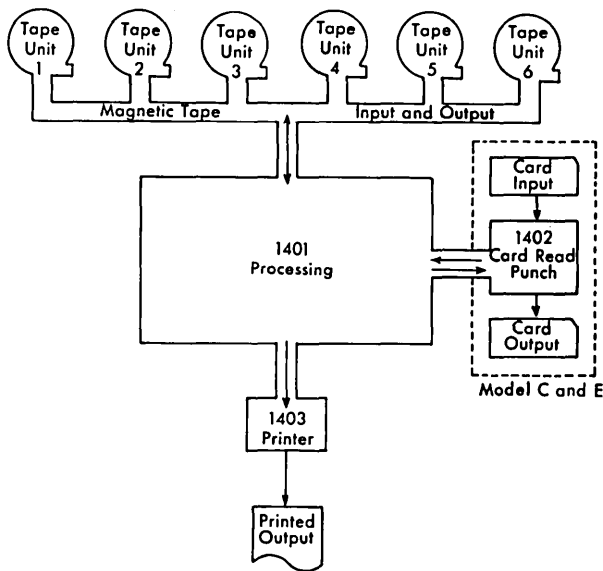

Figure 85. Data Flow Schematic, IBM 1401

Magnetic-Tape Characteristics

The magnetic-tape recording code used with the IBM 1401, is the same binary-coded-decimal code used with other IBM data processing systems. This compatibility permits interchanging tapes between installations that employ different IBM systems.

Data is recorded in a seven-bit code, in seven parallel channels along the tape. Figure 86 shows tape characters and their corresponding codes.

Records are separated from each other by approximately ¾ inch of blank (unrecorded) tape, called an *inter-record gap*.

Each tape character is composed of an even number of magnetic bits. A check bit (labeled C in Figure 87) is written if the number of bits in the other six positions is odd. An even-parity check on each character insures accuracy for tape-read and tape-write operations.

In addition to this vertical parity check, a horizontal check (HC in Figure 87) is made on each record. The bits in each horizontal row are automatically counted

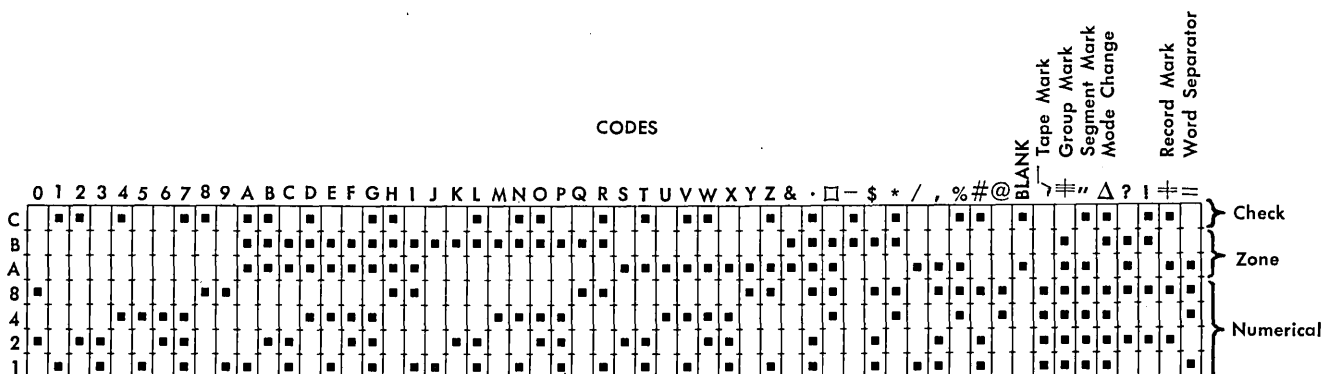

Figure 86. Magnetic Tape 7-Bit Coding

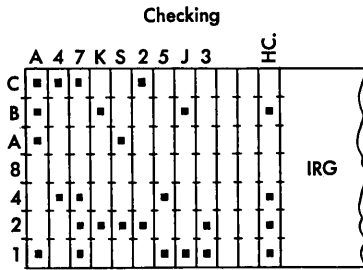

Figure 87. Vertical and Horizontal Check

when the record is written, and a bit (similar in function to the vertical-check bit) is written at the end of each odd-count row. The vertical combination of these horizontal-check bits makes up the horizontal-check character. Thus, the coding of this character can change from record to record. When the tape is read, the same automatic count is made, but now each row in the complete record should have an even number of bits, or an error exists. The horizontal-check character is used for checking only, and is never read into 1401 core storage.

To process even-bit parity tapes a U is used in the tens position of the A-address (%Ux). Odd-bit parity tapes can be processed by the 1401 by using a B in the tens position of the A-address (%Bx). The column binary special feature is not required to perform this operation.

When processing even-bit parity tapes, the A-bit character may have its bit structure changed to that of the blank character (C-bit) (Figure 88). That is, the A-bit is written on even-parity tape as CA bits; thus, when the tape is read, the character is translated as a C-bit only. Therefore, in order to retain the A-bit character, it should be written on odd-parity tape. The A-bit is then written on tape as an A-bit, and when read from tape, it returns to core-storage as an A-bit.

Processing Magnetic Tape for Use with the IBM 7070 Data Processing System

Because the IBM 7070 Data Processing System is a numerical machine (alphabetic characters are represented by two numbers), a special delta (Δ) character is used

to signal a mode change (from alphabetic to numerical and vice versa in a tape record).

When IBM 7070 tapes containing the delta character are read into 1401 core storage, the delta character is transferred just as any other tape character. Records can also be written from 1401 core storage with the delta character for subsequent use by a 7070. However, there is no automatic insertion of a delta character in 1401 tape-write operations on a mode change. The deltas must be inserted between numerical and alphabetic fields by the 1401 program if the records are not in core storage as a result of reading a 7070 tape.

The IBM 7070 has a tape file searching feature which permits the user to space tape forward or backward over a specified number of tape segments. Each tape segment is defined by a special character called a tape-segment mark (1401 character A8421). Although the 1401 does not have this automatic feature, the tape segment can be detected in 1401 core storage by using a COMPARE instruction. The 1401 IOCS treats a tape segment mark as a noise record, therefore, it cannot be used with programs using IOCS.

The 1401 word mark, which is written as a word separator character when 1401 WRITE TAPE WITH WORD MARKS instructions are executed, has no special significance to the 7070. Thus, WRITE TAPE instructions should be used in programs that prepare tapes to be used by the 7070. With this operation, word separators are not written on the tape.

	WRITE	READ	WRITE	READ
1401 Core Storage	Even Parity Tape (%Ux)	1401 Core Storage	Odd Parity Tape (%Bx)	1401 Core Storage
C	C A	C	C	C
A	C A	C	C	C
		A	A	A

Figure 88. C- and A-Bit Tape Characteristics

Tape Units

IBM 729 Magnetic Tape Unit

The IBM 1401 can use either of three models of the IBM 729 Magnetic Tape Unit (Model II, Model IV, and Model V). The tape system can accommodate as many as six IBM 729 tape units (Figure 89) which are attached to the tape adapter. The IBM 729 dual-density tape switch makes it possible for the IBM 729 tape unit to operate with magnetic tapes recorded at either 200, 556, or 800 characters-per-inch.

IBM 7330 Magnetic Tape Unit

The IBM 7330 Magnetic Tape Unit (Figure 90) provides the advantages of magnetic tape to IBM 1401 system users whose operations do not demand the high-speed operation of the IBM 729 Magnetic Tape Unit. The 7330 tape unit has dual density. That is, it can read or write tape at character rates of 200 or 556 characters-per-inch. The dual-density feature, the same length inter-record gap ($\frac{3}{4}$ inch), and the same BCD recording make the tapes prepared by the IBM 7330 Magnetic Tape Unit compatible with tapes prepared by the IBM 727 and 729 Magnetic Tape Units and the IBM 7701 and 7702 Magnetic Tape Transmission Terminals. This means magnetic tapes, prepared

in an installation using the IBM 7330, can be read in another installation using IBM 729 tape units.

The 7330 tape unit is housed in two SMS cubes. The tape reels, read-write heads, and tape circuits are in the upper cube. The lower cube contains the tape unit entry and exit connectors.

The processing speed is the primary difference between the IBM 729 and IBM 7330 tape units. Figure 91 shows a comparison of the four tape units available for use with the IBM 1401 Data Processing System. Where speed of tape processing is not a prime concern, but the volume of repetitive information is too cumbersome for efficient unit-record processing, the 7330 tape unit can be used to advantage.

Six 7330 tape units can be accommodated by the tape control unit. The IBM 1401 stored-program addresses for these units is %U1 through %U6.

Tape Intermix

This special feature makes it possible to have 729 II, IV, V and 7330 magnetic tape units in any combination, connected to the same 1401 system at one time. Thus, the tape units best suited for the job to be done can be used. Some jobs may require a pair of high-speed tape units (729 IV's) while the balance of the operation can be performed on a slower unit (7330).

Now, any combination of tape units can be provided to best suit the need of the application. The intermix

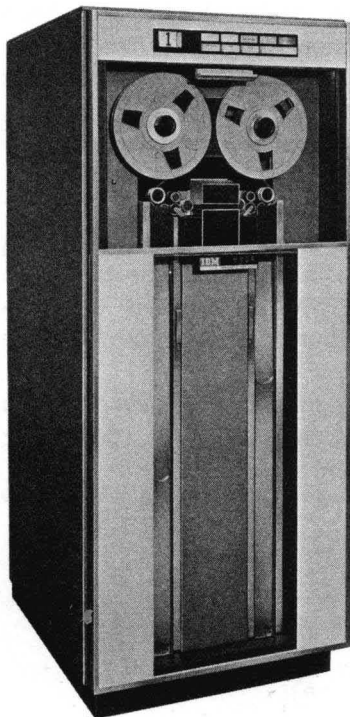

Figure 89. IBM 729 Magnetic Tape Unit



Figure 90. IBM 7330 Magnetic Tape Unit

feature also allows a 1401 with IBM 7330 Magnetic Tape Units to borrow IBM 729 Magnetic Tape Units (IV or V) from another system (such as an IBM 7090 Data Processing System) when a high-speed run is required. The intermix feature greatly increases the flexibility of the IBM 1401 Data Processing System to meet the requirements of any application.

Tape Checking

The IBM 729 and 7330 tape units maintain a high reliability in originating data storage on tape.

The two-gap head, makes it possible to verify automatically the validity of recorded information at the time it is written. The relative positions of the read and write gaps (Figure 92) are such that a character recorded by the write gap passes the corresponding read gap almost instantaneously. Thus, as each character of a record is written, it is read, and a parity check is applied.

If an error is detected, the stored program receives a signal, and corrective action can be taken following the completion of the write operation.

A part of the tape read circuits is used for read checking purposes for both a read and a write operation. There are two, seven-position registers, each of which is sensitized to accept a specified minimum tape output signal.

Figure 93 shows the sensitivity levels, and the relative strength of pulses that are acceptable or not acceptable in read and write operations. The high and low registers accept tape signals equal to, or greater than, the percentages shown in the figure.

In a write operation, the high register is checked for correct parity, to insure adequate signal strength,

OPERATING CHARACTERISTICS	729II	729IV	729V	7330
Density, Characters Per Inch	200 or 556	200 or 556	200 556 or 800	200 or 556
Tape Speed, Inches Per Second	75	112.5	75	36
Inter Record Gap Size, Inches	$\frac{3}{4}$	$\frac{3}{4}$	$\frac{3}{4}$	$\frac{3}{4}$
Character Rate, Characters Per Second	15,000 or 41,667	22,500 or 62,500	15,000 41,667 or 60,000	7,200 or 20,016
High Speed Rewind, Minutes	1.2	.9	1.2	2.2
Regular Rewind, Inches Per Second	75	112.5	75	36

Figure 91. Tape-Unit Characteristics

and then compared, bit by bit, to the low register. If either of these checks detects an error, the tape error indicator is turned ON.

During a read or write operation, the output of each of the high-register bit positions (low register, if the high register is in error) is sent to the longitudinal-redundancy check register (LRCR). This insures that an even number of bits, including check bit, are read in each of the seven tracks on tape. An LRCR error turns ON the tape error indicator.

During a tape read operation, the high register is checked for correct parity. If it is correct, its contents are transferred to the read-write register and to the LRCR. If parity is not correct, the contents of the low register are unconditionally transferred to the read-write register and to the LRCR. In this case, the error in the high register does not turn the tape error indicator ON. Thus, a bit which has a weak signal can be read from tape.

The read-write register is also checked for correct parity. If incorrect parity is found, the tape error indicator is turned ON.

If correct, the contents of the read-write register is sent to core storage. If a tape error is suspected, the tape unit can be backspaced by programming, and the record re-read. If the error persists, the operator can intervene, or the program can branch to an error routine.

Dust or damage to the magnetic tape is the most frequent cause of errors detected during write operations. Such imperfections are usually isolated; so, in order to skip the defective section, the 1401 has been provided with an instruction that causes the tape to space forward approximately 3.5 inches when the next write operation is initiated. While the tape is passed, this short length is erased so that extraneous data are not sensed when the tape is read. The tape-write operation continues after the skip is completed.

Another feature for file protection is a plastic ring (Figure 94) that fits into a groove in the tape reel. The tape can be read with or without this file-protection ring in place, but no writing can be done without it.

The file-protection ring should be removed from a tape reel when writing is completed, thus protecting tape records from accidental writing.

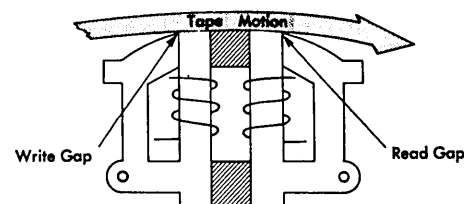

Figure 92. Read and Write Gap

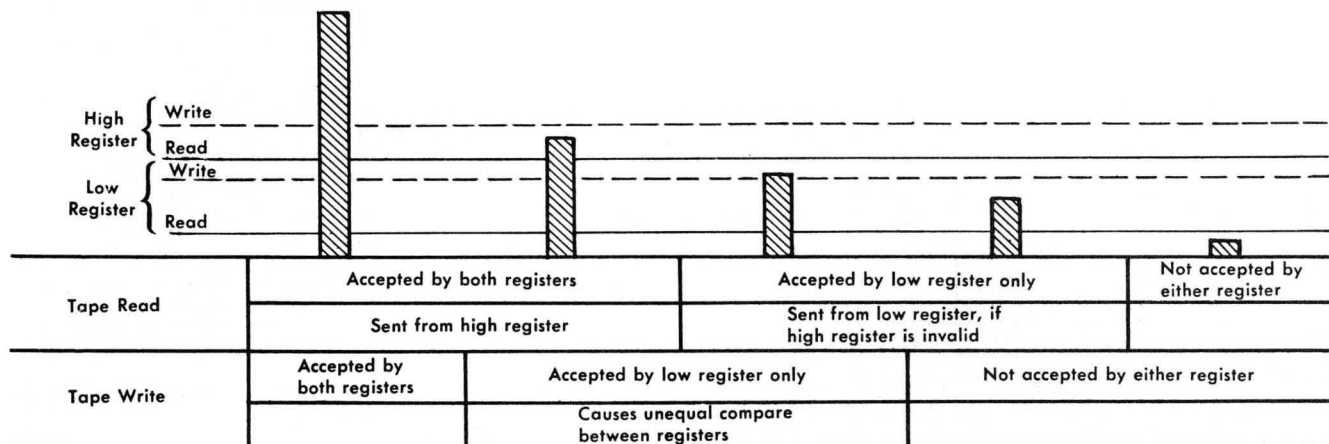

Figure 93. Relative Sensitivity Levels

Magnetic-Tape Operations

IBM 729 Magnetic Tape Unit

If the 729 is in *write* status, to change to *read* status the program must *backspace* over those records that are to be read. The tape unit must then be changed back to *write* status ($W_1, W_2, W_3, B_3, B_2, R_2, R_3, W_4, W \dots$). This results in unchecked tape on the first record written after *backspace*.

The 729 cannot be switched directly from write to read status (W_1, W_2, R_3, R_4).

If the 729 is in *read* status, the tape unit can be changed directly from read to write status (R_1, R_2, W_3, W_4).

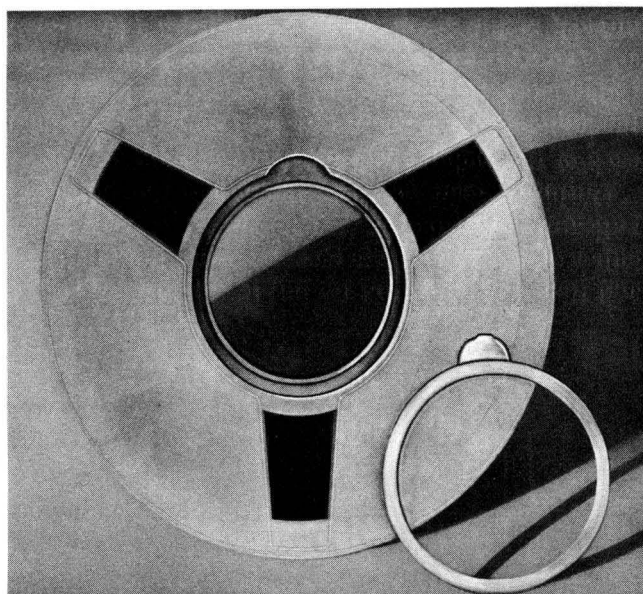

Figure 94. File-Protection Ring

IBM 7330 Magnetic Tape Unit

If the 7330 is in *write* status, to change to *read* status the program must *backspace* over those records that are to be read. The tape unit must then be changed back to *write* status ($W_1, W_2, W_3, B_3, B_2, R_2, R_3, W_4, W \dots$). This results in unchecked tape on the first record written after *backspace*.

The 7330 cannot be switched directly from write to read status (W_1, W_2, R_3, R_4).

If the 7330 is in *read* status, to change to *write* status the program must *backspace* over the last record read and then rewrite that record. The 7330 then continues in write status ($R_1, R_2, B_2, W_2, W_3, W \dots$).

The 7330 cannot be switched directly from read to write status (R_1, R_2, W_3, W_4).

Figure 95 is a summary of 1401 magnetic-tape operations.

For detailed information concerning magnetic tape and IBM magnetic tape units, refer to the IBM Reference Manual, *Magnetic Tape Units*, form A22-6589.

Tape Instructions

Read Tape

Instruction Format.

Mnemonic	Op Code	A-address	B-address	d-character
SPS MU	<u>M</u>	%Ux	xxx	R
A RT				

Function. The tape unit specified in the A-address is started. The d-character specifies a tape read operation. The B-address specifies the high-order position of the tape read-in area of storage. The machine begins to read magnetic tape, and continues to read until either an inter-record gap in the tape record

STATUS	OPERATION	729	CAN BE PERFORMED		
			REMARKS	7330	REMARKS
Read	R ₁ B ₁ W ₁ W ₂ W----	Yes	Updating tape label	Yes	Updating tape label
	R ₁ R ₂ Skip W ₃ W----	Yes	Results in unchecked tape	Yes	Results in unchecked tape Skip must be over known blank area
	R ₁ R ₂ W ₃ W----	Yes	Unchecked tape in record W ₃	No	Write head is over first part of next record (W ₃)
	R ₁ B ₁ W ₁ R ₂	No	Changing from W to R causes bits in the inter-record gap	No	Changing from W to R causes bits in the inter-record gap
Write	W ₁ B ₁ R ₁ W ₂ W----	Yes	Unchecked tape on record W ₂	Yes	Unchecked tape on record W ₂
	W ₁ W ₂ Blank Area R ₃ R----	Not Recom.	Results in bits in the inter-record gap and possible error on R ₃	Not Recom.	Results in bits in the inter-record gap and possible error on R ₃
	W ₁ W ₂ R ₃ R ₁	No	Changing from W to R causes bits in the inter-record gap	No	Changing from W to R causes bits in the inter-record gap
	W ₁ B ₁ R ₁ R ₂	No	Changing from W to R causes bits in the inter-record gap	No	Changing from W to R causes bits in the inter-record gap
Rewind	R ₃ R ₄ R ₅ R _w	Yes		Yes	
	W ₃ W ₄ W ₅ R _w	Yes	Causes extraneous bits after W ₅ (label)	Yes	Causes extraneous bits after W ₅ (label)

R —read
W —write
B —backspace
R_w—rewind

Figure 95. Summary of IBM 1401 Magnetic-Tape Operations

or a group-mark with a word-mark in core storage is sensed. The inter-record gap indicates the end of the tape record and a group-mark (code CBA 8421) is inserted in 1401 core storage at this point.

If the group-mark with a word-mark occurs before the inter-record gap is sensed, the transfer of data from tape stops but tape movement continues until the inter-record gap is sensed.

Word Marks. Word marks are not affected.

Timing. $T = .0115 (L_I + 1) \text{ ms} + T_M$. Time varies for type of tape unit and tape density used (see *Timing* section).

Address Registers After Operation.

I-Add. Reg. A-Add. Reg. B-Add. Reg.
NSI %4x Group-mark +1

Example. Read the record from tape unit 2 (labeled 2) to 1401 core storage. The high-order tape-record character is moved to INPUT (0419), the next character is moved to the next higher position (0420), etc., until transfer of data is stopped by an inter-record gap in the tape record, or a group-mark with a word-mark in 1401 core storage (Figure 96).

SPS											
LINE	COUNT	LABEL	OPERATION	(A) OPERAND				(B) OPERAND			
				ADDRESS	CHAR. ADJ.	CHAR. ADJ.	ADDRESS	CHAR. ADJ.	CHAR. ADJ.	ADDRESS	
3	0	2	MU	2021				0419			R
9	1	0									

Autocoder											
Label	Operation	OPERAND									
9	15	20	25	30	35	40	45	50	55	60	65
RT		R ₂ INPUT									

Assembled Instruction: M %U2 419 R

Figure 96. Tape Read (Move)

Write Tape

Instruction Format.

Mnemonic	Op Code	A-address	B-address	d-character
SPS MU	<u>M</u>	%Ux	xxx	W
A WT				

Function. The tape unit designated in the A-address is started. The d-character specifies a tape write operation. The data from core storage is written on the tape record. The B-address specifies the high-order position of the record in storage. A group-mark with

a word-mark in 1401 core storage stops the operation. The group-mark with a word-mark causes an inter-record gap to be created.

Word Marks. Word marks are not affected.

Timing. $T = .0115 (L_I + 1) \text{ ms} + T_M$.

Note. If a group-mark with a word-mark is the first character of B-address, the tape-adaptor unit and the tape unit will hang up. The condition can be reset by pressing the start-reset key if the tape-select switch (on the 1401) is in the N (normal) position.

Address Registers After Operation.

I-Add. Reg. A-Add. Reg. B-Add. Reg.
 NSI %4x Group-mark +1

Example. Transfer the contents of core storage to tape unit 3 (labeled 3), starting at the location labeled OUTPUT (0525) and ending at the location of the first group-mark with a word-mark (Figure 97).

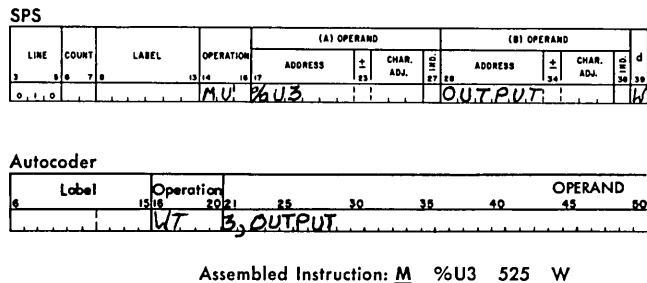

Figure 97. Tape Write (Move)

Read Tape with Word Marks

Instruction Format.

Mnemonic Op Code A-address B-address d-character
 SPS LU L %Ux xxx R
 A RTW

Function. This is the same as the READ TAPE operation, except that word separator characters on magnetic tape (written during WRITE TAPE WITH WORD MARKS instruction) are translated to word marks during transmission to 1401 core storage.

Word Marks. A word-separator character read from tape causes a word mark to be associated with the next tape character transferred to 1401 core storage (Figure 98).

Timing. $T = .0115 (L_I + 1) \text{ ms} + T_M$.

Tape Positions	A	B	C	D
Tape Code	82	A841	41	C4
1401 Core Storage Locations	A	B	C	
1401 Meaning	0	5	4	
1401 Core Storage Code	C82	41W	4	

Figure 98. Word-Separator Character (Tape Read)

Note. If a record has been written on tape by a WRITE TAPE WITH WORD MARKS instruction, it should be read back by a READ TAPE WITH WORD MARKS instruction so that word-separator characters will be translated to word marks.

Address Registers After Operation.

I-Add. Reg. A-Add. Reg. B-Add. Reg.
 NSI %4x Group-mark +1

Example. Read the record from tape unit 5 (labeled 5) to 1401 core storage, and insert word marks where word-separator characters exist in the tape record. The high-order character is moved to INREC1 (0518), the next character is moved to the next higher position (0519), etc., until the transfer of data is stopped by an inter-record gap in the tape record, or until a group-mark with a word-mark is sensed in 1401 core storage (Figure 99).

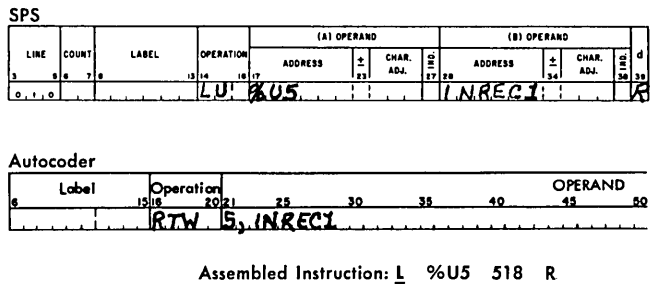

Figure 99. Tape Read (Load)

Write Tape with Word Marks

Instruction Format.

Mnemonic Op Code A-address B-address d-character
 SPS LU L %Ux xxx W
 A WTW

Function. This is the same as the WRITE TAPE operation except that the WRITE TAPE WITH WORD MARKS instruction affects word marks in core storage.

Word Marks. A word mark associated with any position in 1401 storage causes a word-separator character (A841) to be written automatically on tape, one character ahead of that which contained the word mark. Thus, word marks are translated to word-separator characters for tape storage (Figure 100).

1401 Core Storage				
Locations	A	B	C	
1401 Core Storage				
Code	C82	41W	4	
1401 Meaning	0	5	4	
Tape Positions	A	B	C	D
Tape Code	82	A841	41	C4

Figure 100. Word-Separator Character (Tape Write)

Timing. $T = .0115 (L_I + 1) \text{ ms} + T_M$.

Note. Load operations must be used when word marks are needed for identification in tape storage. If tape is written by a WRITE TAPE WITH WORD MARKS instruction, it must be read back by a READ TAPE WITH WORD MARKS instruction to insure proper translation between the tape and 1401 core storage.

Address Registers After Operation.

I-Add. Reg.	A-Add. Reg.	B-Add. Reg.
NSI	%4x	Group-mark +1

Example. Transfer the contents of core storage to tape unit 6 (labeled 6). Insert a word-separator character where word marks exist in core storage, beginning at OUTREC (0696) and ending at the first group-mark with a word-mark in 1401 core storage (Figure 101).

SPS

LINE	COUNT	LABEL	OPERATION	(A) OPERAND				(B) OPERAND				d
				ADDRESS	±	CHAR. ADJ.	±	ADDRESS	±	CHAR. ADJ.	±	
3	0 8 7 0		CU	0696				0696				6
0	1 0											

Autocoder

Label	Operation	OPERAND					
BSP	CU	25	30	35	40	45	50
RTW 6, OUTREC							

Assembled Instruction: L %U6 696 W

Figure 101. Tape Write (Load)

Backspace Tape Record

Instruction Format.

Mnemonic	Op Code	A-address	d-character
SPS CU	<u>U</u>	%Ux	B
A BSP			

Function. The tape unit specified in the A-address backspaces over one tape record. The first inter-record gap (IRG) encountered stops the backspace operation specified by the d-character, B.

Word Marks. Word marks are not affected.

Timing. $T = .0115 (L_I + 1) \text{ ms} + T_M$.

Address Registers After Operation.

I-Add. Reg.	A-Add. Reg.	B-Add. Reg.
NSI	%4x	dbb

Example. Backspace tape unit 4 (labeled 4) until an IRG is sensed (Figure 102).

SPS

LINE	COUNT	LABEL	OPERATION	(A) OPERAND				(B) OPERAND				d
				ADDRESS	±	CHAR. ADJ.	±	ADDRESS	±	CHAR. ADJ.	±	
3	0 8 7 0		CU	0696								6
0	1 0											

Autocoder

Label	Operation	OPERAND					
BSP	CU	25	30	35	40	45	50
Assembled Instruction: <u>U</u> %U4 B							

Figure 102. Backspace Tape

Write Tape Mark

Instruction Format.

Mnemonic	Op Code	A-address	d-character
SPS CU	<u>U</u>	%Ux	M
A WTM			

Function. This instruction causes a tape mark character (8421) to be recorded immediately following the last record on tape. When the tape mark is read back from a tape, the end-of-reel indicator is turned on. This signals the 1401 program that the end of a major group of records has been reached (end-of-file) or the end of utilized tape has been reached.

Word Marks. Word marks are not affected.

Timing. $T = .0115 (L_I + 1) \text{ ms} + T_M$.

Address Registers After Operation.

I-Add. Reg.	A-Add. Reg.	B-Add. Reg.
NSI	%4x	dbb

Example. Insert a tape mark on the tape in tape unit 3 (labeled 3), Figure 103.

SPS

LINE	COUNT	LABEL	OPERATION	(A) OPERAND				(B) OPERAND				d
				ADDRESS	±	CHAR. ADJ.	±	ADDRESS	±	CHAR. ADJ.	±	
3	0 8 7 0		CU	0696								6
0	1 0											

Autocoder

Label	Operation	OPERAND					
WTM	CU	25	30	35	40	45	50
Assembled Instruction: <u>U</u> %U3 M							

Figure 103. Write Tape Mark

Skip and Blank Tape

Instruction Format.

Mnemonic	Op Code	A-address	d-character
SPS CU	<u>U</u>	%Ux	E
A SKP			

Function. The tape unit, designated by the A-address, spaces forward and erases approximately 3.5 inches of tape. The actual skip occurs when the next WRITE TAPE instruction is given. This instruction makes it possible to bypass defective tape areas.

Word Marks. Word marks are not affected.

Timing. $T = .0115 (L_I + 1)$ ms. Processing can continue immediately after this operation. However, 40.5 ms for IBM 729 II, 27 ms for IBM 729 IV and 108 ms for an IBM 7330 must be added to the next WRITE TAPE instruction time.

Note. The SKIP AND BLANK TAPE instruction should be given immediately preceding a WRITE TAPE instruction for the tape unit specified by both instructions.

Address Registers After Operation.

I-Add. Reg.	A-Add. Reg.	B-Add. Reg.
NSI	%4x	dbb

Example. Erase tape on tape unit 5 (labeled 5) when the next write operation is ordered for that unit (Figure 104).

SPS													
LINE	COUNT	LABEL	OPERATION	(A) OPERAND				(B) OPERAND				d	
				ADDRESS	Z	CHAR. ADJ.	27	ADDRESS	Z	CHAR. ADJ.	27		
5	8	7	8	CU	%U5								E

Autocoder												
6	Label		Operation		OPERAND							
	15	18	20	21	25	30	35	40	45	50		
			SKP	5								

Assembled Instruction: U %U5 E

Figure 104. Erase Forward

Rewind Tape

Instruction Format.

Mnemonic	Op Code	A-address	d-character
SPS CU	<u>U</u>	%Ux	R
A RWD			

Function. This instruction is usually given after an end-of-reel condition, and causes the selected tape unit to rewind its tape. When the operation is initiated, the tape unit is, in effect, disconnected from the system.

Word Marks. Word marks are not affected.

Timing. $T = .0115 (L_I + 1)$ ms. Rewind time is 1.2 minutes per 2,400-foot reel for the IBM 729 II, .9 minute for the IBM 729 IV, and 13.3 minutes for the IBM 7330, but it is not calculated with program time. Processing can continue approximately 10 ms after this instruction is interpreted.

Address Registers After Operation

I-Add. Reg.	A-Add. Reg.	B-Add. Reg.
NSI	%4x	dbb

Example. Rewind the tape in tape unit 1 (labeled 1), Figure 105.

SPS													
LINE	COUNT	LABEL	OPERATION	(A) OPERAND				(B) OPERAND				d	
				ADDRESS	Z	CHAR. ADJ.	27	ADDRESS	Z	CHAR. ADJ.	27		
5	8	7	8	RWD	%U1								R

Autocoder												
6	Label		Operation		OPERAND							
	15	18	20	21	25	30	35	40	45	50		
			RWD	1								

Assembled Instruction: U %U1 R

Figure 105. Rewind Tape

Rewind Tape and Unload

Instruction Format.

Mnemonic	Op Code	A-address	d-character
SPS CU	<u>U</u>	%Ux	U
A RWU			

Function. This instruction causes the tape unit specified in the A-address to rewind its tape. At the end of the rewind, the tape is out of the vacuum columns, and the reading mechanism is disengaged. The unit is effectively disconnected from the system, and is not available again until the operator restores it to a ready status.

Word Marks. Word marks are not affected.

Timing. $T = .0115 (L_I + 1)$ ms. Rewind time is 1.2 minutes per 2,400-foot reel for the IBM 729 II, .9 minute for the IBM 729 IV, and 2.2 minutes for the IBM 7330, but it is not calculated with program time.

Processing can continue approximately 10 ms after this instruction is interpreted by a system using IBM 729 tape units, or 4.5 ms in a system using IBM 7330 tape units.

Address Registers After Operation.

I-Add. Reg.	A-Add. Reg.	B-Add. Reg.
NSI	%4x	dbb

Example. Rewind the tape in tape unit 5 (labeled 5), and make it unavailable to the stored program, at the completion of the rewind operation (Figure 106).

SPS																
LINE	COUNT	LABEL	OPERATION	(A) OPERAND				(B) OPERAND								
				ADDRESS	±	CHAR. ADJ.	IND.	ADDRESS	±	CHAR. ADJ.	IND.					
3	8	7	8	13	14	16	17	23	24	27	28	34	35	38	39	d
0	1	0		C	U	%	U	5								U

Autocoder									
Label	Operation	OPERAND							
5	15/16	20/21	25	30	35	40	45	50	55
	R	W	U	5					

Assembled Instruction: U %U5 U

Figure 106. Rewind and Unload

Branch if End of Reel

Instruction Format.

Mnemonic	Op Code	I-address	d-character
SPS B	<u>B</u>	xxx	K
A BEF			

Function. The end-of-reel indicator (EOR) turns on in the IBM 1401 Processing Unit if a tape mark is read by the 1401, or if a *reflective spot* is sensed during a write tape operation. This instruction tests the indicator and causes an automatic branch to the I-address if the indicator is ON. If it is OFF, the program continues normally.

Word Marks. Word marks are not affected.

Timing. $T = .0115 (L_I + 1)$ ms.

Note. This instruction must be executed immediately following a tape read or tape write operation to insure correct results. The EOR indicator cannot be tested if another tape unit is selected.

Address Registers After Operation.

I-Add. Reg.	A-Add. Reg.	B-Add. Reg.
NSI	BI	dbb

Example. Test the tape unit just used for an end-of-reel condition. If there is an EOR condition, branch to TAPER1 (0685) for the next instruction. If no EOR exists, continue the program with the next sequential instruction (Figure 107).

SPS																
LINE	COUNT	LABEL	OPERATION	(A) OPERAND				(B) OPERAND								
				ADDRESS	±	CHAR. ADJ.	IND.	ADDRESS	±	CHAR. ADJ.	IND.					
3	8	7	8	13	14	16	17	23	24	27	28	34	35	38	39	d
0	1	0		B		T	A	P	E	R	1					K

Autocoder									
Label	Operation	OPERAND							
5	15/16	20/21	25	30	35	40	45	50	55
	B	E	F	T	A	P	E	R	1

Assembled Instruction: B 685 K

Figure 107. Test for End of Reel

Branch if Tape Error

Instruction Format.

Mnemonic	Op Code	I-address	d-character
SPS B	<u>B</u>	xxx	L
A BER			

Function. If an error occurs in transmission between a tape unit and the 1401 during a tape read or tape write operation, an error indicator turns on in the 1401 and the tape light on the console glows red. This instruction tests the error indicator, and branches to the I-address for the next instruction if the indicator is ON. If it is OFF, the program continues with the next sequential instruction.

Word Marks. Word marks are not affected.

Timing. $T = .0115 (L_I + 1)$ ms.

Notes. The BRANCH IF TAPE ERROR instruction must be given after a tape read or write operation, because any tape operation on any tape unit causes the indicator to turn off. The information read from tape always enters core storage with odd-bit parity. Therefore, the tape read-in area need not be cleared after a tape read error has occurred. See *Tape Select Switch in Operating Features* section.

Address Registers After Operation.

I-Add. Reg.	A-Add. Reg.	B-Add. Reg.
NSI	BI	dbb

Example. Read a tape record from the tape unit 3 (labeled 3) into core-storage area labeled TAPEIN (0629) and test for a tape error. If there is an error, branch to TAPER2 (0539) for the next instruction. If there is no error, continue processing with the next sequential instruction (Figure 108).

SPS																
LINE	COUNT	LABEL	OPERATION	(A) OPERAND				(B) OPERAND								
				ADDRESS	±	CHAR. ADJ.	IND.	ADDRESS	±	CHAR. ADJ.	IND.					
3	8	7	8	13	14	16	17	23	24	27	28	34	35	38	39	d
0	1	0		M	U	%	U	3		T	A	P	E	I	N	R
0	2	0		B		T	A	P	E	R	2					L

Autocoder										
Label	Operation	OPERAND								
5	15/16	20/21	25	30	35	40	45	50	55	
	R	T		3	T	A	P	E	I	N
	B	E	R	T	A	P	E	R	2	

Assembled Instruction: M %U3 629 R
B 539 L

Figure 108. Test for Transmission Error

The IBM 1405 Disk Storage unit (Figure 109) combines the data processing capabilities of the IBM 1401 Data Processing System with the advantages and facility of large-capacity random access storage. The combination of the 1401 and 1405 provides an efficient and economical in-line data processing system.

The in-line method of data processing continually maintains the records of a business in an up-to-date status. Any transaction affecting a business can be processed when it occurs, and all records and accounts affected are updated immediately. The executives of an organization have available, at any time, information representing the status of any account at that moment.

Records in the IBM 1405 Disk Storage unit are stored on the faces of magnetic disks. The 1405 Model 1 has a storage capacity of 10 million alphanumerical characters of information on 25 disks. Model 2 has a storage capacity of 20 million alphanumerical characters on 50 disks.

The Model 2 disk storage unit is divided into two modules. Each module contains 50,000 records on 25

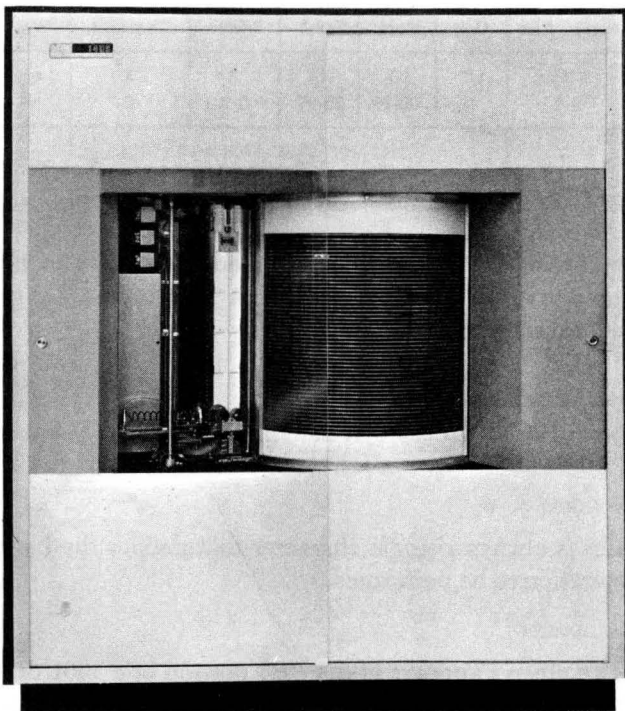

Figure 109. IBM 1405 Disk Storage Unit

disks. Each disk face has 200 tracks which are subdivided into 5 sectors. Each sector can contain a 200-character record (Figure 110).

Access Arms

The disk storage unit can have two access arms. One is standard and the other is available as a special feature. The fork-shaped access arm has two read-write heads that read and record data in the unit. One read-write head is for the top disk-surface; the other is for the bottom disk-surface. During a seek operation, the access mechanism moves vertically to seek a disk, and horizontally to seek a track (Figure 111).

To execute a read, write, or write check command, the access arm must previously have been directed to the proper track location by a seek command.

Speed

The disks rotate on a vertical shaft at the rate of 1200 revolutions per minute. Data is read or recorded at the rate of 22,500 characters per second. Access time is 100 milliseconds, minimum, and 800 milliseconds for Model 2 (700 milliseconds for Model 1), maximum. Access time is the time required to locate a particular disk track. Read, write, and write check operations can be performed on a disk record without having to reseek if no other seek operation intervenes.

Coding

~~The magnetic-disk recording code is the same binary-coded-decimal used in the IBM 1401 Processing Unit. Data is recorded in seven-bit codes (serially by bit) on the disk.~~

To insure the accuracy of recorded data, a parity check is made while data is transferred from disk storage to core storage during a read or write operation. A programmed WRITE DISK CHECK is made to compare data written on the disk with the data in core storage.

Disk Storage Addressing

Each sector has an indelible 7-digit record address preceding the 200-character record area (Figure 112). The disk records are arranged sequentially in ascending order from bottom to top of the disk storage unit. The record address of the first record in the outside track of the bottom disk is x0000000. The address of the last record in the inside track of the top disk is

Page 63 — Coding, replace first paragraph with:

The magnetic-disk recording code is the same binary-coded-decimal used in the IBM 1401 Processing Unit. Data is recorded serially by bit in 7-bit code (CBA 8421) when operating in the Move mode, and in 8-bit code (CBA 8421 M) when operating in the Load mode. The eighth bit, which is used when operating in the Load mode is for a possible word mark (M) with the character being written on, or read from, the disk record.

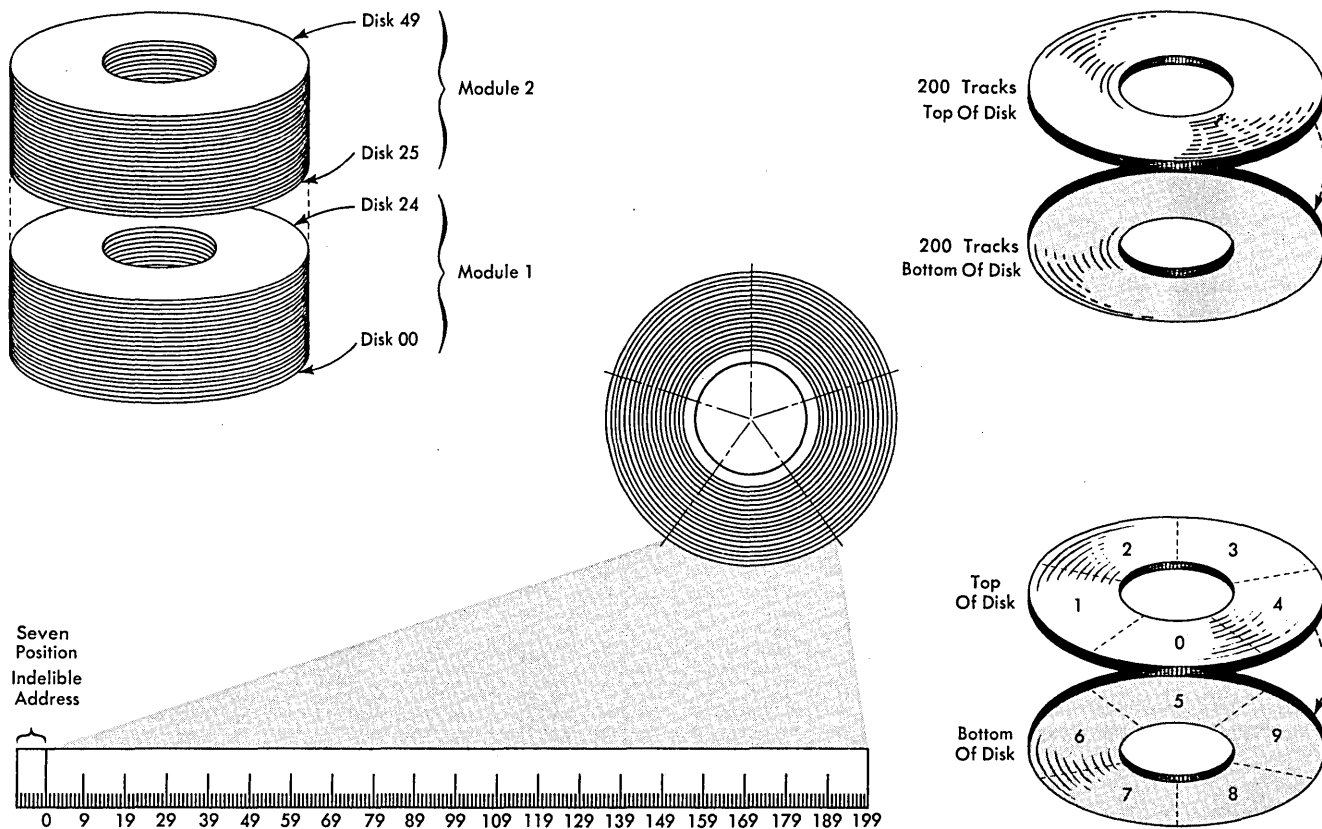

Figure 110. Disk Storage

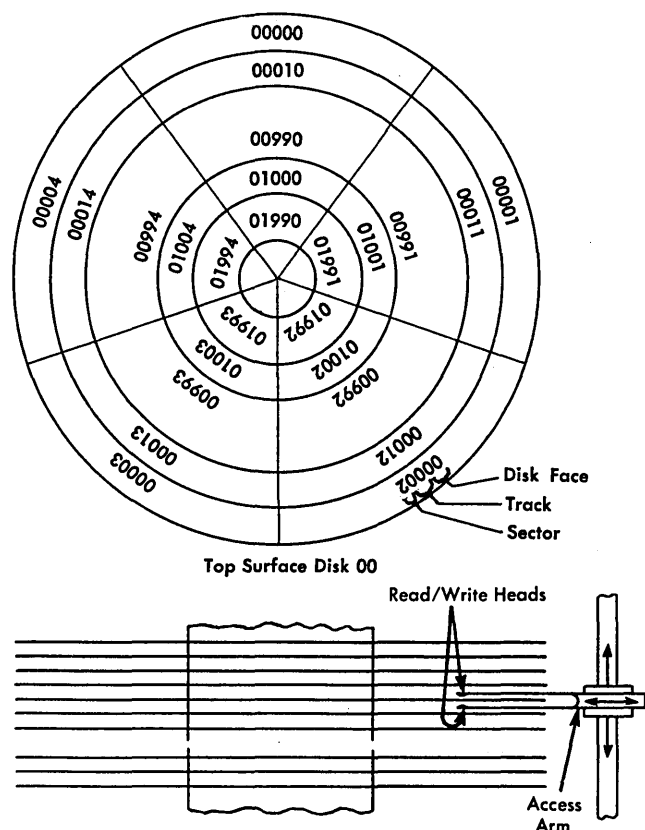

Figure 111. Access Arm

IN 1401 CORE STORAGE						
Access Arm	Unit	Disk Face	Track	Sector	Constant	GM WM
X	X	XX	XX	X	X	≠
0-1	0	00-99	00-99	0-9	0	—
ON 1405 DISK STORAGE						

Figure 112. Record Address Format

x0999990. The “x” in the record address refers to the access arm to be used and is not part of the 7-digit indelible address.

Instruction Format

<i>Mnemonic</i>	<i>Op Code</i>	<i>A-address</i>	<i>B-address</i>	<i>d-character</i>
X	<u>X</u>	%FX	XXX	X

OP CODE

This is always a single character that defines the basic operation to be performed.

A-ADDRESS

%Fx always appears in the (A) portion of a 1401 disk storage instruction. The %F signals that the disk unit is to be selected and the x represents the digit used to perform various operations:

<u>X-Position</u>	<u>Operation</u>
0	Seek a disk record.
1	<i>Single record</i> – Reading or writing of 200 characters is stopped when a group-mark with a word-mark, or the end of a sector, is sensed. If a group-mark with a word-mark is sensed before completing the reading of the sector of the track, reading stops and the wrong-length record-indicator turns ON.
2	<i>Full track</i> – An entire track is read or written (5 sectors of 200 characters each). Reading or writing of the full track begins at the sector addressed and continues for four additional sectors. If a group-mark with a word-mark is sensed before completing the reading of the last sector of the track, reading stops and the wrong-length record indicator turns ON.
3	<i>Write Check</i> – Data written on a disk in a preceding write operation is read from the disk and compared, character-by-character, with the data in core storage. A write check can be given following a single record or full-track operation.

B-ADDRESS

The B-address specifies the high-order position in core storage of the eight-digit record address. The record address must be followed by a group-mark with a word-mark and the area of core storage from which data is to be read into or out of by the disk storage unit. The data area must be followed by a group-mark with a word-mark.

d-CHARACTER

The d-character is used to specify the operation to be performed.

IBM 1405 Disk Storage Instructions

Seek Disk

Instruction Format.

Mnemonic	Op Code	A-address	B-address	d-character
SPS MU or LU	<u>M</u> or <u>L</u>	%F0	xxx	R
A	SD			

Function. The A-address specifies that a seek operation is to be performed by the access arm. The B-address specifies the high-order position in core storage of the disk record address which is followed by a group-mark with a word-mark.

The selected access arm seeks the disk and track specified in the disk record address. Processing can continue while the access arm is in motion.

Word Marks. Word marks are not affected.

Timing. T = .0115 (L₁ + 9) ms + access time.

Note. If the access arm is already at the disk track that is to be used, a SEEK DISK instruction need not be given.

Address Registers After Operation.

I-Add. Reg.	A-Add. Reg.	B-Add. Reg.
NSI	B + 1	B + 8

Example. Seek record 050090 with access arm 1. Storage locations 0590-0597 (labeled INPUTA) contain 10500900 (Figure 113).

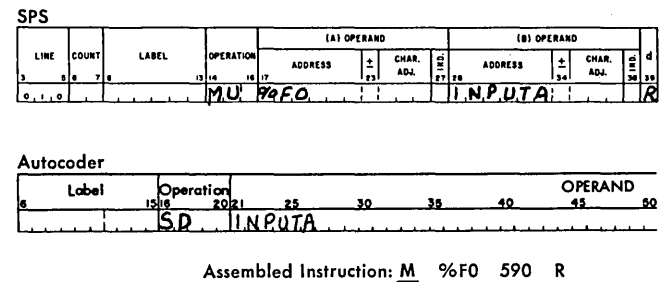

Figure 113. Seek Instruction

**Read Disk Single-Record
Read Disk Full-Track**

Instruction Format.

Mnemonic	Op Code	A-address	B-address	d-character
SPS MU	<u>M</u>	%Fx	xxx	R
A	RD (single record)			
	RDT (full track)			

Function. This instruction causes data to be read from disk storage into core storage. The digit 1 in the A-address (%F 1) specifies that a single record is to be read. The reading of the disk is stopped by a group-mark with a word-mark in core storage and the end of the sector. If the digit 2 is present in the A-address (%F 2) a full-track read occurs. That is, five 200-character records are read from disk storage into core storage. Reading stops at the end of the fifth sector.

The B-address specifies the high-order position in core storage of the disk-record address which is followed by a group-mark with a word-mark, and the area in storage reserved for the data read from the disk.

The R in the d-character position signifies that this is a read operation.

Word Marks. A group-mark with a word-mark must appear one position to the right of the record address and one position to the right of the last position reserved in core storage for the disk record. If

a group-mark with a word-mark is detected before reading of the record is completed, the wrong-length record indicator turns ON and reading stops.

Timing.

$T = .0115 (L_r + 9) + 10 \text{ ms} + \text{disk rotation}.$
 60.196 ms is maximum time for single-record read.
 10.196 ms is minimum time for a single-record read.

Note: Before reading starts, an automatic check of the record address in storage with the record address on the disk is made. If they are not the same, the unequal address compare indicator turns ON, and the data on the disk cannot be read into storage.

Address Registers After Operation.

I-Add. Reg. NSI	A-Add. Reg. B + 1	B-Add. Reg. B + 210 or B + 1010
--------------------	----------------------	--

Example. Read a single record from disk storage to core storage, beginning at location 0599 (area is labeled INPUTA). The high-order position of the disk address is in the first eight positions of the label (0590-0597), Figure 114.

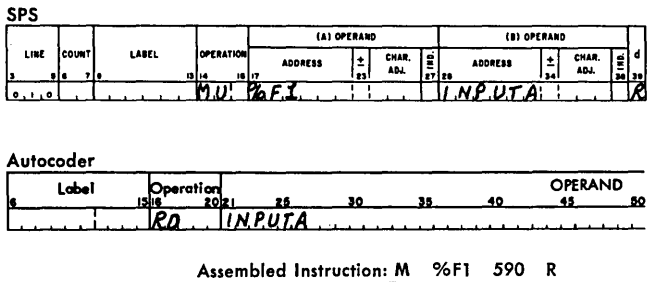

Figure 114. Read a Record

**Write Disk Single-Record
 Write Disk Full-Track**

Instruction Format.

Mnemonic	Op Code	A-address	B-address	d-character
SPS MU	<u>M</u>	%Fx	xxx	W
A	WD (single record)			
	WDT (full track)			

Function. This instruction causes a single record (or full-track characters) in core storage to be written on a disk record. The digit 1 in the A-address (%F 1) specifies that a single record is to be written. If a 2 is present in the A-address (%F 2), five 200-character records are written on a disk track. Writing stops at the end of the fifth sector.

The B-address specifies the high-order position of the disk-record address and is followed by the data to be written on the disk.

The W in the d-character position signifies that this is a write operation.

Word Marks. The writing of data stops when the end of a record is reached on the disk and a group-mark with a word-mark is sensed in core storage. If the group-mark with a word-mark is sensed before the end of a record, the remainder of the disk record is filled with data from core storage and the wrong-length record indicator turns ON. A group-mark with word-mark must be one position to the right of the record address.

Timing.

$T = .0115 (L_r + 9) + 10 \text{ ms} + \text{rotation time}.$
 60.196 ms is maximum time for a single-record write.
 10.196 ms is minimum time for a single-record write.

Note: Before writing starts, an automatic check of the record address in storage, with the record address on the disk, is made. If they are not the same the unequal-address compare indicator turns ON, and the data in storage cannot be written on the disk.

A WRITE DISK CHECK instruction must be performed following a write disk operation. No other disk-storage operation can be performed until the check of data written on the disk is accomplished.

If the data in core storage contains characters with word marks, only the CBA 8421 portion of the character is written on the disk (the word mark is ignored).

Address Registers After Operation.

I-Add. Reg. NSI	A-Add. Reg. B + 1	B-Add. Reg. B + 210 or B + 1010
--------------------	----------------------	--

Example. Write a disk record (single) from the data in area labeled INPUTA (first position of data is at 0599). The high-order position of the disk address is in the first eight positions of the label (0590-0597), Figure 115.

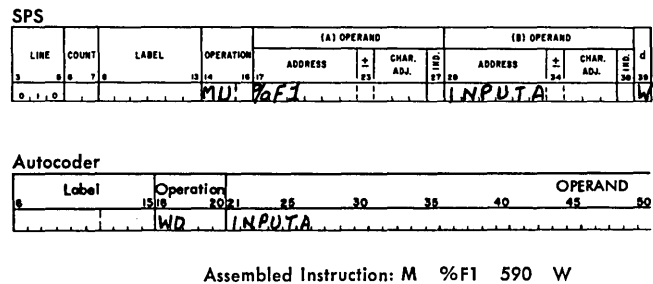

Figure 115. Write a Record

Write Disk Single-Record with Word Marks
Write Disk Full-Track with Word Marks

Instruction Format.

Mnemonic	Op Code	A-address	B-address	d-character
SPS LU	<u>L</u>	%Fx	xxx	W
A	WDW (single record)			
	WDTW (full track)			

Function. This instruction is similar to the write disk operation, except that word marks present in the data in core storage are recorded on the disk record. The mode of operation permits the writing of programs on disk records for systems use. One hundred and seventy-six positions of data with word marks are recorded on the disk during a write single-record operation, and 880 positions are recorded during a write full-track operation.

Word Marks. A group-mark with a word-mark one position to the right of the last character of the record in core storage terminates the write operation. If the group-mark with a word-mark is not in the correct position, the wrong-length record indicator turns ON. A group-mark with a word-mark must be one position to the right of the record address.

Timing. $T = .0115 (L_I + 9) \text{ ms} + 10 \text{ ms} + \text{disk rotation.}$

Note. The programmer should be certain that all records on a specific track are written in the same mode (either by a MOVE or by a LOAD instruction), otherwise, full-track operations are not possible. A write-disk check operation must be performed following this instruction.

Before writing starts, an automatic check of the record address in storage, with the record address on the disk, is made. If they are not the same, the unequal-address compare indicator turns ON, and the data in storage cannot be written on the disk.

Address Registers After Operation.

I-Add. Reg.	A-Add. Reg.	B-Add. Reg.
NSI	B + 1	B + 186
		OR
		B + 890

SPS		(A) OPERAND						(B) OPERAND					
LINE	COUNT	LABEL	OPERATION	ADDRESS	CHAR. ADJ.	CHAR. ADJ.	ADDRESS	CHAR. ADJ.	CHAR. ADJ.	ADDRESS	CHAR. ADJ.	d	
5	0	7	0	13	14	15	17	18	19	20	21	22	23
0	0		LU	%F1						OUTPUT			

Autocoder									
Label	Operation	ADDRESS	CHAR. ADJ.	CHAR. ADJ.	ADDRESS	CHAR. ADJ.	CHAR. ADJ.	ADDRESS	d
5	0	13	14	15	17	18	19	20	21
	LU	%F1						OUTPUT	

Assembled Instruction: L %F1 590 W

Figure 118. Write a Record with Word Marks

Example. Write a disk record with word marks from the area labeled OUTPUT (the first position of data is 0599). The high-order position of the disk address is in the first eight positions of the label (0590-0597), Figure 118.

Branch if Indicator On

Instruction Format.

Mnemonic	Op Code	I-address	d-character
SPS B	<u>B</u>	xxx	x
A	BIN		

Function. The d-character specifies the indicator tested. If the indicator is ON, the next instruction is taken from the I-address. If the indicator is OFF, the next sequential instruction is taken. Figure 119 shows symbols that are valid d-characters and the indicators they test.

The next disk storage operation turns OFF the access-inoperable indicator. The other disk unit indicators are turned OFF by any disk operation except SEEK DISK.

d-CHARACTER	INDICATOR
N	Access Inoperable
V	Read- or Write Parity Check or Read-Back Check Error
W	Wrong-Length Record
X	Unequal-Address Compare
Y	Any Disk-Unit Error Condition

Figure 119. IBM 1405 Branch Instruction d-Character

Indicators. Access Inoperable—An access arm becomes inoperable if the logic safety circuit detects improper operation. A customer engineer can also render an arm inoperable. In either instance, this indicator turns ON when the program addresses the inoperable arm. At the same time, the appropriate access light (1405) and the RAMAC light (1401) turn ON.

The indicator also turns on if an invalid (not installed) arm or disk storage unit is addressed. Because the program continues in sequence, even when an inoperable arm is addressed, a BRANCH IF INDICATOR ON instruction should follow a seek instruction.

Read- or Write-Parity Check or Read-Back Check Error—This indicator turns ON if even-bit parity occurs when reading the record address and information from, or writing information on a disk. Another condition that turns the indicator ON is an unequal compare during a write check operation.

Wrong-Length Record—This indicator turns ON if the number of characters read to, or written on, the disk record is not equal to 200 or 1,000 characters (for M operation code) or 176 or 880 characters (for L operation code).

Unequal-Address Compare—This indicator turns ON if an unequal condition occurs during the automatic checking of the record address in storage with the record address on the disk. This is an automatic check and does not have to be programmed.

This is the same internal circuitry that is used by the COMPARE instruction. Care should be taken in programming that a normal-compare operation and the address-compare operation do not interfere with the setting of the equal, low, and high compare indicators set by a previous instruction.

Any Disk-Unit Error Condition—This indicator turns ON if any of the other disk storage indicators are ON. It can be tested by the program, and, if it is OFF, allows the program to proceed. If the indicator is ON, then the other indicators should be checked to determine where corrective measures should be taken.

Word Marks. Word marks are not affected.

Timing. T = .0115 (L_T + 1) ms.

Note. After each disk unit, read, or write operation, the program must test for error indications to prevent processing of unusable data.

Address Registers After Operation.

I-Add. Reg. A-Add. Reg. B-Add. Reg.
NSI BI dbb

Example. At the completion of a disk-read operation, test the any-disk-unit error condition indicator. If it is ON, branch to the routine labeled DISKER (0690) to determine the type of error condition. If it is OFF, continue in the main program, which tests the other disk unit indicators and branches to error routines if the respective indicator is ON. The routines are labeled: UNADCL (0790), WRLENR (0890), and RWPARC (0990), Figure 120.

SPS

LINE	COUNT	LABEL	OPERATION	(A) OPERAND				(B) OPERAND				d	
				ADDRESS	+	CHAR. ADJ.	±	ADDRESS	+	CHAR. ADJ.	±		
0.1.0			B	DISKER									Y
0.2.0			B	UNADCL									X
0.3.0			B	WRLENR									W
0.4.0			B	RWPARC									V

Autocoder

Label	Operation	OPERAND
B.I.N.	DISKER, Y	
B.I.N.	UNADCL, X	
B.I.N.	WRLENR, W	
B.I.N.	RWPARC, V	

Assembled Instruction: 480 B 690 Y
 690 B 790 X
 695 B 890 W
 700 B 990 V

Figure 120. Indicator Testing Routine

SPS

LINE	COUNT	LABEL	OPERATION	(A) OPERAND				(B) OPERAND				d
				ADDRESS	Z	CHAR ADJ.	Q	ADDRESS	Z	CHAR ADJ.	Q	
0.1.0		B	DISKER									Y
0.2.0		DISKER	B	UNADCL								X
0.3.0		B	WRLNR									W
0.4.0		B	RWPARC									V

Autocoder

Label	Operation	OPERAND
BIN	DISKER	Y
DISKER	BIN	UNADCL,X
BIN	WRLNR	W
BIN	RWPARC	V

Assembled Instruction: 480 B 690 Y
 690 B 790 X
 695 B 890 W
 700 B 990 V

Figure 120. Indicator Testing Routine

IBM 1407 Console Inquiry Station

The IBM 1407 Console Inquiry Station provides a direct and immediate means of communication between the station operator and IBM 1401 Data Processing System. Because the scope of applications processed by 1401 systems has increased, there is a need for some means of communication with the system. The IBM 1407 Console Inquiry Station (Figure 121) is designed to fill this need.

Located adjacent to the IBM 1401 Processing Unit console, the inquiry station can be used for reading data from storage or for inserting data or program steps, if necessary, into 1401 core storage.

When an inquiry is to be made, the operator presses the request enter key-light. As soon as the system is free to act on the request, the enter light comes on and the operator can type the message and enter it into 1401 core storage.

When the system completes the processing of the inquiry, it is transferred to the inquiry station by the stored program. The message is typed, and the operator may act on the reply.

The inquiry station printer has a 64-character double-case keyboard and a pin-feed platen. It can print ten digits (0-9), twenty-six alphabetic characters (A-Z), and twenty-eight special characters (Figure 122).

The table on which the console printer is located has an area on the left of the keyboard for program notebooks and other materials to aid the operator.

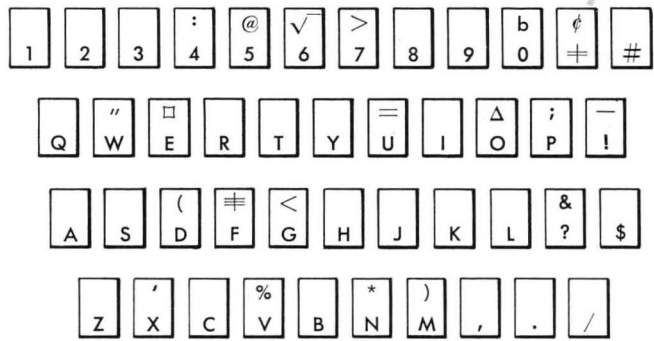

Figure 122. IBM 1407 Console Keyboard

The inquiry station is especially valuable when used with a RAMAC 1401 system. It can be used to call for data stored on a disk record. An account record or stock-status record needed by management can be requested by the operator and made available in a short time. Thus, management can, at a moment's notice, request information from the 1401 system and have an answer almost instantaneously.

For the user of the 1401 Model D system, the console inquiry station provides an input-output device. This system, consisting of the IBM 1401 Processing Unit, the IBM 1403 Printer, and IBM 729 Magnetic Tape Units, uses magnetic tape for entering stored programs. Now, the IBM 1407 Console Inquiry Station

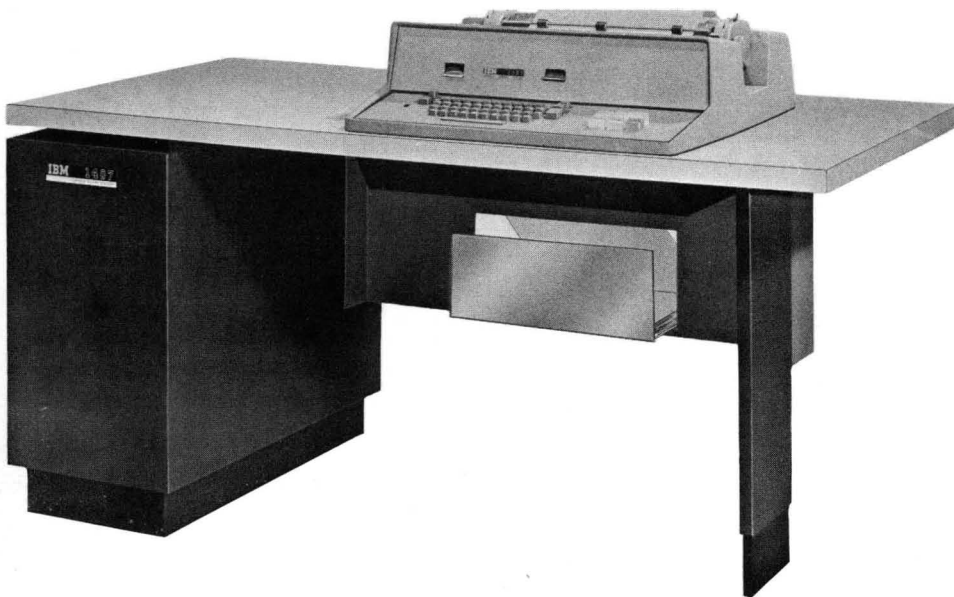

Figure 121. IBM 1407 Console Inquiry Station

permits manual alteration of the stored program without writing the changes on magnetic tape. Exception records can be typed on the console printer while the regular reports are printed on the 1403.

The IBM 1407 Console Inquiry Station provides the 1401 system user with an efficient and economical means of altering the stored program and examining data stored in the system.

The format of an inquiry or reply is controlled by the data necessary to perform the function. This means that the format is variable in all cases. The message is only as long as is necessary to provide the information. There are no format control keys or tapes. Format is under program control and is completely flexible. Pressing the clear or respond key ends a message to the 1401. When typing, a reply transmission is stopped by a group-mark with a word-mark (when the 1401 is in the RUN mode) or by pressing the clear key.

Thus, the programmer can provide different format for the data to be typed solely on the basis of the 1401 stored program.

IBM 1407 Console Inquiry Station Instructions

Read from Console Printer

Instruction Format.

Mnemonic	Op Code	A-address	B-address	d-character
MU	<u>M</u>	%T0	xxx	R

Function. This instruction causes the enter key-light to come ON, the keyboard to unlock, and the data (to be typed on the 1407) to enter 1401 core storage. The A-address specifies an inquiry station operation. The B-address is the high-order position in 1401 core storage wherein the data is to be stored. The d-character specifies a read-in operation. The inquiry request indicator must be ON to process this instruction.

Word Marks. A group-mark with a word-mark must be inserted in 1401 core storage to the right of the last character sent to the 1401 from the 1407. Another method of terminating a read-in operation is pressing the clear key (see *Clear Key*).

Timing. $T = .0115 (L_I + 1)$ ms + typing time.

Note. The lower case *b* (special character) or space bar causes a space to be taken and a blank to enter

core storage. If the b-key is pressed, a lower case *b* is printed. The method of entering data is discussed in the section on *Console Operation*.

Address Registers After Operation.

I-Add. Reg.	A-Add. Reg.	B-Add. Reg.
NSI	%30	B + L _B

Example. Transfer the data typed on the IBM 1407 to the area in 1401 core storage labeled INQIN (0785), Figure 123.

LINE	COUNT	LABEL	OPERATION	(A) OPERAND				(B) OPERAND				d			
				ADDRESS	±	CHAR. ADJ.	±	ADDRESS	±	CHAR. ADJ.	±				
0	1		MU	%T0											

Label	Operation	OPERAND			
MU	%T0				

Assembled Instruction: M %T0 785 R

Figure 123. Read into Storage

Write on Console Printer

Instruction Format.

Mnemonic	Op Code	A-address	B-address	d-character
MU	<u>M</u>	%T0	xxx	W

Function. This instruction causes data from 1401 storage to be typed by the inquiry station. While the data is being typed, the typeout light is ON. The B-address is the high-order position in 1401 core storage of the data to be transferred to the console printer. The d-character specifies a write operation.

Word Marks. A group-mark with a word-mark in 1401 core storage stops the transfer of data to the 1407 and causes a carriage return. Pressing the clear key also stops the transfer of data from the 1401 (see *Clear Key*).

Timing. $T = .0115 (L_I + 1)$ ms + typing time.

Note. Characters that have incorrect parity (even-bit) are typed as a ✖ if the process check stop switch is OFF. If the switch is ON, typing stops before typing the incorrect character.

Address Registers After Operation.

I-Add. Reg.	A-Add. Reg.	B-Add. Reg.
NSI	%30	B + L _B

Example. Type the data, beginning in the area labeled INQOUT (0785) and ending with a group-mark, with a word-mark (Figure 124).

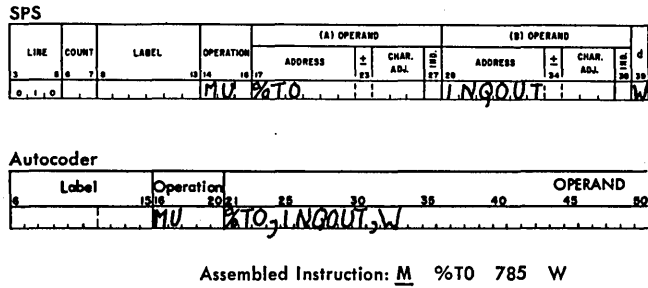

Figure 124. Read out of Storage

Read from Console Printer with Word Marks

Instruction Format.

Mnemonic	Op Code	A-address	B-address	d-character
LU	<u>L</u>	%T0	xxx	R

Function. This instruction causes the enter key light to come ON, the keyboard to unlock, and the data with word mark (to be typed on the 1407) to enter 1401 core storage. The A-address specifies an inquiry station operation. The B-address is the high-order position, in 1401 core storage, in which the data is to be stored. The d-character specifies a read-in operation. Word marks are entered by first pressing the word-mark key, and then pressing the associated character key. Characters with a word mark print in red. The inquiry request indicator must be ON to process this instruction.

Word Mark. A group-mark with a word-mark must be inserted in 1401 core storage to the right of the last character sent to the 1401 from the 1407. Another method of terminating a storage read-in operation is to press the clear key (see *Clear Key*).

Timing. $T = .0115 (L_I + 1)$ ms + typing time.

Note. The lower case *b* (special character) or space bar causes a space to be taken and a blank to enter core storage. If the b-key is pressed, a lower case *b* is printed. The method of entering data is discussed in the section on 1407 Console Operation.

Address Registers After Operation.

I-Add. Reg.	A-Add. Reg.	B-Add. Reg.
NSI	%30	B + L _B

Example. Transfer the data with word marks (typed on the 1407) to the area in 1401 core storage labeled INQIN (0785), Figure 125.

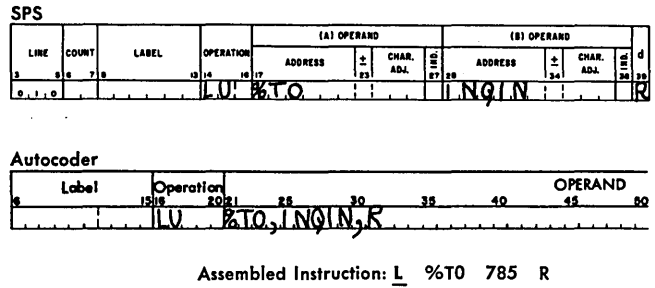

Figure 125. Read into Storage with Word Marks

Write on Console Printer with Word Marks

Instruction Format.

Mnemonic	Op Code	A-address	B-address	d-character
LU	<u>L</u>	%T0	xxx	W

Function. This instruction causes data from 1401 storage to be typed by the inquiry station. While the data is being typed, the typeout light is ON. The A-address specifies an inquiry station operation. The B-address is the high-order position in 1401 core storage of the data to be transferred to the typewriter. The d-character specifies a write operation.

Timing. $T = .0115 (L_I + 1)$ ms + typing time.

Word Marks. A group-mark with a word-mark stops the transfer of data to the 1407 and causes a carriage return. Pressing the clear key also stops the transfer of data from the 1401 (see *Clear Key*).

Note. Characters that have a word mark in association with them are typed in red. All other characters are typed in black. A space is printed as a lower case *b*. Characters with incorrect parity (even-bit) are typed as a \mathcal{K} if the process check stop switch is OFF. If the switch is ON, typing stops before typing the incorrect character.

Address Registers After Operation.

I-Add. Reg.	A-Add. Reg.	B-Add. Reg.
NSI	%30	B + L _B

Example. Type the data with word marks located in the area labeled INQOUT (0785) and ending with a group-mark with a word-mark (Figure 126).

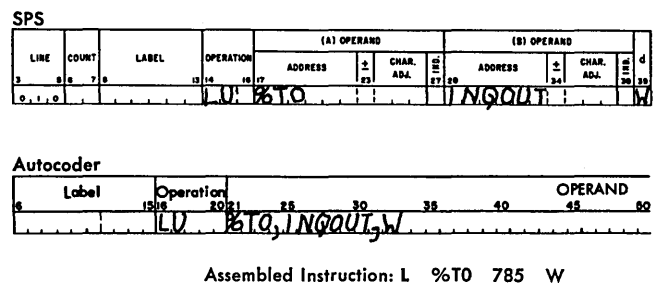

Figure 126. Write out of Storage with Word Marks

Line Space

Instruction Format.

Mnemonic	Op Code	A-address	B-address	d-character
LU or MU	<u>L</u> or <u>M</u>	%T0	xxx	W

Function. This instruction causes the console printer to space one line. The B-address is the storage location of a group-mark with a word-mark.

Timing. $T = .0115 (L_I + 1) \text{ ms} + \text{space time}.$

Word Marks. A group-mark with a word-mark must be at the B-address.

Note. Multiple line spacing is controlled by this instruction and by the setting of the line space lever.

Address Registers After Operation.

I-Add. Reg.	A-Add. Reg.	B-Add. Reg.
NSI	%30	B + 1

Example. Space a single line on the console printer. The storage position labeled GMWM (0895) contains a group-mark with a word-mark (Figure 127).

SPS

LINE	COUNT	LABEL	OPERATION	(A) OPERAND				(B) OPERAND				d	
				ADDRESS	±	CHAR. ADJ.	±	ADDRESS	±	CHAR. ADJ.	±		
3	8		LU	%T0									W
	0												

Autocoder

Label	Operation	OPERAND					
13-16	20-21	25	30	35	40	45	50
LU	%T0	GMWM	W				

Assembled Instruction: L %T0 895

Figure 127. Line Space

Branch if Indicator On

Instruction Format.

Mnemonic	Op Code	I-address	d-character
SPS B	<u>B</u>	xxx	x
A BIN			

Function. The d-character specifies the indicator tested. If the indicator is ON, the next instruction is taken from the I-address. If the indicator is OFF, the next

sequential instruction is taken. Figure 128 shows symbols that are valid d-character and the indicators they test.

d-CHARACTER	INDICATOR
*	Inquiry Clear
Q	Inquiry Request

Figure 128. IBM 1407 Branch Instruction d-Character

Indicators. Inquiry Clear – This indicator turns ON when the clear key-light is pressed, if the 1401 is in the RUN mode. It turns OFF when the 1401 program processes a console inquiry instruction or the start reset key on the 1401 console is pressed. It must be tested before processing the next inquiry.

Inquiry Request – This indicator turns ON when the request enter key-light is pressed to signal the 1401 that an inquiry is to be processed, and the 1401 is in the RUN mode. It is turned OFF after the 1401 processes a console inquiry instruction. Pressing the start reset key on the 1401 console or the clear key on the 1407 also turns this indicator off.

Word Marks. Word marks are not affected.

Timing. $T = .0115 (L_I + 1) \text{ ms}.$

Address Registers After Operation.

I-Add. Reg.	A-Add. Reg.	B-Add. Reg.
NSI	BI	dbb

Example. Branch to the inquiry routine labeled INQRUT (0950) if the inquiry request indicator is ON (Figure 129).

SPS

LINE	COUNT	LABEL	OPERATION	(A) OPERAND				(B) OPERAND				d	
				ADDRESS	±	CHAR. ADJ.	±	ADDRESS	±	CHAR. ADJ.	±		
3	8		B	INQRUT									Q
	0												

Autocoder

Label	Operation	OPERAND					
13-16	20-21	25	30	35	40	45	50
BIN	INQRUT	Q					

Assembled Instruction: B 950 Q

Figure 129. Test and Branch

Special Features

The special features described in this section are available for use in the IBM 1401 Data Processing System. They offer additional flexibility in applications where special processing requirements exist.

Multiply-Divide Feature

This feature makes it possible to perform direct multiplication and division in the IBM 1401 Data Processing System.

Multiply

Instruction Format.

Mnemonic	Op Code	A-address	B-address
M	@	xxx	xxx

Function. The multiplicand (data located in the A-field) is repetitively added to itself in the B-field. The B-field contains the multiplier in the high-order positions, and enough additional positions (low order) to allow for the development of the product. At the end of the multiply operation, the units position of the product is located at the B-address. The multiplier is destroyed in the B-field as the product is developed. Therefore, if the multiplier is needed for subsequent operations, it must be retained in another storage area.

Rules:

1. The product is developed in the B-field. The length of the B-field is determined by adding "1" to the sum of the number of digits in the multiplicand and multiplier fields.

Example:

1246	4-digit multiplicand
× 543	3-digit multiplier
<hr/>	
1	
+	
1	
<hr/>	
8	positions must be allowed in the B-field.

2. A word mark must be associated with the high-order positions of both the multiplier and multiplicand fields.

3. A- and B-bits need not be present in the units positions of the multiplier and multiplicand fields. The absence of zone bits in these positions indicates a positive sign. At the completion of the multiply operation the B-field will have zone bits in the units position of the product only. The multiply operation uses algebraic sign control (Figure 130).

Multiplier Sign	+	+	-	-
Multiplicand Sign	+	-	+	-
Sign of Product	+	-	-	+

Figure 130. Algebraic Sign Control for Multiplication

4. Zone bits that appear in the multiplicand field are undisturbed by the multiply operation. Zone bits in the units position of the multiplicand are interpreted for sign control.

Timing. The average time required for a multiply operation is:

$$T = .0115 (L_I + 3 + 2L_C + 5L_C L_M + 7L_M) \text{ ms.}$$

L_C = length of multiplicand field.

L_M = length of multiplier field.

A chart of approximate timings is included in the section on *Timing*.

Notes. The first addition within the multiply operation inserts zeros in the product field from the storage location specified by the B-address up to the units position of the multiplier.

The A-address register and the B-address register indicate positions within the A- and B-fields on which operations are currently being performed.

Word Marks. A word mark must be associated with the high-order positions of the multiplier and multiplicand fields.

Address Registers After Operation.

I-Add. Reg.	A-Add. Reg.	B-Add. Reg.
NSI	A minus the length of the multiplicand.	B minus the length of product field.

Example. Multiply:

Label	Location of Data Word	Contents of Data Word	Description
MULCAN	0502	1246	Multiplicand
MULIER	0065	543	Multiplier
PRODCT	0610		Product

The size of the product field is $4 + 3 + 1 = 8$. The multiplier is placed in the three high-order

positions of the PRODC T area (0603, 0604, and 0605). At the completion of the multiply operation, load the product in the area labeled OUT2 (0178). The units positions of the multiplier and multiplicand fields may be signed (Figure 131).

SPS

LINE	COUNT	LABEL	OPERATION	(A) OPERAND				(B) OPERAND				
				ADDRESS	±	CHAR. ADJ.	±	ADDRESS	±	CHAR. ADJ.	±	
0, 1, 0			Z A	MULLER				PRODC T	-		5	
0, 2, 0			M	MULCAN				PRODC T				
0, 3, 0			L C I A	PRODC T				OUT2				

Autocoder

Label	Operation	OPERAND
Z A	MULLER, PRODC T-5	
M	MULCAN, PRODC T	
L C I A	PRODC T, OUT2	

Assembled Instruction: ? 065 605
 @ 502 610
 L 610 178

Figure 131. Multiply

Divide

Instruction Format.

Mnemonic	Op Code	A-address	B-address
D	%	xxx	xxx

Function. This instruction divides the data (dividend) in the low-order positions of the B-field by the divisor located in the A-field, and develops the quotient in the high-order positions of the B-field. The remainder is left in the low-order positions of the B-field.

Rules:

1. The quotient is developed in the B-field. The length of the B-field is determined by adding "1" to the sum of the number of digits in the divisor and dividend fields.

Example:

543	1246	4 digit dividend
		3 digit divisor
	+ 1	8 positions must be allowed in the B-field.

2. A word mark must be associated with the high-order position of the A-field.

3. In all cases A- and B-bits (plus sign) or B-bit (minus sign) must appear in the units position of the dividend field. The divisor may be either signed or unsigned. If there are no bits in the units position of the divisor, the machine assumes the divisor factor is positive. The divide operation uses algebraic sign control (Figure 132).

Divisor Sign	+	+	-	-
Dividend Sign	+	-	+	-
Quotient Sign	+	-	-	+
Remainder Sign	+	-	+	-

Figure 132. Algebraic Sign Control for Division

4. The dividend is loaded in the low-order positions of the B-field (Figure 133) by a ZERO AND ADD instruction to insure that zeros are present in the high-order positions of the B-field.

Dividend ± 0000XXXX

Figure 133. Dividend in B-Field

5. The B-address in the DIVIDE instruction specifies the high-order position of the dividend.

At the completion of division:

- The quotient is in the high-order positions of the B-field. The location of the units position of the quotient, is the address of the units position of the dividend, minus the length of the divisor, minus one.
- The remainder is in low-order positions of the B-field.
- The sign of the quotient is over the units position of the quotient field.
- Because only one quotient digit can be developed at a time, it is important to address the high-order position of the dividend (B-address of the DIVIDE instruction). This insures that the first divide operation will result in a single high-order quotient digit. A dividend improperly addressed can cause an arithmetic overflow if the result of the first divide operation is greater than 9.

Note: A divide operation refers to the process of developing each quotient *digit*. If the quotient field is not large enough, no overflow is indicated. This is a programming error for which the machine does not check. Division by zero results in an arithmetic overflow condition. Figure 134 shows the result of a divide operation.

± ± XXXX XXX Quotient Remainder B-FIELD
--

Figure 134. Location of the Results of a Divide Operation

Extra zeros can be added to the dividend prior to a divide operation when a larger quotient is required. For each additional quotient digit desired,

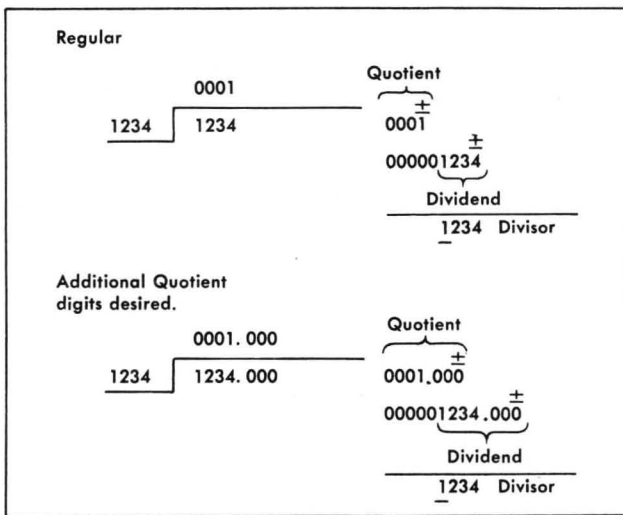

Figure 135. Additional Quotient Digits

place one zero to the right of the dividend as shown in Figure 135. Note that in this example, the units position of the quotient is *not* located in the position previously described in the section *At The Completion of Division, a.*

Word Marks. A word mark must define the high-order position of the divisor.

Timing. Average time required for the execution of a divide operation is calculated:

$$T = .0115 (L_I + 2 + 7 L_R L_Q + 8 L_Q) \text{ ms.}$$

L_Q = length of the quotient field.
 L_R = length of the divisor field.

A chart of approximate timings is included in the section on *Timing.*

Note. The quotient field is not cleared before actual division begins.

Address Registers After Operation.

I-Add. Reg.	A-Add. Reg.	B-Add. Reg.
NSI	A minus the length of the divisor	Tens position of quotient. If divisor has all zeros, the B-address register stands at the units position of the dividend minus the length of the divisor minus the length of the dividend minus 1.

Example. Figure 136 is a symbolic example for DIVIDE.

Label	Location of Data Word	Data Word	Description
DIVEND	0502	1246	Dividend
DIVSOR	0065	543	Divisor
QUOT	0985		Quotient

SPS

LINE	COUNT	LABEL	OPERATION	(A) OPERAND				(B) OPERAND				d		
				ADDRESS	±	CHAR. ADJ.	IS	ADDRESS	±	CHAR. ADJ.	IS			
0, 1, 0		ZA	DIVEND											
0, 2, 0		D	DIVSOR											

Autocoder

6	Label	Operation	15	20	25	30	35	40	OPERAND	45	50
	ZA	DIVEND, QUOT									
	D	DIVSOR, QUOT-3									

Assembled Instruction: ? 502 985
% 065 982

Figure 136. Division

Increased Core Storage

The IBM 1406 Storage Unit (Figure 137) is an additional component of the IBM 1401 Data Processing System. It is used with IBM 1401 processing units containing 4,000 positions of core storage. The 1406 increases the core storage capacity to as much as 16,000 positions. This additional storage capacity greatly increases the range of applications that can be economically handled by the IBM 1401.

IBM 1406 Storage Unit Models

The 1406, Model 1 contains a block of 4,000 core-storage positions. It increases the capacity of the system to 8,000 positions.



Figure 137. IBM 1406 Storage Unit

Model 2 contains a block of 8,000 core-storage positions. It increases the capacity of the system to 12,000 positions.

Model 3 contains a block of 12,000 core-storage positions. It increases the capacity of the system to 16,000 positions.

Addressing

The additional core-storage locations are addressed by the presence of zone bits located over the units position of each storage address over 3999. These zone bits are added to the basic 4,000-character coding system.

Storage Addresses	Zone Bits over Units Position of Address
4,000- 7,999	A
8,000-11,999	B
12,000-15,999	AB

Storage addresses 0000-3999 have zone bits over the hundreds position, and no zone bits over the units position of the 3-character address.

Storage addresses 4000-7999 have zone bits over the hundreds position, and A-bits (0 zone) over the units position of the 3-character address.

Storage addresses 8000-11,999 have zone bits over the hundreds position, and B-bits (11 zone) over the units position of the 3-character address.

Storage addresses 12,000-15,999 have zone bits over the hundreds position, and A- and B-bits (12 zone) over the units position of the 3-character address. Figure 138 is a chart of the addressing system.

The IBM 1401 addresses core-storage locations by assigning a digit value to each bit that appears over the hundreds and units positions of the 3-character address.

Bit and Location	Digit Value
A-bit over hundreds position	1
B-bit over hundreds position	2
A-bit over units position	4
B-bit over units position	8

The machine adds the assigned digit values of the hundreds and units positions to determine the thousand block of storage addressed. For example, to address core-storage locations, the IBM 1401 assigns digit values to the bits.

$$\begin{aligned}
 ?99 &= \frac{\text{A}}{\text{B}} = \frac{1}{2} = 3099 \\
 \text{I5R} &= \frac{\text{A}}{\text{B B}} = \frac{1}{2 8} = 11,959
 \end{aligned}$$

ADDRESS VALIDITY

The IBM 1401 checks each address to insure that it is valid for the storage capacity installed. The system stops on an address validity error, if an invalid address is encountered.

Core-Storage Capacity	Valid Addresses	Invalid Addresses
1,400	0000-1399	1400-15999
2,000	0000-1999	2000-15999
4,000	0000-3999	4000-15999
8,000	0000-7999	8000-15999
12,000	0000-11999	12000-15999
16,000	0000-15999	NONE

ACTUAL ADDRESSES	ZONE BITS OVER HUNDREDS POSITION	ZONE BITS OVER UNITS POSITION	3-CHARACTER ADDRESSES
0000 to 0999 1000 to 1999 2000 to 2999 3000 to 3999	No Zone Bits A-Bit (Zero-Zone) B-Bit (11-Zone) AB-Bits (12-Zone)	No Zone Bits No Zone Bits No Zone Bits No Zone Bits	000 to 999 ≠00 to Z99 100 to R99 ?00 to 199
4000 to 4999 5000 to 5999 6000 to 6999 7000 to 7999	No Zone Bits A-Bit (Zero-Zone) B-Bit (11-Zone) AB-Bits (12-Zone)	A-Bit (Zero-Zone) A-Bit (Zero-Zone) A-Bit (Zero-Zone) A-Bit (Zero-Zone)	00≠ to 99Z ≠0≠ to Z9Z 10≠ to R9Z ?0≠ to 19Z
8000 to 8999 9000 to 9999 10000 to 10999 11000 to 11999	No Zone Bits A-Bit (Zero-Zone) B-Bit (11-Zone) AB-Bits (12-Zone)	B-Bit (11-Zone) B-Bit (11-Zone) B-Bit (11-Zone) B-Bit (11-Zone)	001 to 99R ≠01 to Z9R 101 to R9R ?01 to 19R
12000 to 12999 13000 to 13999 14000 to 14999 15000 to 15999	No Zone Bits A-Bit (Zero-Zone) B-Bit (11-Zone) AB-Bits (12-Zone)	AB-Bits (12-Zone) AB-Bits (12-Zone) AB-Bits (12-Zone) AB-Bits (12-Zone)	00? to 991 ≠0? to Z91 10? to R91 ?0? to 191

Figure 138. Addressing System

ADDRESS ARITHMETIC

To facilitate address arithmetic, an additional operation code (MODIFY ADDRESS) is added to IBM 1401 systems equipped with more than 4,000 characters of core storage.

Modify Address

Instruction Format.

Mnemonic	Op Code	A-address	B-address
MA	#	xxx	xxx

Function. This instruction causes the 3-character field, specified by the A-address (A-field), to be added to the B-address (B-field). The result is stored in the B-field. The three numerical portions and the zones of the units and hundreds positions of the B-field make up the 3-character result. For example:

Location	Contents	3-Character Address	Actual Address
A-address	A-field	100	100
B-address	B-field	L2F	14326
	B-field result	M2F	14426

Word Marks. Word marks are not affected, and are not required to define the A- or B-fields. If word marks are present, they are ignored and remain unchanged in both fields.

Timing. T = .0115 (L_I + 9) ms.

Note: See rules for the addition of zone bits in the section on *Address Modification Without Indexing Feature.*

Address Registers After Operation.

I-Add. Reg.	A-Add. Reg.	B-Add. Reg.
NSI	A-3	B-1 or B-3

Example. Add the 3-character address labeled ADDA (0985) to the 3-character address labeled ADDB (1313), Figure 139.

SPS

LINE	COUNT	LABEL	OPERATION	(A) OPERAND				(B) OPERAND				d												
				ADDRESS	±	CHAR. ADA.	±	ADDRESS	±	CHAR. ADA.	±													
3	0			13	14	15	16	17	18	19	20	21	22	23	24	25	26	27	28	29	30	31	32	
0	1	0		MA			ADD.A					ADDB												

Autocoder

Label	Operation	OPERAND																						
MA		ADD.A	ADDB																					

Assembled Instruction: # 985 T13

Figure 139. Modify Address (Two-Address)

Modify Address

Instruction Format.

Mnemonic	Op Code	A-address
MA	#	xxx

Function. This format of the MODIFY ADDRESS instruction causes the 3-character field, specified by the A-address, to be added to itself. The result is stored in the A-field.

Word Marks. Word marks are not required to define the A-field. If they are present, they are ignored and remain undisturbed in the A-field.

Timing. T = .0115 (L_I + 9) ms.

Address Registers After Operation.

I-Add. Reg.	A-Add. Reg.	B-Add. Reg.
NSI	A-3	A-1 or A-3

Example. Double the address labeled ADDC (2956), and store the result at ADDC (Figure 140).

SPS

LINE	COUNT	LABEL	OPERATION	(A) OPERAND				(B) OPERAND				d											
				ADDRESS	±	CHAR. ADA.	±	ADDRESS	±	CHAR. ADA.	±												
3	0			13	14	15	16	17	18	19	20	21	22	23	24	25	26	27	28	29	30	31	32
0	1	0		MA			ADD.C																

Autocoder

Label	Operation	OPERAND																						
MA		ADD.C																						

Assembled Instruction: # R56

Figure 140. Modify Address (Single-Address)

Read Release and Punch Release Feature

With this feature it is possible to release the read-start-time and punch-start-time interlocks that normally occur during card-read and card-punch cycles, thus providing more processing time during input-output operations.

Start Read Feed

Instruction Format.

Mnemonic	Op Code
SRF	8

Function. This instruction works in conjunction with the read release special feature. It releases the interlock that occurs during read start time, and permits a gain of 21 milliseconds of processing time between

card-read cycles. Also, it activates the card-read feed and moves the next card into reading position.

Word Marks. Word marks are not affected.

Timing. $T = .0115 (L_I + 1)$ ms.

Notes. After the START READ FEED instruction is executed, a READ A CARD instruction must be given before the reader is ready to read the 9-row of the card. If the READ A CARD instruction comes too late, then the card is not read, and feeds into the NR pocket, and the machine stops. The reader light comes on, and the I-address register is at the location of the instruction following the one on which read release time was over-extended. To insure optimum processing time, a START FEED READ instruction should follow the READ A CARD instruction, within 10 ms, if continuous card reading is desired. Then the machine is ready to accept the next read instruction on the following cycle.

START READ FEED instructions can also be given in cases other than those that cause continuous card feeding, provided that a READ A CARD instruction follows within the next 21 milliseconds. For this reason subroutines that can be executed after the START READ FEED instruction has been given should be timed to determine if a READ A CARD instruction is necessary in the subroutine as well as in the main routine.

Address Registers After Operation.

I-Add. Reg. A-Add. Reg. B-Add. Reg.
 NSI Ap Bp

Example. Release the interlock on the card reader and feed a card (Figure 141).

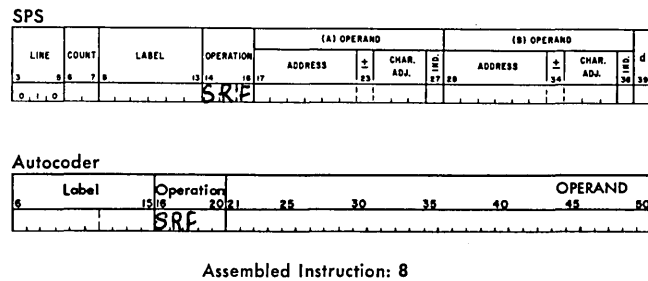

Figure 141. Read Release

Start Punch Feed

Instruction Format.

Mnemonic Op Code
 SPF 9

Function. This instruction works in conjunction with the punch release special feature. It releases the interlock that occurs during punch start time, and allows a gain of 37 milliseconds of processing time between card punch cycles. It also activates the card feed, and moves the card into punching position.

Word Marks. Word marks are not affected.

Timing. $T = .0115 (L_I + 1)$ ms.

Note. After a START PUNCH FEED instruction is executed, a PUNCH A CARD instruction must follow before the machine is ready to punch the 12-row of the card. If no PUNCH A CARD instruction is interpreted, the card feeds past the punch station without being punched and the machine stops. (The card punched on the previous cycle is not checked.) The I-address register is at the location of the instruction following the one on which punch release time was over-extended. For this reason, if cards are to be punched every cycle, a START PUNCH FEED instruction should be given within 22 ms after the PUNCH A CARD instruction, so that the machine is ready to punch the next card on the following punch cycle. If cards are not to be punched every cycle, a PUNCH A CARD instruction should always follow a START PUNCH FEED instruction within 37 ms to insure proper machine operation.

Address Registers After Operation.

I-Add. Reg. A-Add. Reg. B-Add. Reg.
 NSI Ap Bp

Example. Release the punch interlock, and feed a card (Figure 142).

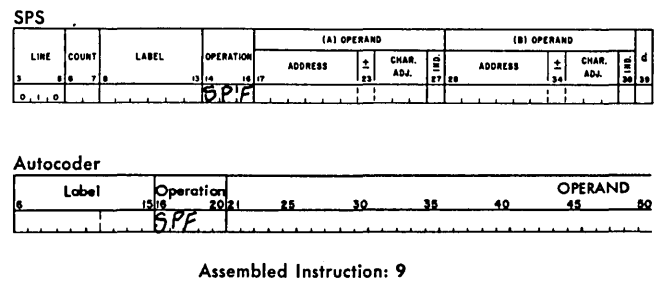

Figure 142. Punch Release

Punch Feed Read Feature

In some applications it is desirable to read information into the system, calculate, and punch the results in the same card from which the input data was read. By using the punch feed read feature, the card at the punch-feed-read station can be read while the card ahead of it is being punched. To permit this type of operation, a special set of 80 reading brushes, called *punch feed read*, is added to the IBM 1402 Card Read-Punch feed, one station ahead of the punch station (Figure 143). A special d-character specifies that the card is to be read from the punch side of the 1402. The normal read area (storage locations 001-080) receives the information from the punch feed read in the same manner as information is read from the read feed. A validity and a columnar hole-count check is made on each card column read from the punch-feed-read brushes. MLP card codes cannot be read by the punch feed read brushes.

The punching operation for machines equipped with punch feed read is the same as in the basic 1401. Storage positions 101-180 are specified as the punch area, and a hole-count check is made at the punch brushes. The hole-count check of pre-punched data is begun at the punch-read station and is completed at the punch-check station after punching has occurred.

Note: Punching in prepunched columns is acceptable, provided that the resultant character is valid and that the punches read at the punch-feed read station are not repeated. For example an X can be punched in a card column that already contains a 2, but punching a K (X and 2 punches) at the punch station if either an X or a 2 was already in the card, results in a hole-count check.

The d-character R activates the punch-feed-read brushes. It can be used with the operation codes PUNCH (4), WRITE AND PUNCH (6), and START PUNCH FEED (9).

If the combination instruction READ PUNCH (5), or WRITE READ PUNCH (7) is given, read and punch errors occur.

When punch release is combined with a punch feed read operation, processing time is reduced from 59 ms to 56 ms between successive punch cycles.

Read-Punch Feed

Instruction Format.

Mnemonic	Op Code	d-character
SPS P	<u>4</u>	R
A RF		

Function. When this instruction is used, the punch feed operates and reads the card entering the read station on the punch side. It also causes the card at the punch station to be punched. The R character modifier makes this instruction effective.

Word Marks. Word marks are not affected.

Timing. $T = .0115 (L_i + 1) \text{ ms} + \text{punch start time (37 ms)} + \text{punching time of 184 ms}$. Punch start time can be used for processing if the punch release special feature is installed.

Note. An additional 3 ms is required in excess of the normal punch time of 181 ms when the punch feed read feature is used. Processing time available is 19 ms without punch release and 56 ms if the punch release special feature is employed.

Address Registers After Operation.

I-Add. Reg.	A-Add. Reg.	B-Add. Reg.
NSI	dbb	181

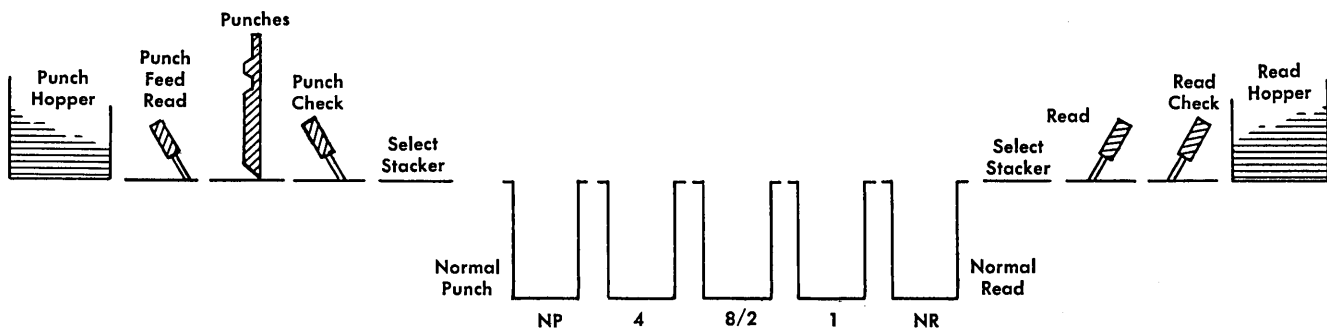

Figure 143. Punch Feed Read Schematic

Example. Read the card at the punch feed read station and punch a card (Figure 144).

SPS				(A) OPERAND				(B) OPERAND				d
LINE	COUNT	LABEL	OPERATION	ADDRESS	CHAR. ADJ.	IND.	ADDRESS	CHAR. ADJ.	IND.	IND.	d	
3	8	7	P								R	
0	1	0										

Autocoder									
Label	Operation	OPERAND							
5	15/16	20/21	25	30	35	40	45	50	
	RF								

Assembled Instruction: 4 R

Figure 144. Punch Feed Read

Read-Punch Feed and Branch

Instruction Format.

Mnemonic	Op Code	I-address	d-character
SPS P	<u>4</u>	xxx	R
A RF			

Function. This instruction causes the same function as READ-PUNCH FEED, except that an automatic branch to the I-address is effected.

Word Marks. Word marks are not affected.

Timing. $T = .0115 (L_I + 1) \text{ ms} + \text{punch start time } 37 \text{ ms}$ and punching time of 184 ms. Punch start time can be used for processing if the punch release special feature is installed.

Address Registers After Operation.

I-Add. Reg.	A-Add. Reg.	B-Add. Reg.
NSI	BI	181

Example. Read the card at the punch-feed-read station, punch a card, and branch to START6 (0598) for the next instruction (Figure 145).

SPS				(A) OPERAND				(B) OPERAND				d
LINE	COUNT	LABEL	OPERATION	ADDRESS	CHAR. ADJ.	IND.	ADDRESS	CHAR. ADJ.	IND.	IND.	d	
3	8	7	P	START6							R	
0	1	0										

Autocoder									
Label	Operation	OPERAND							
5	15/16	20/21	25	30	35	40	45	50	
	RF	START6							

Assembled Instruction: 4 598 R

Figure 145. Punch Feed Read and Branch

Write-Read Punch Feed

Instruction Format.

Mnemonic	Op Code	d-character
SPS WP	<u>6</u>	R
A WRF		

Function. This instruction causes the printer to operate and print a line, and the punch unit to read a card, and also causes the card at the punch station to be punched. The d-character R specifies that the card at the punch feed station is to be read. The printer takes priority and operates first, but the signal to start the punch feed read is automatically given before the end of the print operation, so that actual card reading starts soon after the print cycle is complete.

Word Marks. Word marks are not affected.

Timing. $T = .0115 (L_I + 1) \text{ ms} + \text{the timing conditions for print and punch overlap (see Timing)}$. The print operation normally takes 84 ms. Punch start time is 37 ms and the punch reading time is 184 ms. An additional 3 ms are added to the normal punching time of 181 ms. Normal processing time available is 19 ms.

Note. If the print storage special feature is installed in the system, the automatic signal to start the punch feed read operation is given shortly after the transfer to data to the print storage area. Thus, additional processing time can be gained by using print storage.

Address Registers After Operation.

I-Add. Reg.	A-Add. Reg.	B-Add. Reg.
NSI	dbb	181

Example. Print a line, read a card, and punch a card from the punch side of the 1402 (Figure 146).

SPS				(A) OPERAND				(B) OPERAND				d
LINE	COUNT	LABEL	OPERATION	ADDRESS	CHAR. ADJ.	IND.	ADDRESS	CHAR. ADJ.	IND.	IND.	d	
3	8	7	W/P								R	
0	1	0										

Autocoder									
Label	Operation	OPERAND							
5	15/16	20/21	25	30	35	40	45	50	
	WRF								

Assembled Instruction: 6 R

Figure 146. Print and Punch Feed Read

Write-Read Punch Feed, and Branch

Instruction Format.

Mnemonic	Op Code	I-address	d-character
SPS WP	<u>6</u>	xxx	R
A WRF			

Function. Same as WRITE-READ PUNCH FEED except

that the program branches to the I-address for the next instruction.

Word Marks. Word marks are not affected.

Timing. $T = .0115 (L_I + 1) \text{ ms} +$ the timing conditions for print and punch overlap (see *Timing*). The print operation normally takes 84 ms. Punch start time is 37 ms and the punch reading time is 184 ms. An additional 3 ms are added to the normal punching time of 181 ms. Normal processing time available is 19 ms.

Note. If the print storage special feature is installed in the system, the automatic signal to start the punch feed read operation is given shortly after the transfer of data to the print storage area. Thus, additional processing time can be gained by using print storage.

Address Registers After Operation.

I-Add. Reg. A-Add. Reg. B-Add. Reg.
 NSI BI 181

Example. Print a line, read and punch a card from the punch side of the IBM 1402, and branch to START6 (0895) for the next instruction (Figure 147).

SPS

LINE	COUNT	LABEL	OPERATION	(A) OPERAND				(B) OPERAND				d	
				ADDRESS	±	CHAR. ADJ.	±	ADDRESS	±	CHAR. ADJ.	±		
3	8	7	WRF	START6									R

Autocoder

Label	Operation	OPERAND						
6	15	20	25	30	35	40	45	50
WRF	START6							

Assembled Instruction: 6 895 R

Figure 147. Print, Punch Feed Read, and Branch

Print Storage Feature

This special feature provides 100 or 132 non-addressable extra positions of core storage. They are used as temporary storage for printer output data.

When this feature is installed, the WRITE instruction transfers the data in the printer area (storage location 201-332) to print storage. Two milliseconds after the WRITE instruction is given, the normal printer interlock is released and processing can continue. Thus, available processing time during a 100 ms cycle is 98 ms, as opposed to the 16 ms processing time available when the machine is not equipped with print storage. The print storage area interlocks for 84 ms during

printing. Therefore, another WRITE instruction given during this 84 ms will cause the program to stop until the interlock is released.

With this feature, two indicators can be tested by the BRANCH IF INDICATOR ON (Bxxxxd) instruction.

The print storage busy indicator turns ON during the first 83 1/3 ms of the print cycle. The d-character P tests the indicator. If it is ON, the program branches; if it is OFF, the next sequential program step is taken.

The printer error indicator (d-character of ≠) should not be tested until the program has determined that the print-storage busy indicator is OFF. If the error indicator is tested before the busy indicator turns OFF, the system interlocks until the print-storage operation in process is completed.

The carriage busy indicator turns ON during forms movement time. The d-character R tests this indicator. If it is ON, the program branches; if it is OFF, the next sequential program step is taken.

Additional Print Control Feature

The number of available print positions in the basic IBM 1403 Printer increases from 100 to 132 with this feature. The core-storage area reserved for printing when additional print control is installed includes locations 201-332.

Expanded Print Edit Feature

The basic operations of the MOVE CHARACTERS AND EDIT instruction can be increased by the expanded print edit feature. With this feature, asterisk protection, floating dollar sign, decimal control, and sign control left, operations can be performed. The zero-suppression code in the control word should be in the position immediately to the left of the decimal, except as required in *Decimal Control*.

Note: Floating dollar sign and asterisk protection or floating dollar sign and decimal control cannot be used in the same edit operation. When asterisk protection and decimal control are combined, and a blank data field is edited, the result is asterisks in all positions to the left of, but not including, the decimal-control position.

Asterisk Protection

When asterisks are to appear to the left of significant digits, the asterisk protection feature is used (Figure 148). The control word is written with the asterisk

A-field	00257426
Control word (B-field)	bbb, b*0. bb&CR
Forward scan	002,574.26 CR
Reverse scan	**2,574.26 CR
Results of edit	**2,574.26 CR

Figure 148. Asterisk Protection

immediately to the left of the zero suppression code. Zero-balances can be protected with asterisks by placing control zeros in the right-most position. In this instance, asterisks print in all positions including the decimal position.

Forward Scan:

1. The normal editing process proceeds until the asterisk is sensed.
2. The corresponding digit from the A-field replaces the asterisk (in the output field).
3. The editing process continues normally until the B-field word mark is sensed and removed.

Reverse Scan:

1. Asterisks replace zeros, blanks, and commas, to the left of the first significant digit.
2. The word mark (set during the forward scan) signals the end of editing. It is erased, and the operation is stopped.

Floating Dollar Sign

This feature causes the insertion of a dollar sign in the position at the left of the first significant digit in an amount field (Figure 149). The control word is written with the \$ immediately to the left of the zero-suppression code.

Note. The control word must be larger than the A-field. Three scans are necessary to complete this editing operation.

A-field	00257426
Control word (B-field)	bbbb, b\$0. bb
First forward scan	002,574.26
Reverse scan	bbb 2,574.26
Second forward scan	\$2,574.26
Results of edit	\$2,574.26

Figure 149. Floating Dollar Sign

First Forward Scan:

1. The editing proceeds until the \$ is sensed.
2. The corresponding digit from the A-field replaces the \$ (in the output field).
3. Editing continues until the B-field word mark is sensed and removed.

Reverse Scan:

1. Blanks replace both zeros and commas to the left of the first significant digit.
2. The reverse scan continues until the word mark (set during the first forward scan) signals the start of the second forward scan.

Second Forward Scan:

1. The word mark is erased and the scan continues until the first blank position is sensed. This blank position is replaced by \$, and the operation stops.

Sign Control Left

CR or minus symbols can be placed at the left of a negative field, if the sign control left feature is used (Figure 150). The control word is written with the CR or minus symbols in the high-order position.

A-field	00378940
Control word (B-field)	CR&bbb, bb0. bb
Forward scan	CRb003, 789.40
Reverse scan	CRbbb3, 789.40
Results of edit	CR 3,789.40

Figure 150. Sign Control Left

Forward Scan:

1. The scan proceeds until the zero suppression character in the control field is sensed.
2. The corresponding character from the A-field is placed in this position of the output field.
3. A word mark is automatically inserted in this position in the output field.
4. Editing continues and the CR or minus symbols are undisturbed in their corresponding positions in the output field, only if the sign of the A-field is minus. If the sign is plus, they are blanked.

Reverse Scan:

1. Blanks in the output field replace zeros and commas. The scan continues until the automatically-set word mark is sensed.
2. This word mark is erased and the operation ends.

Decimal Control

This feature insures that decimal points print only when there are significant digits in the A-field (Figure 151).

Two scans are sufficient to complete this editing operation, *unless* the field contains no significant digits. Then three scans are required.

First Forward Scan:

1. When the zero suppression code (0) is sensed during editing, the corresponding digit from the A-field replaces this position.
2. A word mark is set automatically in this position in the B- (output) field.
3. Editing continues normally until the B-field word mark is sensed and removed.

Reverse Scan:

1. Blanks in the output field replace zeros and commas until the decimal point is sensed.
2. The decimal point and the digits at its right are unaltered. The automatically-set word mark is erased. If there are no significant digits in the field, the second forward scan is initiated. Otherwise, the edit operation stops.

Second Forward Scan:

1. Blanks replace the zeros at the right of the decimal point and the decimal point itself.
2. The operation stops at the decimal column.

1. A-field	00000
Control word (B-field)	bbb. b0
First forward scan	000.00
Reverse scan	bbb. 00
Second forward scan	bbb
Results of edit	(Blank Field)
2. A-field	29437
Control word (B-field)	bbb. b0
First forward scan	294.37
Reverse scan	294.37
Result of edit	294.37
3. A-field	00001
Control word (B-field)	bbb. b0
First forward scan	000.01
Reverse scan	bbb. 01
Results of edit	.01

Figure 151. Decimal Control

Indexing Feature

Many IBM 1401 programs require that the same operations be performed repetitively, with a change only in the A- or B-address. Modifying these addresses, each time a repetitive operation is performed, requires several program steps, and additional storage locations which must be set aside for this purpose.

When the indexing feature is installed, three *index locations* are provided in the IBM 1401 Processing Unit to modify addresses automatically. This means that fewer instructions are needed and storage space is conserved, thus providing for faster program execution and over-all simplification of programming effort.

INDEX LOCATION ADDRESSES

Addresses assigned to the index locations are:

Index Location	Storage	Address
1	087-089	089
2	092-094	094
3	097-099	099

TAGGING

It is necessary to tag each address by an indicator so that the 1401 knows which index location is to be used to modify the instruction address.

A combination of A- and B-bits in the *tens* position of the A- or B-address of an instruction (AAA) (BBB), selects the index location.

Index Location	Tens Positions	Zone Punch
1	A-bit, No B-bit	Zero
2	B-bit, No A-bit	Eleven
3	A-bit, B-bit	Twelve

ADDRESS MODIFICATION

The primary use of index locations is to modify addresses automatically by adding (absolute) the contents of an index location to an address. Both the A-address and the B-address can be modified by the contents of any index location. Only core storage addresses can be modified.

The modification of the A- and B-addresses occurs in their respective address registers. For instance, if the A-address is indexed, the indexing occurs in the A-address register. This means the original instruction in storage is in no way changed or modified.

The index locations can be used as normal storage positions when not being used as index locations.

The index factor can be placed in the index location by normal programming, such as an add or move operation. The index factor can be changed by normal arithmetic ADD and SUBTRACT instructions, following the word mark rules for those instructions. In such cases a word mark should be set by an initialization routine in the high-order position of the index location.

Note. See *Address Modification* section for uses and examples of the indexing feature.

Store Address Register Feature

This special feature makes it possible to store the contents of the A- and B-address registers. Thus, the A- and B-addresses of program instructions can be modified directly in cases where variable length records are being processed. This facility also makes it easier to re-enter the main program from a subroutine. Because the address of the next instruction in sequence can be retained, program re-entry is simplified.

A subroutine is a set of program instructions that are executed, if a particular condition arises during the main routine. For example, if an unequal compare occurs during processing, the program branches to a subroutine in which a special set of instructions handles the condition.

Each time a subroutine is used, some method must be employed to link it with the main program. The function of the STORE A-ADDRESS REGISTER, and STORE B-ADDRESS REGISTER instructions is to establish subroutine linkage so that upon leaving the sequence of the main program it is possible to execute the steps of the subroutine, and return to the main program where the sequence was interrupted.

Store A-Address Register

Instruction Format.

Mnemonic	Op Code	A-address
SAR	Q	xxx

Function. This instruction stores the contents of the A-address register from the previous operation, in the three-position field that has its units position defined by the A-address of the STORE A-ADDRESS REGISTER instruction.

Word Marks. Word marks are not affected.

Timing. $T = .0115 (L_I + 5)$ ms.

Address Registers After Operation.

I-Add. Reg.	A-Add. Reg.	B-Add. Reg.
NSI	A-3	Ap

Example. Store the contents of the A-address register in area labeled AADRG (0625), Figure 152.

SPS

LINE	COUNT	LABEL	OPERATION	(A) OPERAND				(B) OPERAND				d	
				ADDRESS	±	CHAR. ADA.	IND.	ADDRESS	±	CHAR. ADA.	IND.		
0.1.0		SAR	AADRG										

Autocoder

Label	Operation	OPERAND
SAR	AADRG	

Assembled Instruction: Q 625

Figure 152. Store Contents of A-Address Register

Store B-Address Register

Instruction Format.

Mnemonic	Op Code	A-address
SBR	H	xxx

Function. This instruction stores the contents of the B-address register resulting from the previous operation, in the three-position field that has its units position defined by the A-address of the STORE B-ADDRESS REGISTER instruction.

Word Marks. Word marks are not affected.

Timing. $T = .0115 (L_I + 4)$ ms.

Note. If indexing is installed in the IBM 1401, the functioning of all branch commands is altered to simplify subroutine linkage. With these alterations, each time a branch occurs as a result of one of these commands, the address of the next sequential instruction in the main routine is inserted in the B-address register. See Note under Logic Operations.

Although the subroutine may be entered from many distinct points in the main program, this use of the SBR operation makes the subroutine linkage complete.

Address Registers After Operation.

I-Add. Reg.	A-Add. Reg.	B-Add. Reg.
NSI	A-3	Bp

Example. The main routine branches to a multiply subroutine labeled MULTRU (0495). This example shows the last step in the main routine and the first and last steps of the multiply routine, and illustrates subroutine linkage (Figure 153). The last instruction (labeled LAST) plus three will contain the address of the next instruction in the main routine.

SPS

LINE	COUNT	LABEL	OPERATION	(A) OPERAND				(B) OPERAND				d	
				ADDRESS	±	CHAR. ADA.	IND.	ADDRESS	±	CHAR. ADA.	IND.		
0.1.0		B	MULTRU										
0.2.0		SBR	LAST + 3										
0.3.0		B	0000										

Autocoder

Label	Operation	OPERAND
BU	MULTRU	
SBR	LAST+3	
LAST	B	0

Figure 153. Store Contents of B-Address Register

Move Record Feature

This feature provides a special MOVE instruction that makes it possible to move a complete record from one storage area to another, without regard to word marks within the record. This instruction is especially desirable in magnetic tape operations.

Move Characters to Record or Group Mark

Instruction Format.

Mnemonic	Op Code	A-address	B-address
SPS MCM	<u>P</u>	xxx	xxx
A MRCM			

Function. This operation code makes it possible to move an entire record from one core-storage area to another, regardless of the presence of word marks in either field. The A- and B-addresses specify the high-order position of the respective areas. Transmission starts from the high-order addresses, and continues until a record mark (A82 bits) or a group-mark with a word-mark (WMB A8421 bits) is sensed in the A-field. The record mark or group mark transfers to the B-field.

Word Marks. Word marks within the area do not affect the MOVE CHARACTERS TO RECORD OR GROUP MARK operation. Any word marks in the B-field remain unchanged. A-field word marks are not transmitted to the B-field.

Timing. $T = .0115 (L_I + 1 + 2 L_A)$ ms.

Address Registers After Operation.

I-Add. Reg.	A-Add. Reg.	B-Add. Reg.
NSI	A + L _A	B + L _A

(The length of the A-field includes the group-mark with word-mark or record mark)

Example. Move the tape record that has its high-order character in the location labeled TARCIN (0679) to another area of core storage beginning at the label WTAREC (0985), Figure 154.

LINE	COUNT	LABEL	OPERATION	(A) OPERAND	(B) OPERAND	d
3	0	0		ADDRESS 13 14 15 16 17 18 19 20 21 22 23 24 25 26 27 28 29 30 31 32 33 34 35 36 37 38 39	ADDRESS 13 14 15 16 17 18 19 20 21 22 23 24 25 26 27 28 29 30 31 32 33 34 35 36 37 38 39	
0	1	0				
0	2	0				
				MCM TARCIN	WTAREC	

Label	Operation	OPERAND
6	15 16 17 18 19 20 21 22 23 24 25 26 27 28 29 30 31 32 33 34 35 36 37 38 39	40 41 42 43 44 45 46 47 48 49 50
		MRCM TARCIN, WTAREC

Assembled Instruction: P 679 985

Figure 154. Move Record

High-Low-Equal Compare Feature

This feature expands the compare operation to include indicators for high, low, or equal conditions. Additional d-characters are included so that the BRANCH IF INDICATOR ON instruction can test for these conditions. The basic machine permits testing for unequal conditions only.

Test High, Low, or Equal Compare

Instruction Format.

Mnemonic	Op Code	I-address	d-character
SPS B	<u>B</u>	xxx	x
A			see chart

Function. This instruction tests the compare indicator for the result of the previous compare operation and branches to the I-address, if the condition specified by the d-character is present:

Autocoder	d-character	Branch to I-address if:
BE	S	B = A (B equals A)
BL	T	B < A (B is less than A)
BH	U	B > A (B is greater than A)

If the condition is not present, the program continues with the next sequential instruction.

Word Marks. Word marks are not affected.

Timing. $T = .0115 (L_I + 1)$ ms.

Address Registers After Operation.

I-Add. Reg.	A-Add. Reg.	B-Add. Reg.
NSI	BI	dbb

Example. Compare the data at RECNO (0596) to the control number at CONTNO (0495). If the data at RECNO is higher than the control number at CONTNO, branch to GRTAN (0797) for the next instruction (Figure 155).

LINE	COUNT	LABEL	OPERATION	(A) OPERAND	(B) OPERAND	d
3	0	0		ADDRESS 13 14 15 16 17 18 19 20 21 22 23 24 25 26 27 28 29 30 31 32 33 34 35 36 37 38 39	ADDRESS 13 14 15 16 17 18 19 20 21 22 23 24 25 26 27 28 29 30 31 32 33 34 35 36 37 38 39	
0	1	0				
0	2	0				
				C CONTNO	RECNO	
				B GRTAN		U

Label	Operation	OPERAND
6	15 16 17 18 19 20 21 22 23 24 25 26 27 28 29 30 31 32 33 34 35 36 37 38 39	40 41 42 43 44 45 46 47 48 49 50
		C CONTNO, RECNO
		BH GRTAN

Assembled Instruction: C 495 596
B 797 U

Figure 155. Compare

Sense Switches Feature

Six sense switches make it possible to control the stored program from the console (Figure 156). The **BRANCH IF INDICATOR ON** instruction expands to allow the program to test each switch.

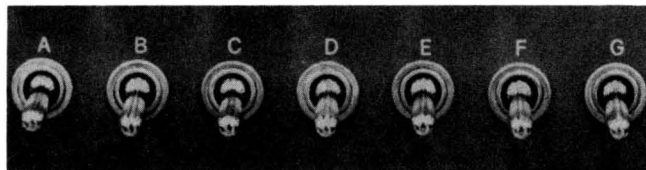

Figure 156. Sense Switches

For example, a sense switch is turned ON if printing only is required for a given job. If the switch is OFF, the data is to be printed and punched.

The program can be written to interrogate the setting of this sense switch, to determine if the data is to be printed and punched or just printed. The setting of a sense switch should not be changed while the system is operating.

Branch if Indicator On

Instruction Format.

Mnemonic	Op Code	I-address	d-character
SPS B	<u>B</u>	xxx	x
A BIN + d-character			

Function. This instruction tests the position of the toggle switch specified by the d-character. If the switch is in the ON position, the next instruction is taken from the I-address. If it is OFF, the program continues with the next sequential instruction.

d-character	Branch to the I-address if:
B	Sense switch B is on
C	Sense switch C is on
D	Sense switch D is on
E	Sense switch E is on
F	Sense switch F is on
G	Sense switch G is on

Word Marks. Word marks are not affected.

Timing. $T = .0115 (L_r + 1)$ ms.

Notes. Sense switch A (last card switch) is standard in all systems equipped with an IBM 1402 Card Read-Punch. When the last card passes the second reading brushes, and switch A is in the ON position, the last-card indicator is turned ON and a B xxx A instruction causes a branch to the I-address. It is turned OFF: on a run-in; if the switch is physically turned OFF; or if the start reset key is pressed.

Address Registers After Operation.

I-Add. Reg.	A-Add. Reg.	B-Add. Reg.
NSI	BI	dbb

Example. Branch to the subroutine labeled CLWARE (beginning at 0585) if sense switch G is ON (Figure 157).

SPS		(A) OPERAND				(B) OPERAND					
LINE	COUNT	LABEL	OPERATION	ADDRESS	±	CHAR. ADJ.	±	ADDRESS	±	CHAR. ADJ.	d
2	9	B	CLWARE								G
0	1	0									

Autocoder											
8	Label	15	16	20	21	25	30	35	40	45	50
	BIN										

Assembled Instruction: B 585 G

Figure 157. Test and Branch if Indicator On

Compressed Tape Operations Feature

This feature makes it possible for the IBM 1401 Data Processing System to read compressed tape prepared by the IBM 7070 Data Processing System, and to expand it within 1401 core storage for processing by the stored program.

The 7070 writes a compressed tape record under control of the WRITE WITH ZERO ELIMINATION (TWZ or TWC) instruction. By using this 7070 instruction, as many as five high-order zeros in each numerical word in storage can be eliminated while the data is recorded on magnetic tape, thus conserving tape capacity and read-write time.

The READ COMPRESSED TAPE and MOVE AND INSERT ZEROS operation codes are incorporated in the 1401 to enable it to process compressed tape records.

Read Compressed Tape

Instruction Format.

Mnemonic	Op Code	A-address	B-address	d-character
MU	<u>M</u>	%Cx	xxx	R

Function. This operation code causes an entire tape record to be read into core storage beginning at the B-address and ending with the detection of an inter-record gap (IRG) in the tape record. A group-mark without a word-mark is placed in storage at the right of the last data character transmitted when the IRG is sensed. At the end of the operation, the B-address register contains the address of the inserted group mark.

Mode changes (alpha to numerical and vice versa) are made automatically, and are controlled by the

presence of mode change characters (Δ) in the tape record.

Word Marks. Word marks are not affected.

Timing. $T = .0115 (L_I + 1) \text{ ms} + T_M$.

Address Registers After Operation.

I-Add. Reg. NSI	A-Add. Reg. %3x	B-Add. Reg. Address of the inserted group mark
--------------------	--------------------	--

Example. Read a tape record from tape unit 2 (labeled 2) in the area of core storage labeled TPAREA (0498), Figure 158.

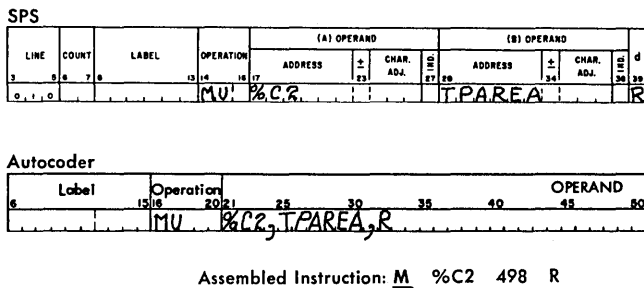

Figure 158. Read Compressed Tape

Move and Insert Zeros

Instruction Format.

Mnemonic MIZ	Op Code <u>X</u>	A-address xxx	B-address xxx
-----------------	---------------------	------------------	------------------

Function. The MOVE AND INSERT ZEROS instruction moves the compressed tape data that was read into core storage by a READ COMPRESSED TAPE instruction to another storage area, and expands each field to fill the storage locations allotted to it by the field-defining word marks. The A-address specifies the units position of the compressed tape record in core storage. (To obtain the A-address, execute a STORE B-ADDRESS REGISTER instruction immediately following the execution of the READ COMPRESSED TAPE instruction. This stores the address that contains the group mark (\neq) that indicated the end of the compressed tape record.) The B-address of the MOVE AND INSERT ZEROS instruction specifies the units position of the expanded area. The data moves from the compressed area to the expanded area, and zeros are inserted into the high-order positions of the expanded-area fields.

Word Marks. Word marks must be preset in the expanded area to indicate the high-order position of each field. A group-mark, with a word-mark that

has also been preset by the program, must appear at the position immediately to the left of the high-order storage location of the A-field. It is this group mark that signals the end of the MOVE AND INSERT ZEROS operation.

Timing. $T = .0115 (L_I + 1 + 2 \Sigma L_A + \Sigma L_N) \text{ ms}$.

Note. When the IBM 7070 writes a tape record, it writes each word on tape in either the alphabetic or numerical mode. Each time the mode changes from alphabetic to numerical or vice versa, a mode change character, delta (Δ), is automatically written on tape. Each time a delta is read into IBM 1401 core storage by the READ COMPRESSED TAPE instruction, it changes the setting of an internal switch to either the alphabetic or the numerical indication, corresponding to the mode. Thus, at the completion of the operation, the mode change switch indicates the mode setting of the last tape character read.

In the expand operation, the setting of the internal mode switch determines the method of operation. The machine works on the MOVE AND INSERT ZEROS operation from right to left, moving the data, field by field, from the compressed area to the expanded area. If the compressed area field is alphabetic, it is moved, intact, to the expanded area field, as defined by the preset word marks. To insure proper operation, the expanded alphabetic fields should be equal in length to the alphabetic fields read from tape. If the data are numerical, they are moved digit-by-digit, low order to high order, until a zone bit (indicating sign position) or Δ (delta) is encountered. If any high-order positions in the expanded field are unfilled, zeros are inserted until a word mark is sensed. During this operation, the detection of a Δ in the compressed area changes the setting of the mode switch, and the mode of operation changes from alphabetic to numerical, or vice-versa.

Address Registers After Operation.

I-Add. Reg. NSI	A-Add. Reg. Address of preset group-mark with a word-mark -1 at im- mediate left of tape read-in area.	B-Add. Reg. At last word-mark in B-field minus one.
--------------------	---	---

Example. A 4-word compressed tape record is prepared by the IBM 7070:

<i>Field</i>	<i>Mode</i>	<i>IBM 7070 Storage Words</i>
Part name	alpha	two words
Part number	numerical	one word, always plus
Unit cost	numerical	one word, always plus

The part number can be from two to seven digits in length. The unit cost can be from three to six

digits. The compressed tape record, written by the 7070 for a specific part, looks like this:

EXTbbSHANKΔ0475C1154E

The letter C is a plus sign over units digit 3. The E is a plus sign over units digit 5. The mode switch is set to alpha mode during the compressed tape operation instruction time. Therefore, it was changed to the numerical mode by the Δ. It is necessary to perform the expand operation before the next READ COMPRESSED TAPE instruction.

SPS

LINE	COUNT	LABEL	OPERATION	(A) OPERAND				(B) OPERAND				d
				ADDRESS	CHAR. ADJ.	CHAR. ADJ.	ADDRESS	CHAR. ADJ.	CHAR. ADJ.	ADDRESS		
0, 1, 0			MU %C2					0700				R
0, 2, 0			SBR EXPAND+3				3					
0, 3, 0		EXPAND	MIZ	0,000				0724				

Autocoder

Label	Operation	OPERAND
MU	%C2, 700, R	
SBR	EXPAND+3	
EXPAND	MIZ	0, 724

Assembled Instruction:

- M %C2 700 R located in storage positions 433-440
- H 448 located in storage positions 441-444
- X 000 724 located in storage positions 445-451

Figure 159. Read and Expand Tape Record

Figure 159 shows the three program steps that read and expand the compressed tape record for this example. A group-mark with a word-mark has been preset in position 0699.

The READ COMPRESSED TAPE instruction reads into IBM 1401 storage locations 0700-0721:

EXTbbSHANKΔ0475C1154E‡

After the operation, the B-address register contains the address of the group mark (0721). The STORE B-ADDRESS REGISTER instruction modifies the MOVE AND INSERT ZEROS instruction so that the A-address contains 721:

X	000	724	before
X	721	724	after

The maximum size of the compressed tape record is 24 positions (to accommodate a 10-character part name, a 7-digit part number, a 6-digit unit cost, and the mode-change character). Thus, the expanded area is defined as locations 700-724 (the 25th position is for the group mark, ‡). Word marks are preset in positions 700, 711, and 718.

The MOVE AND INSERT ZEROS instruction first tests the mode switch, and then moves the unit cost field and the group mark (1154E ‡) from the compressed

field locations, 716-721, to the expanded field locations, 719-724. The detection of the zone bits in the letter C of the part number indicates the units position of the next field. Because no mode change character is detected, the mode switch continues to indicate numerical. A zero is inserted in position 718. The preset word mark in that position stops the insertion of additional zeros in the unit cost expanded field. In a similar way, the 0475C part number moves from positions 711-715 to positions 713-717, and zeros are inserted in positions 712 and 711, halted by the word mark in location 711. The Δ in position 710 indicates the units position of the next field (part name).

The Δ changes the setting of the mode change switch from numerical to alphabetic. In the alphabetic mode, characters are moved without insertion of zeros.

The expanded area in core storage after the operation looks like this:

EXTbbSHANKΔ000475C01154E‡

Note: To conserve storage, the compressed area overlaps with the expanded area in this example.

Column Binary Feature

This feature makes it possible for the IBM 1401 Data Processing System to process column-binary-coded cards and magnetic tapes used with IBM scientific data processing systems such as the IBM 704, IBM 709, and IBM 7090.

The reading, writing, and logic operational facilities of the 1401 can be used to process the binary-coded data.

The operation codes and instructions described in this section are used whenever:

1. The information to be read or written is in binary cards or binary coded tapes.
2. There are invalid multiple punches in cards containing the standard IBM card code. This means that cards, coded with several punches in one column, that were designed for other machines can be entered by using this feature.

Read Column Binary

Instruction Format.

Mnemonic	Op Code	d-character
SPS R	<u>1</u>	C
A RCB		

Function. This instruction causes the card at the read station to be read into the 1401 in the binary mode. During the reading of a card, the read cycle is

divided into two parts, and three different areas in storage receive the data. Card cycle 9 through 4 time uses the normal read addresses 001-080, and column binary read area addresses 501-580. The other portion of the card cycle (3-12 time) uses addresses 001 through 080, and 401 through 480. Note that storage locations 001-080 are common read-in locations for both halves of the read cycle.

At the completion of this read operation, a BCD coded image of the card is stored in addresses 001 through 080, just as in normal card reading. The portion of the card that contains column-binary information appears as *hash* in the corresponding addresses 001-080, and the portion of the card that contained alphanumerical characters is stored in BCD code in addresses 001 through 080. Storage addresses 401-480 and 501-580 contain the true card image. In these areas all alphanumerical characters and all column-binary information appear as illustrated in Figure 160 :

If, for example, the following information is recorded in a binary card and appears in 1401 storage:

Card-column 1 contains an IBM card code H which is represented by a 12-punch and an 8-punch.

<i>Storage Locations</i>	<i>Contains</i>
001	BA8
401	B
501	2

	BCD CODE	PUNCHES IN CARD COLUMN
Storage	C	
	B	12
	A	11
Addresses	8	0
	4	1
	2	2
401-480	1	3

	Storage	C
B		4
A		5
Addresses	8	6
	4	7
	2	8
501-580	1	9

	Storage	C
B		11
A		0
Addresses	8	1
	4	2
	2	3
001-080	1	4
	(BCD equivalent of the card	5
	punches if alphanumerical,	6
hash if true binary.)	7	
	8	
	9	

Figure 160. BCD Code and Column Binary Punches

Card-column 2 is part of a binary field and contains punches in rows 12, 0, 1, 3, 4, 5, 6, 7, and 9.

<i>Storage Locations</i>	<i>Contains</i>
002	hash
402	CB841
502	BA841

Word Marks. Word marks are not affected.

Timing. $T = .0115 (L_I + 1) \text{ ms} + \text{I/O}$.

Notes. The READ COLUMN BINARY instruction (1C) cannot be combined with any other operation.

Read checking of input data is unchanged, except for the validity check, which is not performed because all characters read are considered valid.

Address Registers After Operation.

<i>I-Add. Reg.</i>	<i>A-Add. Reg.</i>	<i>B-Add. Reg.</i>
NSI	dbb	481

Example. Read the card at the IBM 1402 read station in the column binary mode (Figure 161).

LINE	COUNT	LABEL	OPERATION	(A) OPERAND				(B) OPERAND				d	
				ADDRESS	CHAR. ADJ.	ADDRESS	CHAR. ADJ.	ADDRESS	CHAR. ADJ.				
1	0		R										

Autocoder									
Label	Operation	OPERAND							
5	15	20	25	30	35	40	45	50	55
	RCB								

Assembled Instruction: 1 C

Figure 161. Read Column Binary

Read Column Binary and Branch

Instruction Format.

<i>Mnemonic</i>	<i>Op Code</i>	<i>I-address</i>	<i>d-character</i>
SPS R	<u>1</u>	xxx	C
A RCB			

Function. This is the same as READ COLUMN BINARY, except that the next instruction is at the I-address.

Word Marks. Word marks are not affected.

Timing. $T = .0115 (L_I + 1) \text{ ms} + \text{I/O}$.

Address Registers After Operation.

<i>I-Add. Reg.</i>	<i>A-Add. Reg.</i>	<i>B-Add. Reg.</i>
NSI	BI	481

Example. Read the card at the read station in column binary mode, and branch to BININ (0922) for the next instruction (Figure 162).

SPS			(A) OPERAND					(B) OPERAND					d			
LINE	COUNT	LABEL	OPERATION	ADDRESS	±	CHAR. ADJ.	IN	ADDRESS	±	CHAR. ADJ.	IN	34	35	36	39	
3	8	7	9	13	14	16	17									
																C
0	1	0														

Autocoder			OPERAND													
Label	Operation	15	16	20	21	25	30	35	40	45	50					

Assembled Instruction: 1 922 C

Figure 162. Read Column Binary and Branch

SPS			(A) OPERAND					(B) OPERAND					d			
LINE	COUNT	LABEL	OPERATION	ADDRESS	±	CHAR. ADJ.	IN	ADDRESS	±	CHAR. ADJ.	IN	34	35	36	39	
3	8	7	9	13	14	16	17									
																C
0	1	0														

Autocoder			OPERAND													
Label	Operation	15	16	20	21	25	30	35	40	45	50					

Assembled Instruction: 4 C

Figure 163. Punch Column Binary

Punch Column Binary

Instruction Format.

Mnemonic	Op Code	d-character
SPS P	<u>4</u>	C
A PCB		

Function. This instruction, executed in two parts, requires that the information be stored in two different areas. Information that is to be punched in rows 12-3 (card columns 1-80) is stored in locations 401-480. Rows 4-9 of the card (columns 1-80) are punched from storage locations 501-580.

Using the same data shown in the READ COLUMN BINARY example, the card is punched:

Storage Locations	BCD	Punches
401	B	12
501	2	8

This combination causes the H to punch in card column 1.

Card column 2 is punched in rows 12, 0, 1, 3, 4, 5, 6, 7, and 9 as transferred from:

Storage Locations	BCD	Punches
402	CB841	12, 0, 1, 3
502	BA841	4, 5, 6, 7, 9

Word Marks. Word marks are not affected.

Timing. $T = .0115 (L_I + 1) \text{ ms} + \text{I/O}$.

Note. The PUNCH COLUMN BINARY instruction cannot be combined with any other operation. The punch checking of output data is unchanged.

Address Registers After Operation.

I-Add. Reg.	A-Add. Reg.	B-Add. Reg.
NSI	dbb	181

Example. Punch the card at the punch station in the column binary mode (Figure 163).

Punch Column Binary and Branch

Instruction Format.

Mnemonic	Op Code	I-address	d-character
SPS P	<u>4</u>	xxx	C
A PCB			

Function. This is the same as the PUNCH COLUMN BINARY instruction, except that the next instruction is taken from the I-address.

Word Marks. Word marks are not affected.

Timing. $T = .0115 (L_I + 1) \text{ ms} + \text{I/O}$.

Note: The PUNCH COLUMN BINARY AND BRANCH instruction cannot be combined with any other operation. The punch checking of output data is unchanged.

Address Registers After Operation.

I-Add. Reg.	A-Add. Reg.	B-Add. Reg.
NSI	BI	181

Example. Punch a card in the column binary mode, and branch to BINCD (0986) for the next instruction (Figure 164).

SPS			(A) OPERAND					(B) OPERAND					d			
LINE	COUNT	LABEL	OPERATION	ADDRESS	±	CHAR. ADJ.	IN	ADDRESS	±	CHAR. ADJ.	IN	34	35	36	39	
3	8	7	9	13	14	16	17									
																C
0	1	0														

Autocoder			OPERAND													
Label	Operation	15	16	20	21	25	30	35	40	45	50					

Assembled Instruction: 4 986 C

Figure 164. Punch Column Binary and Branch

Branch if Bit Equal

Instruction Format.

Mnemonic	Op Code	I-address	B-address	d-character
BBE	W	xxx	xxx	x

Function. The d-character can contain any character or any combination of bits (BA 8421) that can exist in a single position of the 1401 core storage. If the character at the B-address contains any bit that matches any bit in the d-character, the program branches to the I-address. Otherwise, the program continues normally.

Word Marks. Word marks are not affected.

Timing. $T = .0115 (L_I + 2)$ ms.

Address Registers After Operation.

I-Add. Reg.	A-Add. Reg.	B-Add. Reg.
NSI	BI	B-1

Example. Examine the storage location labeled UNPOS (0759) for a match in the d-character bit configuration. The d-character is a 9 (8- and 1-bits). Therefore, if the character contains either an 8- or 1-bit, the program branches to BITEST (0985), Figure 165.

SPS			(A) OPERAND				(B) OPERAND			
LINE	COUNT	LABEL	OPERATION	ADDRESS	CHAR. ADA.	ADDRESS	CHAR. ADA.	d		
3	6	7	13	16	17	23	26	27		
0	1	0	BBE	BITEST		UNPOS		9		

Autocoder			OPERAND			
Label	Operation	Address	Char. Ada.	Address	Char. Ada.	d
5	15	20	21	25	30	35
	BBE	BITEST		UNPOS		9

Assembled Instruction: W 985 759 9

Figure 165. Branch on Bit Test

Binary Tape Instructions

Column-binary information should be recorded on magnetic tape in its logical order. To do this it is necessary to arrange the data from storage locations 401-480 and 501-580 in the following sequence in a tape write area:

Address 401 followed by 501, followed by 402, 502, etc., until the entire area is so arranged.

This puts the 12-3 data next to the 4-9 data from the same card column, in the proper sequence for writing on tape.

This arranging can be done automatically by a MOVE AND BINARY DECODE instruction.

Conversely data read from a tape unit can be arranged as a card image with 12-3 punches in the 401-

480 area and 9-4 punches in the 501-580 area. The MOVE BINARY CODE operation performs this function.

Column-binary information must be written on magnetic tape in the odd-parity mode. This means that an odd number of bits must be recorded in each position of the tape record. The WRITE BINARY TAPE and READ BINARY TAPE instructions cause the data to be recorded in this manner.

Move and Binary Decode

Instruction Format.

Mnemonic	Op Code	A-address	B-address	d-character
SPS MCW	M	xxx	xxx	A
A MBD				

Function. This instruction arranges data in the correct order for tape writing. The A-address is usually 572 or 580, depending on whether the card has 72 or 80 columns of binary data. It specifies the units or low-order position of the record. The B-address specifies the low-order position of the area in 1401 storage from which the record is to be written on tape by a WRITE BINARY TAPE instruction. The d-character specifies that this is a move and binary decode operation.

At the completion of this operation, the tape-write area (B-address) contains the data from both the 401-480 and 501-580 areas in this sequence:

401, 501, 402, 502, 403, etc.

Word Marks. A word mark must be preset in the 401-480 area to signify the high-order character of the record (normally in location 401). Any word-mark encountered stops the transfer to the tape-write area.

Timing. $T = .0115 (L_I + 1 + 2L_B)$ ms.

Address Registers After Operation.

I-Add. Reg.	A-Add. Reg.	B-Add. Reg.
NSI	Address of the 400 area preset word mark + 99.	B-L _B

Example. Write the data in 401-480 (labeled CLBI4A) and 501-580 (labeled CLBI5A) areas in the tape-write area labeled BITPAR (2080), Figure 166.

SPS			(A) OPERAND				(B) OPERAND			
LINE	COUNT	LABEL	OPERATION	ADDRESS	CHAR. ADA.	ADDRESS	CHAR. ADA.	d		
3	6	7	13	16	17	23	26	27		
0	1	0	MCW	CLBI4A		BITPAR		A		

Autocoder			OPERAND			
Label	Operation	Address	Char. Ada.	Address	Char. Ada.	d
5	15	20	21	25	30	35
	MBD	CLBI5A		BITPAR		A

Assembled Instruction: M 580 180 A

Figure 166. Move and Binary Decode

Move Binary Code

Instruction Format.

Mnemonic	Op Code	A-address	B-address	d-character
SPS MCW	<u>M</u>	xxx	xxx	B
A MBC				

Function. Information read from magnetic tape is arranged into a coded card image in binary form, when this instruction is used. Data to be punched in rows 12-3 is transferred to IBM 1401 storage area locations 401-480, and data to be punched in rows 4-9 is stored in the 501-580 area for punching. The A-address specifies the units position of the tape read-in area, and the B-address is usually 572 or 580, depending on the number of columns to be punched. The d-character (B) specifies a move binary code operation.

Word Marks. A word mark must be preset in the high-order position of the B-field (normally 401) to stop the operation.

A word mark in the high-order position of the A-field can be set to stop the operation after the following B-cycle if desired.

Timing. $T = .0115 (L_I + 1 + 2L_B)$ ms.

Address Registers After Operation.

I-Add. Reg.	A-Add. Reg.	B-Add. Reg.
NSI	A-L _A	The address of the preset word mark in the 400 area + 99.

Example. Move the data from the tape read-in area, labeled BITPAR (2080), to the column-binary punch area CLBI4A (0401-0480) and CLBI5A (0501-0580), and store it in the proper sequence for punching (Figure 167).

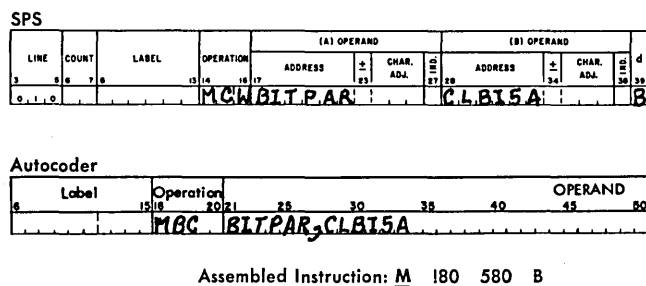

Figure 167. Move and Binary Code

Write Binary Tape

Instruction Format.

Mnemonic	Op Code	A-address	B-address	d-character
SPS MU	<u>M</u>	%Bx	xxx	W
A WTB				

Function. This instruction writes a tape record in the odd-parity mode. The A-address specifies the

tape unit to be selected, and signals that this is a column binary tape operation. The B-address specifies the high-order position of the tape record in 1401 storage. The d-character indicates a tape write operation. The sensing of a group-mark, with a word-mark in 1401 storage stops transmission from the 1401 to the tape unit.

Word Marks. Word marks are not affected.

Timing. $T = .0115 (L_I + 1)$ ms + T_M .

Address Registers After Operation.

I-Add. Reg.	A-Add. Reg.	B-Add. Reg.
NSI	%2x	Group-mark + 1

Example. Write a tape record in the binary mode on the tape unit labeled 4, with the data stored in the area labeled BTPOUT (2001) and ending at the group-mark with a word-mark sensed in 1401 core storage (Figure 168).

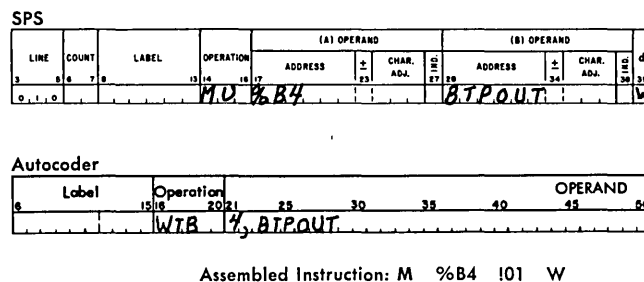

Figure 168. Write Tape Binary

Read Binary Tape

Instruction Format.

Mnemonic	Op Code	A-address	B-address	d-character
SPS MU	<u>M</u>	%Bx	xxx	R
A RTB				

Function. A tape record written in binary form is read into core storage, beginning at the location specified by the B-address and ending at an inter-record gap between tape records or a group-mark with a word-mark in core storage. The A-address indicates the tape unit selected, and signals the column-binary tape operation. The d-character (R) specifies a read operation.

Word Marks. Word marks are not affected.

Timing. $T = .0115 (L_I + 1)$ ms + T_M .

Address Registers After Operation.

I-Add. Reg.	A-Add. Reg.	B-Add. Reg.
NSI	%2x	Group-mark + 1

Example. Read the binary tape record from the tape unit labeled 5 into the area of 1401 core storage labeled BTPIN (2080) and ending at the group-mark with a word-mark sensed in core storage or at the first inter-record gap encountered in the tape record (Figure 169).

SPS

LINE	COUNT	LABEL	OPERATION	(A) OPERAND				(B) OPERAND				
				ADDRESS	±	CHAR. ADJ.	±	ADDRESS	±	CHAR. ADJ.	±	
0	1	0	MU	%B5				BTPIN				

Autocoder

Label	Operation	OPERAND									
RTB	5	BTPIN									

Assembled Instruction: M %B5 180 R

Figure 169. Read Tape Binary

Numerical Print Feature

The numerical print feature for the IBM 1403 Printer has been designed for those businesses having certain 1401 applications that require no alphabetic printing. For example, banks, insurance companies, and utilities prepare many reports with only numerical printing. With this feature, the time required to produce these reports can be reduced by as much as 50 per cent. The manufacturing, wholesaling, and retailing levels of other industries can also use this feature for the many applications in which reports are (or can be) numerically coded.

With this feature, the systems user can switch from the alphanumerical to the numerical mode, simply by changing the chain cartridge in the 1403. The numerical chain is composed of 15 character sets, with 16 characters (digits 0 through 9 \$. , * - □) in each set. In the numerical mode, the 1403 can print 1285 lines per minute – more than twice as fast as in the alphanumerical mode.

To change from one mode to another, an operator, with no special tools, removes one chain and replaces it with the other. Before locking the new cartridge in place, it is only necessary to move the chain enough to permit the chain drive to engage. When a chain cartridge is placed in the 1403, the corresponding mode is selected automatically. If the printer is in the numerical mode, characters other than the 16 specified for numerical printing cause a print check error.

Interchangeable Chain Cartridge Adapter

Many scientific and commercial applications require distinctive type styles for particular printing jobs. This special feature for the IBM 1403 Printer allows chain cartridges to be interchanged.

With this feature, an operator can insert an interchangeable chain cartridge with a different type font, type style, or special character arrangement.

Operating Instructions

1. Turn off the power in the system.
2. Raise the counterbalanced cover of the printer.
3. Unlock and swing back the print unit by using the print unit release lever.
4. Open the top ribbon cover, remove the lower ribbon roll, slide ribbon from under the ribbon correction roll and store the lower ribbon roll on the ribbon cover.
5. Grasp the chain cartridge handles and raise them to a vertical position. This unlocks the cartridge from the print unit.
6. Lift straight up on the cartridge handles until the cartridge clears the locating pins. Place the cartridge on a surface that tolerates oil and ink. (A container is provided for storing the chain cartridge when it is not in use.)
7. Install the second cartridge by grasping the handles and lifting the cartridge into position over the locating pins. Check the bottom of cartridge for foreign material before placing it on the printer.
8. Position the cartridge gently over its guide pins and release the handles. *Do not force either handle down.* The end opposite print hammer 132 should fully settle on the base, the end opposite hammer unit 1 is not in position at this time.
9. Rotate the chain in the normal printing direction (counterclockwise as seen from the top), and at the same time press down on the button located on the top cover between the chain cartridge position and the print-timing dial. When you can no longer rotate the chain, it is properly positioned at the end opposite hammer number one.
10. Lower the chain cartridge handles to their horizontal positions. *Do not force* the handles. If force is required, the chain is not properly in position and steps 7 through 9 should be repeated.
11. Replace the lower ribbon roll and make sure the ribbon is positioned under the ribbon correction roll. Close the ribbon shield, latch the print unit in place, and close the counterbalanced cover. Turn the power on and resume system operation.

Interchangeable 51-Column Read Feed

The interchangeable 51-column read feed (including file feed) permits feeding either 51-column cards or standard 80-column cards in the read feed of the IBM 1402 Card Read-Punch.

The 51-column card is commonly used for charge sales slips, postal money-order forms, installment payments, inventory cards, and many other applications.

Using an interchangeable feed allows direct entry to the data processing system from the stub card. This eliminates the need for reproducing 51-column cards into standard 80-column cards.

To adapt the read feed for 51-column-card operation, the operator installs a tray and hopper side plates on the read file feed, and adjusts the stackers on the read side.

Normal operations of the IBM 1402 Card Read-Punch can be performed with 51-column cards in the read feed. For example, a file of 51-column cards can be processed in the read feed while the results are

punched in 80-column cards in the punch feed. However, when the stackers are adjusted to accept 51-column cards, no cards from the read feed can be *selected* into stacker 8/2.

Machine Features

Modifying the read file feed and stackers readily adapts the IBM 1402 Card Read-Punch for processing 51-column cards.

MODIFYING THE FILE FEED

An *adapter tray* (Figure 170), placed on the file-feed magazine, accommodates the 51-column cards. A modified card weight enables feeding the last cards from the hopper. Inserting two *hopper side plates* (Figure 170) positions the 51-column cards at the center of the feed. Thumbscrews fasten the side plates to the hopper. Jugglers align the cards in the hoppers, as in standard operation.

In 51-column-card operation, the first column of the card corresponds to column 15 of an 80-column card,

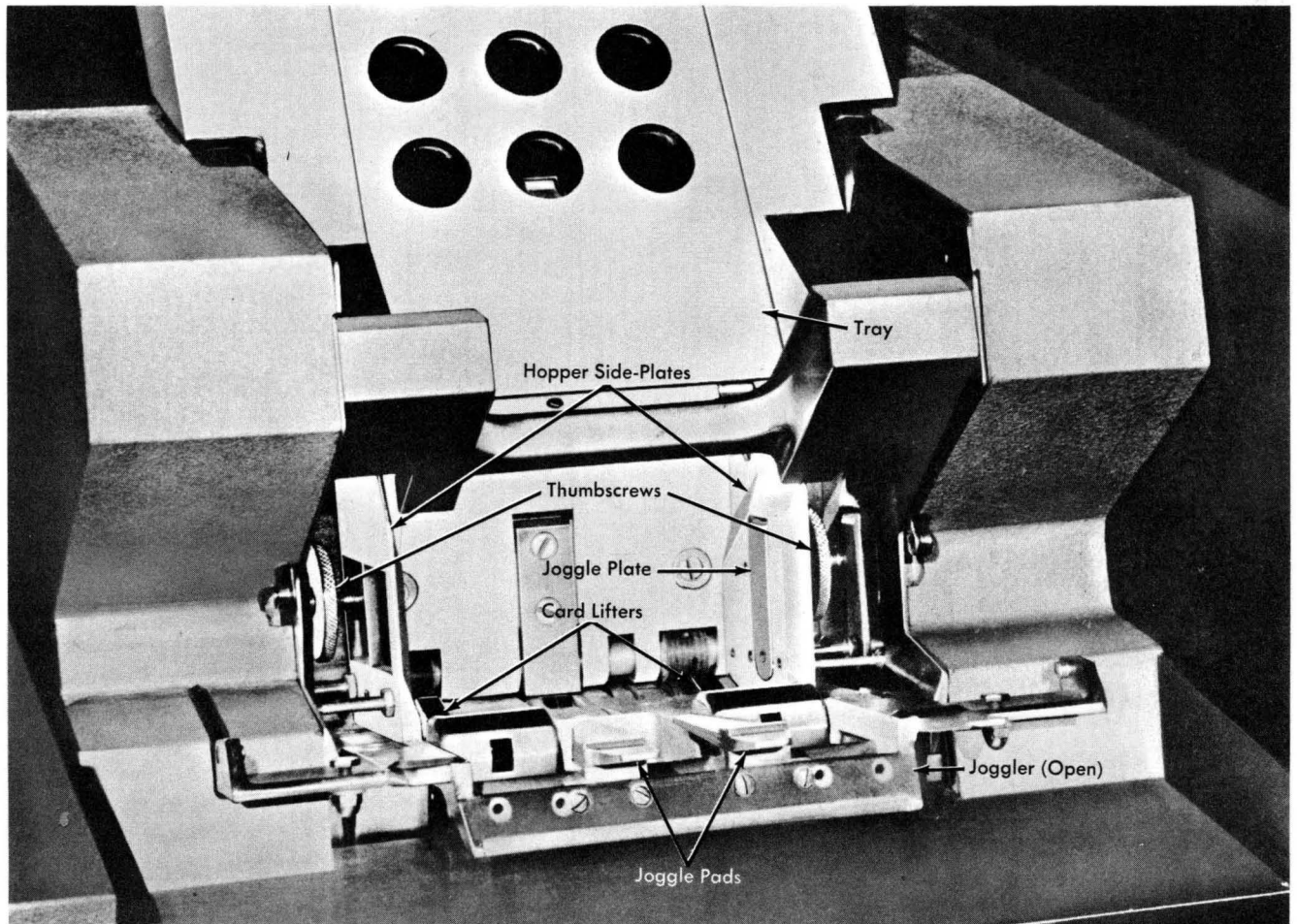

Figure 170. Interchangeable 51-Column Read Feed

and is therefore read by brush 15; the last column corresponds to column 65 and is read by brush 65. A factor of 14 relates the card column to the reading brush. A switch for regulating the storing of information from a 51-column card is physically located in the 1402. It is automatically turned on when the stacker guide is pulled forward for stacking of 51-column cards.

When the switch is on, the information from a 51-column card is read into the read-in area of storage beginning in position 015 and extending to position 065. Positions 001-013 and 066-080 are not altered during a 51-column operation. Position 014 is used for cycle timing.

This switch provides for the proper loading of instructions from 51-column cards when the load key is used. With the switch on, pressing the load key causes a word mark to be set in storage position 015 and automatically clears position 016 to 065 of word marks and places 015 in the I-address register. It should be noted that a factor of 14 must be added to the read-in area addresses.

ADJUSTING THE SECONDARY STACKERS

The operator adjusts the stacker guide (Figures 171 and 172) at the rear of stackers NR and 1 to accommodate 51-column cards. A finger hole permits pulling the guide forward to reduce the depth of the stacker. A spring latch holds the guide securely in either the 51- or 80-column-card position.

A *pivot-plate* assembly (Figures 171 and 172) adapts the front of stackers NR and 1 for stacking either 51- or 80-column cards. The 51-column pivot plate with card-retaining levers swings down and fastens to the stacker separators. This assembly provides a lower pivot for properly stacking the 51-column cards.

For standard 80-column operation, the operator pulls each auxiliary pivot-plate assembly forward and then places it under the cover.

Modified *card-deck supports* (Figures 171 and 172) for stackers NR and 1 permit stacking 51-column cards, standard cards, and the scored cards processed by the machine. The capacity of each of these stackers is 800 cards.

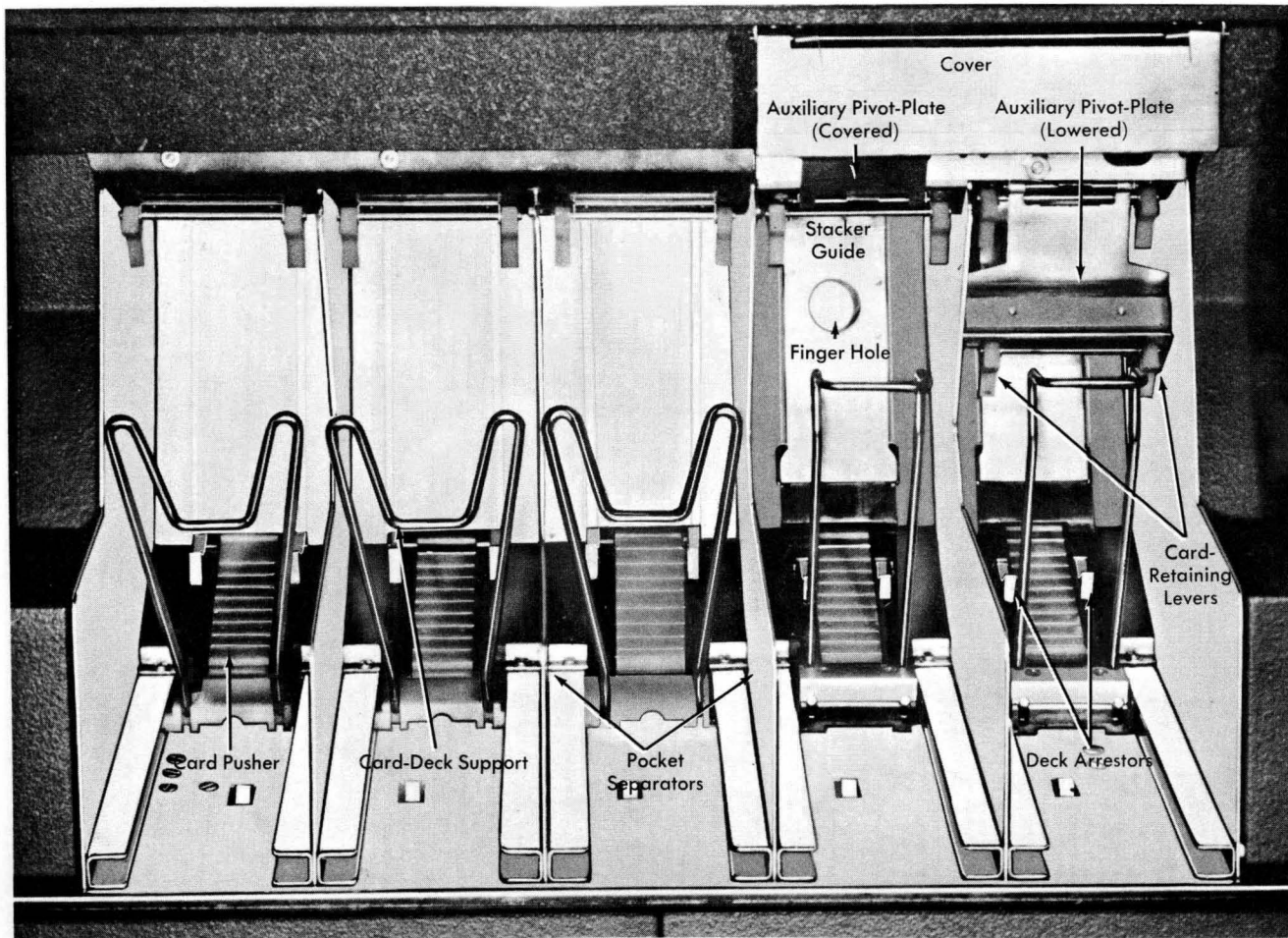

Figure 171. 51-Column Adjustable Stackers

Page 96 -- Add the following text before the last paragraph in the left column:

Left-scored, 51-column cards must not contain punches in the columns that are the equivalent to columns 28 and 29 of an 80-column card. If these columns are punched, misfeeding of cards may occur. The first punch in a 51-column card may be in the column equivalent to column 30 of an 80-column card.

When changing from 51-column to 80-column operation, a few blank 80-column cards should be run through the read feed to ensure that the card transport is clear.

SETUP OPERATION

To set up the IBM 1402 Card Read-Punch to feed 51-column cards in the read feed:

1. Position the side plates in the hopper, and fasten firmly by turning the knurled thumbscrews. Be careful not to interfere with the card lifters.
2. Place the 51-column-card tray over the file-feed magazine.
3. Reach into stackers NR and 1 and, using the finger hole, pull the guide forward until it latches.
4. Raise the cover over the auxiliary pivot-plate assemblies, lower one assembly partially, and then slide the main pivot-plate to the rear until it latches.
5. Swing the auxiliary pivot-plate assembly down until it latches to the stacker separators. (Repeat steps 4 and 5 for the other pivot-plate assembly.)

Reverse this procedure to return to standard card-feeding. *Note:* Handle and store the adapter tray and hopper side plates carefully to avoid damaging them.

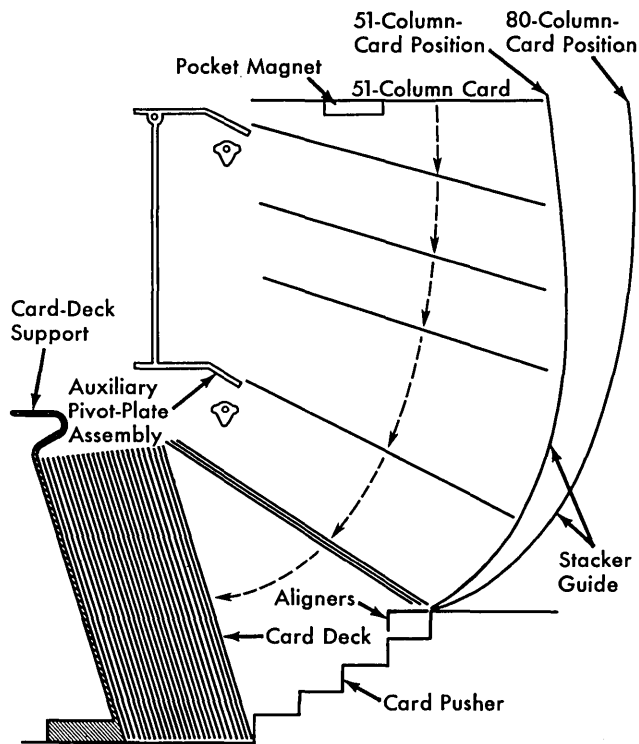

Figure 172. 51-Column Stacker Schematic

Early Card Read Feature

The early card read feature for the IBM 1402 Card Read-Punch minimizes the decrease in card-reading speed caused by lengthy processing routines. In such

routines, the card-reading mechanism can engage sooner, thus reducing the time between the reading of cards.

Normally, if processing time exceeds 10 ms in a basic card-read cycle, the rated card-reading speed decreases. This occurs because of the mechanical structure of the card-read feed. There is only one time during the read cycle when the feeding mechanism can be engaged. If a READ A CARD instruction is given too late (processing time exceeds 10 ms), a card-read cycle is skipped, thus reducing the input speed from 800 to 400 cards per minute. Similarly, if the time required for processing exceeds 85 ms, two read cycles are skipped, and the input speed is reduced to 266 cards per minute.

The early card read feature provides two additional points (clutch points) where the feeding mechanism can engage. When processing time between cards exceeds 10 ms, the feed mechanism can engage 50 ms sooner than before. The time between card feeding, is reduced to 100 ms rather than 150 ms. Instead of a 50 per cent reduction in the rated speed (to 400 cpm), there is only a reduction of 25 per cent (to 600 cpm). See section on *Timing*.

Processing Overlap Feature

The processing overlap special feature for the IBM 1401 Data Processing System provides, for many applications, great reductions in over-all job time. The high-speed processing and input-output abilities of the 1401 now can be used with maximum efficiency. Jobs requiring extensive input-output operations and lengthy programming now can be performed at or near maximum speeds. The actual increase in efficiency and consequent saving in job time varies with the specific program, and depends on the input-output requirements of the particular application.

The processing overlap feature allows processing to be interrupted in order to take input-output cycles. A character can be read, written, or punched between processing cycles.

Serial input-output devices used with the IBM 1401 Data Processing System, such as the IBM 1011 Paper Tape Reader and the IBM 1419 Magnetic Character Reader, can have their operations performed in overlap mode. In some cases, entire input-output operations can be overlapped; in others, partial overlapping can occur.

Job time required for card input-output applications is reduced because the processing operation is not interlocked during card reading or punching. This is

also true when reading or writing magnetic tape. Tape operations and processing can occur on alternate cycles. This ability can result in appreciable increase in job time economy.

The processing overlap special feature makes the IBM 1401 Data Processing System a more powerful tool for use in the field of data processing.

Data Flow

The overlap special feature requires the addition of an O-register and an O (overlap)-address register to the processing unit (Figure 173). These registers function in much the same manner as the A- and B-registers and the I-, A-, and B-address registers. That is, the O-register is used for movement of data when operating with an I/O unit. The O-address register is used to keep track of the location of data that is moved by an I/O operation. These registers, when used by the program, operate on alternate cycles with the normal registers. Thus the 1401 takes processing cycles and then an input-output cycle, when required, instead of

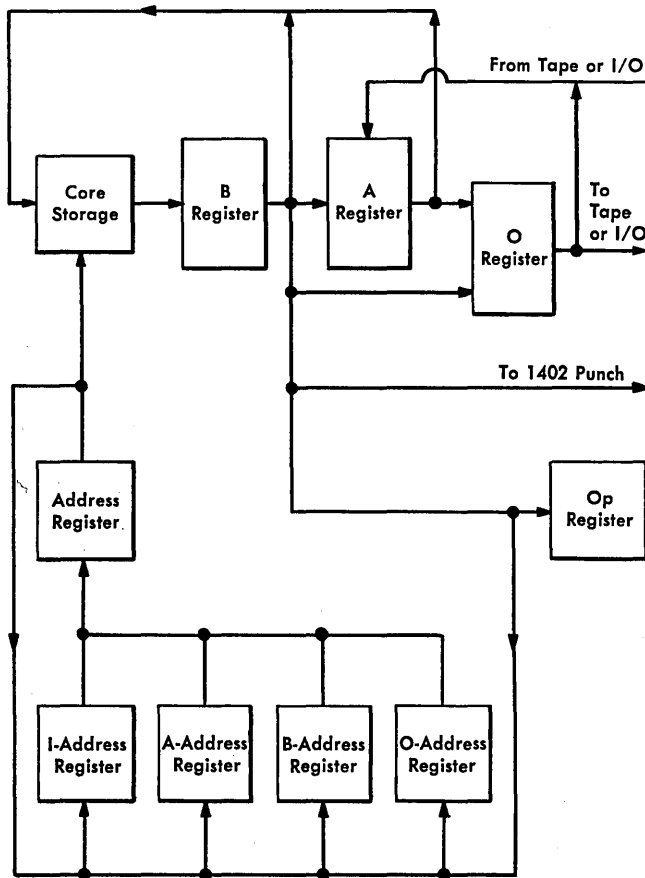

Figure 173. IBM 1401 Processing Overlap Data Flow

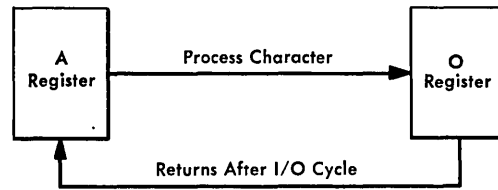

Figure 174. IBM 1402, Overlap Operation

interlocking processing while an input-output operation is being performed. This means a savings in overall job time.

IBM 1402 Card Read-Punch

When the system is in the overlap mode, processing can occur during the card cycle in which data is read from, or punched into, a card. Processing does not occur during the time used for either read or punch scanning, but alternates with scanning.

At the beginning of each read or punch scan, the character in the A-register is sent to the O-register (Figure 174) and the O-address register is set at the column being scanned. When the read or punch scan of the character is completed, the character in the O-register is sent back to the A-register. At this point processing resumes.

Tape Operations

During a read operation, data from magnetic tape enters the A-register and then moves into core storage. During an overlapped read operation, data necessary for processing is contained in the A-register. In order to save the data, it is sent to the O-register until recalled for the next processing cycle, before data is read in from tape to the A-register (Figure 175). The O-address register contains the storage address in which the data

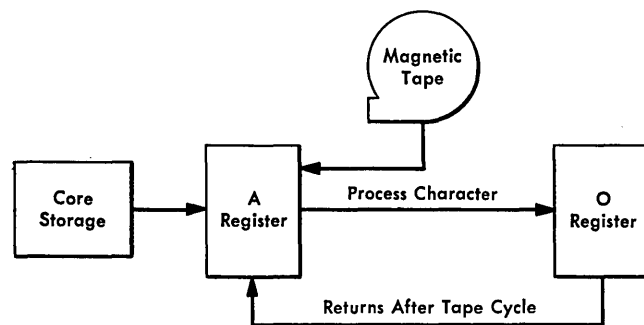

Figure 175. Overlapped Read Magnetic-Tape Operation

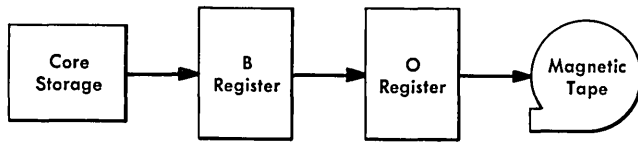

Figure 176. Overlapped Write Magnetic-Tape Operation

being read from magnetic tape is to be stored, at the same time that the I-, A-, and B-address registers keep track of the processing operation being performed.

During a *write* operation, data from core storage passes through the B-register and enters the O-register (Figure 176). It is sent to magnetic tape from the O-register. Processing cycles use the A- and B-register. The O-address register contains the storage address of the data being written on magnetic tape. At the same time the I-, A-, and B-address registers keep track of the processing operation being performed.

To store the contents of the O-address register at the end of an overlapped tape operation the following operations must be performed:

B (xxx) J BRANCH IF TAPE BUSY INDICATOR ON.
 This instruction allows the contents of the O-address register to be transferred to the B-address register (with the advanced programming feature) if the indicator is not ON.

Then

H xxx Store B-address register

Other Input-Output Units

Input-output units such as the IBM 1419 Magnetic Character Reader, when operating in the overlap mode, function in the same manner as a magnetic tape unit. Overlapping and processing occurs just as if the operation were a tape read or write operation.

Processing Overlap Instructions

To signal the 1401 that an operation to be performed should be done in the overlap mode, special instructions and A-address changes must be used in the program.

A-ADDRESS

The hundreds position of the A-address of a tape or input-output unit (not 1405 or 1407) instruction is changed from % to @. The @ (at) symbol signals the 1401 processing unit that the operation to be performed should be done as an overlap operation. The

@ symbol can be used to signal an overlap operation with the:

- IBM 1011 Paper Tape Reader
- IBM 1419 Magnetic Character Reader
- IBM 729 II, IV, V Magnetic Tape Unit
- IBM 7330 Magnetic Tape Unit

Overlap On

Instruction Format.

Mnemonic Op Code d-character
 SS K \$

Function. This instruction sets the 1401 processing unit in the overlap mode. All 1402 read, punch, and combination card instructions that follow this instruction in the program are performed in the overlap mode.

Word Marks. Word marks are not affected.

Timing. $T = .0115 (L_1 + 1)$ ms.

Address Registers After Operation.

I-Add. Reg. A-Add. Reg. B-Add. Reg.
 NSI dbb dbb

Example. Set the 1401 in the overlap mode (Figure 177).

LINE	COUNT	LABEL	OPERATION	(A) OPERAND				(B) OPERAND				d		
				ADDRESS	±	CHAR. ADJ.	IND.	ADDRESS	±	CHAR. ADJ.	IND.			
3	8	7	SS	15	16	17								

Label	Operation	OPERAND			
6	15 16 20 21	25	30	35	40 45 50
SS	SS				

Assembled Instruction: K \$

Figure 177. Overlap On

Overlap On and Branch

Instruction Format.

Mnemonic Op Code I-address d-character
 SPS SS K xxx \$
 A SSB

Function. This is the same as OVERLAP ON, except that the next instruction is taken from the I-address.

Word Marks. Word marks are not affected.

Timing. $T = .0115 (L_1 + 1)$ ms.

Address Registers After Operation.

I-Add. Reg. A-Add. Reg. B-Add. Reg.
 NSI BI dbb

Example. Set the 1401 in the overlap mode and branch to CDROUT (0950) for the next instruction (Figure 178).

SPS				(A) OPERAND				(B) OPERAND			
LINE	COUNT	LABEL	OPERATION	ADDRESS	CHAR. ADJ.	HE	ADDRESS	CHAR. ADJ.	HE	d	
5	8	7	6	13	14	16	17	23	24	26	27
0	1	0	0	0	0	0	0	0	0	0	0
			SS	C.D.R.O.U.T							

Autocoder		OPERAND			
Label	Operation	25	30	35	40
	SS	C.D.R.O.U.T			

Assembled Instruction: K 950 \$

Figure 178. Overlap On and Branch

Overlap Off

Instruction Format.

Mnemonic Op Code d-character
 SS K .

Function. This instruction returns the 1401 processing unit to normal operation. All card input-output instructions following this instruction are performed without the overlap feature.

Word Marks. Word marks are not affected.

Timing. $T = .0115 (L_I + 1)$ ms.

Address Registers After Operation.

I-Add. Reg. A-Add. Reg. B-Add. Reg.
 NSI dbb dbb

Example. Place 1401 in normal operation (Figure 179).

SPS				(A) OPERAND				(B) OPERAND			
LINE	COUNT	LABEL	OPERATION	ADDRESS	CHAR. ADJ.	HE	ADDRESS	CHAR. ADJ.	HE	d	
5	8	7	6	13	14	16	17	23	24	26	27
0	1	0	0	0	0	0	0	0	0	0	0
			SS								

Autocoder		OPERAND			
Label	Operation	25	30	35	40
	SS				

Assembled Instruction: K •

Figure 179. Overlap Off

Overlap Off and Branch

Instruction Format.

Mnemonic Op Code I-address d-character
 SPS SS K XXX •
 A SSB

Function. This instruction is the same as OVERLAP OFF, except that the next instruction is taken from the I-address.

Word Marks. Word marks are not affected.

Timing. $T = .0115 (L_I + 1)$ ms.

Address Registers After Operation.

I-Add. Reg. A-Add. Reg. B-Add. Reg.
 NSI BI dbb

Example. Place the 1401 in normal operation, and branch to the routine labeled NORCRD (1771) for the next instruction (Figure 180).

SPS				(A) OPERAND				(B) OPERAND			
LINE	COUNT	LABEL	OPERATION	ADDRESS	CHAR. ADJ.	HE	ADDRESS	CHAR. ADJ.	HE	d	
5	8	7	6	13	14	16	17	23	24	26	27
0	1	0	0	0	0	0	0	0	0	0	0
			SS	NORCRD							

Autocoder		OPERAND			
Label	Operation	25	30	35	40
	SS	NORCRD			

Assembled Instruction: K X71 •

Figure 180. Overlap Off and Branch

Reset Overlap

Instruction Format.

Mnemonic Op Code d-character
 SS K □

Function. This instruction is only operative when the serial input-output adapter special feature is installed. If the system is performing an overlapped serial I/O operation when this instruction is given, the I/O device is disconnected from the system and the following indicators are turned ON: I/O error (d-character 1), and tape transmission error (d-character L).

Word Marks. Word marks are not affected.

Timing. $T = .0115 (L_I + 1)$ ms.

Note. If an overlap tape operation is in process when this instruction is given, the tape unit is disconnected and the tape transmission error indicator is turned ON.

Address Registers After Operation.

I-Add. Reg. A-Add. Reg. B-Add. Reg.
 NSI dbb dbb

Example. Reset overlap mode and return 1401 to normal operation (Figure 181).

SPS				(A) OPERAND				(B) OPERAND			
LINE	COUNT	LABEL	OPERATION	ADDRESS	CHAR. ADJ.	HE	ADDRESS	CHAR. ADJ.	HE	d	
5	8	7	6	13	14	16	17	23	24	26	27
0	1	0	0	0	0	0	0	0	0	0	0
			SS								

Autocoder		OPERAND			
Label	Operation	25	30	35	40
	SS				

Assembled Instruction: K □

Figure 181. Reset Overlap

Reset Overlap and Branch

Instruction Format.

Mnemonic	Op Code	I-address	d-character
SPS SS	<u>K</u>	xxx	□
A SSB			

Function. This instruction is the same as RESET OVERLAP, except that the next instruction is taken from the I-address.

Word Marks. Word marks are not affected.

Timing. $T = .0115 (L_I + 1)$ ms.

Address Registers After Operation.

I-Add. Reg.	A-Add. Reg.	B-Add. Reg.
NSI	BI	dbb

Example. Reset overlap mode and branch to routine labeled NORMOP (1755) for the next operation (Figure 182).

LINE		COUNT	LABEL	OPERATION	(A) OPERAND				(B) OPERAND				d										
3	2	1	13	14	15	16	17	18	19	20	21	22	23	24	25	26	27	28	29	30	31	32	
0	1	0		SS	1755																		
NORMOP																							

Label		Operation	OPERAND									
6	5	15	16	20	21	25	30	35	40	45	50	
SSA		NORMOP										

Assembled Instruction: K X55 □

Figure 182. Reset Overlap and Branch

Read Tape in Overlap Mode

Instruction Format.

Mnemonic	Op Code	A-address	B-address	d-character
SPS MU	<u>M</u>	@Ux	xxx	R

Function. The tape unit specified in the A-address is started. The d-character specifies a tape-read operation. The @ in the hundreds position of the A-address indicates that this operation is to be performed in the overlap mode.

The B-address specifies the high-order position of the tape read-in area of storage. The machine reads magnetic tape until either an inter-record gap in the tape record or a group-mark with a word-mark in core storage is sensed. The inter-record gap indicates the end of the tape record, and a group-mark (code CBA 8421) is inserted in 1401 core storage at this point.

Word Marks. Word marks are not affected.

Timing. $T = .0115 (L_I + 1)$ ms + T_M . (See section on *Tape Timing*.)

Note. When reading high-density tape from an IBM 729 II, IV, or V, part of start time of the tape unit can

be overlapped (minimum overlapped times are 6.6 ms in 729 II; 4.4 ms in 729 IV; or 6.6 ms in 729 V. Reading low-density tape from a 729 II, IV, or V, or a 7330 in either high- or low-density permits overlapping of start time and processing time. That is, processing cycles are taken between characters read from magnetic tape.

Address Registers After Operation.

I-Add. Reg.	O-Add. Reg.
NSI	Group mark + 1

Example. Read the record from the tape unit labeled 2 to the 1401 core-storage area labeled OUTPAR (0419). The tape-record characters are moved into core storage until the transfer is stopped by an inter-record gap in the tape record, or a group-mark with a word-mark is sensed in 1401 core storage (Figure 183).

LINE		COUNT	LABEL	OPERATION	(A) OPERAND				(B) OPERAND				d									
3	2	1	13	14	15	16	17	18	19	20	21	22	23	24	25	26	27	28	29	30	31	32
0	1	0		MU	2																	
@U2 OUTPAR																						

For autocoder coding see the IBM 1401 Autocoder Bulletin (J24-1434).

Assembled Instruction: M @U2 419 R

Figure 183. Read Tape in Overlap Mode

Write Tape in Overlap Mode

Instruction Format.

Mnemonic	Op Code	A-address	B-address	d-character
SPS MU	<u>M</u>	@Ux	xxx	W

Function. The tape unit designated in the A-address is started. The d-character specifies a tape-write operation. The data from core storage is written on the tape record. The @ in the hundreds position of the A-address indicates that this operation is to be performed in the overlap mode.

The B-address specifies the high-order position of the record in storage. A group-mark with a word-mark in 1401 core storage stops the operation. The group-mark with a word-mark causes an inter-record gap.

Word Marks. Word marks are not affected.

Timing. $T = .0115 (L_I + 1)$ ms + T_M . (See section on *Tape Timing*.)

Note. When writing high-density tape on an IBM 729 II, IV, or V, only start time of the tape unit can be overlapped (minimum overlapped times are 7.3 ms in 729 II; 4.9 ms in 729 IV; or 7.3 ms in 729 V).

Writing low-density tape on a 729 II, IV, or V, or a 7330 in either high- or low-density permits overlapping of start time and processing time. That is, processing cycles are taken in the time between the writing of characters on magnetic tape.

Address Registers After Operation.

I-Add. Reg. O-Add. Reg.
 NSI Group mark + 1

Example. Transfer the contents of the core-storage area labeled TPOUT (0525) to the tape unit labeled 3. The transfer of data is stopped by a group-mark with a word-mark in core storage (Figure 184).

LINE	COUNT	LABEL	OPERATION	(A) OPERAND				(B) OPERAND				d			
				ADDRESS	±	CHAR. ADJ.	IND.	ADDRESS	±	CHAR. ADJ.	IND.				
3	8	7	8	13	14	16	17	23	24	27	28	34	35	38	39
0	1	0													
				M	@	U	3					W			

For autocoder coding see the IBM 1401 Autocoder Bulletin (J24-1434).

Assembled Instruction: M @U3 525 W

Figure 184. Write Tape in Overlap Mode

Read a Card in Overlap Mode

Instruction Format.

Mnemonic Op Code
 R 1

Function. This code, if overlap is ON, causes a card to feed, and causes all 80 columns of information to be read into core-storage locations 001 through 080 while processing continues.

Word Marks. Word marks are undisturbed.

Timing. $T = .0115 (L_1 + 1) \text{ ms} + I/O$.

Note: Processing is interrupted each time a row in the card is scanned (9-row, 8-row, etc.). The bits in a column are developed in the A-register, and the O-address register keeps track of which column is being scanned. While the scanning operation is being performed, the data required for processing is temporarily stored in the O-register. When the row scan is completed, the data in the O-register is sent back to the A-register and processing continues.

The read-in area of core storage *must not* be addressed while an overlap operation is being performed.

Address Registers After Operation.

I-Add. Reg. O-Add. Reg.
 NSI 081

Example. Read a card in overlap mode (Figure 185).

SPS

LINE	COUNT	LABEL	OPERATION	(A) OPERAND				(B) OPERAND				d			
				ADDRESS	±	CHAR. ADJ.	IND.	ADDRESS	±	CHAR. ADJ.	IND.				
3	8	7	8	13	14	16	17	23	24	27	28	34	35	38	39
0	1	0													
				R											

Autocoder

Label	Operation	OPERAND								
6	15	18	20	21	25	30	35	40	45	80

Assembled Instruction: 1

Figure 185. Read Card in Overlap Mode

Read in Overlap Mode and Branch

Instruction Format.

Mnemonic Op Code I-address
 R 1 xxx

Function. This is the same as the READ A CARD instruction, except that the next instruction is taken from the I-address instead of from the next, sequential instruction address. The program branch occurs when the instruction is processed; that is, before card reading is completed.

Word Marks. Word marks are not affected.

Timing. $T = .0115 (L_1 + 1) \text{ ms} + I/O$.

Address Registers After Operation.

I-Add. Reg. O-Add. Reg.
 NSI 081

Example. Read a card in the overlap mode, and branch to the location labeled OVERCD (1500), Figure 186.

SPS

LINE	COUNT	LABEL	OPERATION	(A) OPERAND				(B) OPERAND				d			
				ADDRESS	±	CHAR. ADJ.	IND.	ADDRESS	±	CHAR. ADJ.	IND.				
3	8	7	8	13	14	16	17	23	24	27	28	34	35	38	39
0	1	0													
				R											

Autocoder

Label	Operation	OPERAND								
6	15	18	20	21	25	30	35	40	45	80

Assembled Instruction: 1 V00

Figure 186. Read and Branch in Overlap Mode

Punch a Card in Overlap Mode

Instruction Format.

Mnemonic Op Code
 P 4

Function. This code, if overlap mode is ON, causes the data in storage locations 101 through 180 to be punched into an IBM card while processing continues.

Word Marks. Word marks are not affected.

Timing. $T = .0115 (L_I + 1) \text{ ms} + \text{I/O}$.

Note. Processing is interrupted each time a row in the card (12-row, 11-row, etc.) is scanned for punching. The data to be punched is developed in the B-register, and the O-address register keeps track of which column is being punched. While the punch-scan operation is being performed, the data required for processing (from the A-register) is temporarily stored in the O-register. When the row punch-scan is completed, the data in the O-register is sent back to the A-register and processing continues.

The punch-out area of core storage *must not* be addressed while an overlap operation is being performed.

Address Registers After Operation.

I-Add. Reg. O-Add. Reg.
 NSI 181

Example. Feed a card, and punch in overlap mode (Figure 187).

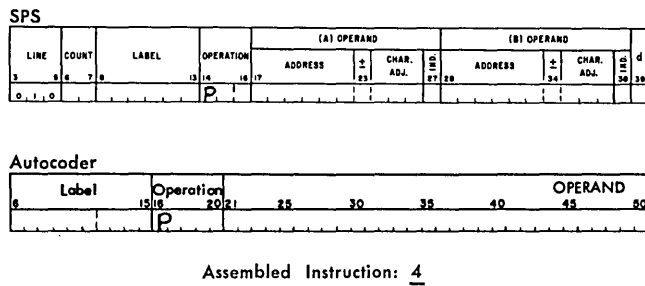

Figure 187. Punch in Overlap Mode

Punch and Branch in Overlap Mode

Instruction Format.

Mnemonic Op Code I-address
 P 4 xxx

Function. This is the same as the PUNCH A CARD instruction, except that the next instruction is taken from the I-address instead of from the next, sequential instruction address. The branch occurs when the instruction is processed; that is, before punching has been completed.

Word Marks. Word marks are not affected.

Timing. $T = .0115 (L_I + 1) \text{ ms} + \text{I/O}$.

Address Registers After Operation.

I-Add. Reg. O-Add. Reg.
 NSI 181

Example. Punch a card in overlap mode, and branch to the location labeled OVSTAT (1758), Figure 188.

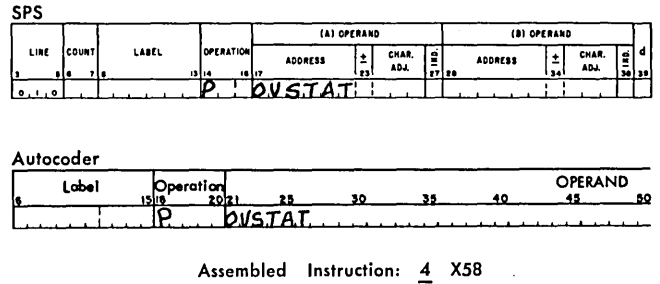

Figure 188. Punch and Branch in Overlap Mode

Branch if Indicator On

Instruction Format.

Mnemonic Op Code I-address d-character
 SPS B B xxx x
 A BIN

Function. The d-character specifies the indicator tested. If the indicator is ON, the next instruction is taken from the I-address. If the indicator is OFF, the next sequential instruction is taken. Figure 189 shows the symbols that are valid d-characters and the indicators they test.

Indicators. Reader Busy. This indicator turns ON when the IBM 1401 is performing an overlapped read operation. The indicator automatically turns OFF when the overlapped read operation is completed.

Punch Busy. This indicator turns ON when the 1401 is performing an overlapped punch operation. The indicator automatically turns OFF when the overlapped punch operation is completed.

Tape or Input-Output Busy. This indicator turns ON when the 1401 is performing an overlapped magnetic tape or input-output (1419, or 1011) operation. The indicator automatically turns OFF when the overlapped operation is completed. Note: Without the advanced programming special feature, the B-address register is reset when the next sequential instruction is taken. If the system has the advanced programming special feature, the B-address register

d-CHARACTER	INDICATORS
H	Reader Busy
I	Punch Busy
J	Tape or Input-Output Busy

Figure 189. Processing Overlap Indicators

Page 104 — First paragraph in second column beginning with line 8, insert:

branch back to the test punch busy operation. If the reader was busy, go to the main program (which eventually goes to the test punch busy operation).

B (xxx) L BRANCH ON TAPE TRANSMISSION ERROR. If the tape adapter unit is busy when this instruction is given, the 1401 interlocks until the TAU is not busy, before making the test for a tape transmission error.

B (xxx) H BRANCH ON READER BUSY. If the reader is busy when this instruction is given, and the interlock-stop condition is ON in the 1402, the 1401 stops. The stop occurs for these conditions:

- a. a card jam in the 1402 read or punch feed
- b. a full stacker
- c. an empty hopper
- d. the I/O check-stop switch on the 1401 console is ON, and one of the following conditions occur:

Hole-count check
Validity check
Punch check

B (xxx) I BRANCH ON PUNCH BUSY. If the punch is busy when this instruction is given, and the interlock-stop condition is ON in the 1402, the 1401 stops. The stop occurs for these conditions:

- a. a card jam in the 1402 read or punch feed
- b. a full stacker
- c. an empty hopper
- d. the I/O check stop switch on the 1401 console is ON, and one of the following conditions occurs:

Hole-count check
Validity check
Punch check

2. When operating in the overlap mode, the following conditions cause a processing unit stop:
 - a. When a storage-address error occurs, processing stops.

- b. If a process error occurs during an overlapped I/O cycle, processing stops immediately; however, the input-output operation continues.

- c. If a process error occurs between overlapped I/O cycles, processing stops immediately, and the input-output operation continues.

3. Read and punch-release operation codes (8 and 9) are not operative in the overlap mode. However, the read or punch (1 and 4) operation codes, when used in the overlap mode, perform the same function. If a tape operation overextends the time allotted it (data to or from tape is still being processed when data from a card is available), a tape transmission error occurs and the data from tape does not enter/leave core storage. Normal tape-error procedure can correct this type of error. If a tape operation is given after a read or punch (1 or 4) operation, the tape operation and processing are interlocked until the read or punch operation is completed.

Space Suppression Feature

This feature enables the system to suppress the automatic space taken by the printer after a line has been printed. The d-character S is used with any printer instruction (operation codes 2, 3, 6, or 7) to prevent the IBM 1403 from spacing after a print operation. Therefore, the next line printed appears on the same line as a line printed by using a SPACE SUPPRESSION instruction (2S).

Address Modification

It becomes necessary in some 1401 programs to perform the same operations repetitively, with a change only in the A- or B-address. The changing of an address while retaining the rest of the instruction is called *address modification*. Address modification can result in savings in the number of program steps and in the number of storage requirements. In some cases, the program itself determines if and how addresses are to be changed in order to perform the correct program steps for conditions that arise during the processing of data.

There are two basic methods of address modification. The first method does not require the indexing feature. The second method makes use of the indexing feature, which is a special feature for the 1401 system.

Address Modification Without Indexing Feature

Address modification uses the A- and B-bit accumulation that can occur in the hundreds and units positions of a field. This accumulation has already been noted in connection with overflow indication in the *Arithmetic Operations* section of the manual.

Using Modulus 4 Arithmetic

For systems of 4,000 storage positions or less, A- and B-bit accumulation should occur only in the hundreds position, and is based on modulus 4 arithmetic. To understand how a modulus 4 arithmetic operation is accomplished, let us assign digital values to the A- and B-bit configurations:

No A, No B = 0
 A = 1
 B = 2
 AB = 3

In a modulus 4 system, the highest digit is 3. Values in excess of three are equal to that value minus four.

A + A	= B	or	1 + 1 = 2
A + B	= AB	or	1 + 2 = 3
B + B	= NoANoB	or	2 + 2 = 0
A + AB	= NoANoB	or	1 + 3 = 0
A + NoANoB	= A	or	1 + 0 = 1
B + AB	= A	or	2 + 3 = 1
B + NoANoB	= B	or	2 + 0 = 2
AB + AB	= B	or	3 + 3 = 2

Figure 191. A-Bit and B-Bit Values

For example, 5 is a digit 1. In this system, only two factors can be accumulated at a time (Figure 191).

Digit values in the high-order position of a field accumulate in the normal manner. In systems of 4,000 core-storage positions or less, it is assumed that there is a word mark in the high-order position of the address being modified.

Modification to a higher address in 000-999 address range is:

Increase address 472 by 345.

$$472 + 345 = 817$$

Modification to an address greater than 1000 is:

Increase address 912 by 314.

$$912 + 314 = 1226 \text{ or } S26$$

S = A2 (overflow in high-order position sets an A-bit using modulus 4 arithmetic and turns on the arithmetic overflow indicator).

Increase address 1754 (X54) by 1204 (S04).

$$X54 + S04 = R58$$

$$X = (A7)$$

$$S = (A2)$$

Using the rules of modulus 4 arithmetic, A + A = B-bit, the new address is:

958 with a B-bit over the high-order position

(B9 = R) or R58 (2958).

To decrease an address, a different means must be used. Modulus 4 arithmetic operates for addition only. Decreasing an address requires the addition of a complement, rather than doing a conventional subtract operation.

In systems of 4,000 core storage positions or less, the

16,000's complement of the decrement is added to the address to be modified.

Decrease address 879 by 148.

$$\begin{aligned}
 16000 - 148 &= 15,852 \text{ (H5B) = complement} \\
 879 + \text{H5B} &= 731 \text{ (with arithmetic overflow)} \\
 \text{H} &= \text{BA8} \\
 \text{B} &= \text{BA2}
 \end{aligned}$$

Using the modulus 16 rules, the arithmetic overflow adds an A-bit in the hundreds position (the hundreds position already contains A- and B-bits, and the units position contains A- and B-bits the combination of which indicates a 15,000 to 15,999 block address). The addition of the A-bit increases the value of the zone bits to 16, which, according to modulus 16 rules has a new address value of 0 (000-999 block address). Therefore, the new address is 731, and the overflow indicator is ON.

Using the Modify Address Instruction

For systems with more than 4,000 positions of core-storage (with the IBM 1406 Storage Unit), A- and B-bit accumulation occurs in both the hundreds and units position. In these systems, the MODIFY ADDRESS instruction must be used. This instruction makes use of modulus 16 arithmetic to perform its operations.

In a modulus 16 system, the highest digit is 15. Values in excess of fifteen are equal to that value minus sixteen. For example, 16 is a digit 0, 17 is a digit 1, etc. In this system, only two factors can be accumulated at a time (Figure 192).

Digit values in high- and low-order positions of a field accumulate in the normal manner.

The MODIFY ADDRESS instruction is standard in systems with more than 4,000 core-storage positions, and does not require word marks in the high-order positions of the addresses.

			Hundreds	Units
A + A	= B	or	2	8
A + B	= AB	or	3	12
B + B	= No A No B	or	0	0
A + AB	= No A No B	or	0	0
A + No A No B	= A	or	1	4
B + AB	= A	or	1	4
B + No A No B	= B	or	2	8
AB + AB	= B	or	2	8

Figure 192. Modulus 16 Arithmetic

Increase address 7355 (C5V) by 1800 (Y00).

$$\begin{aligned}
 \text{C5V} + \text{Y00} &= /5\text{N} \text{ (with arithmetic overflow)} \\
 \text{C} &= (\text{AB3}) \\
 \text{V} &= (\text{A5}) \\
 / &= (\text{A1}) \\
 \text{Y} &= (\text{A8}) \\
 \text{N} &= (\text{B5})
 \end{aligned}$$

Because there are more than 4,000 core storage positions, the MODIFY ADDRESS instruction must be used. Using the rules of modulus 16 arithmetic, the addition of the existing zone bits results in a No A, No B (0 zone value) in the hundreds position, and an A (zone value 4) in the units position. The addition of the AB and A-bits (= 0) in the hundreds position results in a zone carry-back (A-bit) to the units position. This A-bit added to the A-bit already there results in a B-bit (zone value 8) in the units position. The arithmetic digit carry adds a new A-bit in the hundreds position. The result is address /5N (9155).

To decrease an address, only modulus 16 arithmetic is used. Because modulus 16 arithmetic operates for addition only, decreasing an address requires adding a complement, rather than doing a conventional subtract operation. The 16,000's complement of the decrement is added to the address to be modified. If the result is an address outside the storage limit of the system, an invalid address condition is indicated.

Decrease 1829 (Y29) by 161.

$$\begin{aligned}
 16,000 - 161 &= 15,839 \text{ (H3I) complement} \\
 \text{Y29} + \text{H3I} &= \text{W68} \text{ (with arithmetic overflow)} \\
 \text{Y} &= \text{A8} \\
 \text{H} &= \text{AB8} \\
 \text{I} &= \text{AB9}
 \end{aligned}$$

Using the modulus 16 rules and the MODIFY ADDRESS instruction, the addition of the existing zone bits results in zero (hundreds position, A + AB = 4; units position, AB = 12; 4 + 12 = 16, which has an address value of 0). Then the arithmetic overflow adds a new A-bit in the hundreds position. The result is address W68 (1668).

Address Modification with Indexing Feature

Three index locations are provided in the IBM 1401 Processing Unit to modify addresses automatically. This means that fewer instructions are needed to accomplish the modification of addresses. For a description of the indexing feature refer to the *Special Features* section of this manual.

The 1401, equipped with the indexing feature has three index locations.

Index Location	Storage Locations
1	087-089
2	092-094
3	097-099

The programmer selects those instructions to be indexed, by designating the index location using the tens positions of the instruction address. This designation is referred to as *tagging*.

OP	Positions Tagged	
	AAA	BBB
Zone bits designate the index location involved.		
Index Location	Tens Position	Zone Punch
1	A-bit	zero
2	B-bit	eleven
3	A- and B-bits	twelve

When a program is written using the symbolic programming system, indexing is indicated by writing a 1, 2, and 3 in the index column of the symbolic coding sheet (cc 27 for (A) operand—cc 38 for (B) operand).

Digit	Result
1	Index operand by contents of 087-089
2	Index operand by contents of 092-094
3	Index operand by contents of 097-099

The (A) and (B) operands can be symbolic or actual addresses. In the processing of instructions:

1. The A-address and B-address are analyzed for indexing as they are moved into the address registers.
2. The contents of the proper index location (indexing factor) is added to the contents of the address register and develops the effective address there, when indexing is indicated.
3. Three or four additional cycles are required for each address indexed.

		INSTRUCTION IN STORAGE	INDEX LOCATION			EFFECTIVE INSTRUCTION
			1	2	3	
1. INDEX THE B-ADDRESS	BEFORE	<u>M</u> 080 1A7	010	025	050	
	AFTER	<u>M</u> 080 1A7	010	025	050	<u>M</u> 080 167
2. INDEX A- AND B-ADDRESS	BEFORE	<u>M</u> 0S0 1J7	010	025	050	
	AFTER	<u>M</u> 0S0 1J7	010	025	050	<u>M</u> 030 142
3. INDEX A- AND B-ADDRESS	BEFORE	<u>M</u> J80 8C0	010	025	050	
	AFTER	<u>M</u> J80 8C0	010	025	050	<u>M</u> J70 880

Figure 193. Indexing

Increasing an Address

To increase a core storage address using the indexing feature, the contents of the index location is added to the selected address register. Figure 193 illustrates various methods of address modification using the index locations.

Decreasing an Address

To decrease an address, the 16000's complement of the amount to be subtracted from the address *must* be stored in the index location.

Example: Decreasing
Required Decrease a B-address by 10
Indexing factor = 16000 - 10 (15990)
(Complement)

The 15990 converts to the three digit factor I9? (Figure 194).

	INSTRUCTION IN STORAGE	INDEX LOCATION			EFFECTIVE INSTRUCTION
		1	2	3	
BEFORE	<u>L</u> 123 9T7	I9?			
AFTER	<u>L</u> 123 9T7	I9?			<u>L</u> 123 927

$$937 + 19? = 927 \text{ (with overflow)}$$

$$1 = (AB9)$$

$$? = (AB0)$$

Figure 194. Converting Address

Using the modulus 16 rules, the arithmetic overflow adds an A-bit in the hundreds position (both the hundreds and tens positions already contain A- and B-bits, the combination of which indicates a 15,000-15,999 block address). The addition of the A-bit increases the value of the zone bits to 16, which, according to modulus 16, has an address value of 0 (000-999 block address). Therefore, the new address is 927. With the indexing feature, even though there was an overflow, the arithmetic overflow indicator is *not* turned on.

Note: Refer to *Address Validity* in the *Increase Core Storage* section of *Special Features*.

IBM 1401 Console Keys, Lights, and Switches

The IBM 1401 console has the operating keys, lights, and switches for the processing unit and connecting equipment. The console display has a data-flow schematic to assist the operator in tracing the path of data through the IBM 1401 Processing Unit (Figure 195).

Display lights are provided to indicate the bit-configuration of the data in the system registers.

The console keys are illuminated; when lit, they indicate that the particular function is on or is operative. During a manual operation, when a key is pressed, it lights, indicating that the function is controlled by the key.

Displaying Information

The 1401 console employs a back-lighting concept to display data. The bit configuration of each character in each of the machine's logical elements is shown in binary-coded decimal form (including check-bit and word-mark status). The data is displayed, one character at a time. Also, an error at any display location is indicated by a red light that glows in the legend directly above the character display.

PROCESS LIGHT

This light comes ON when an error occurs in the processing unit. The light and the error indication are reset by pressing the check-reset key. Machine operation is resumed by pressing the start key.

RAMAC LIGHT

This light comes ON when an error condition exists in the IBM 1405 Disk Storage Unit. One of the indicator lights on the 1405 specifies the particular condition that caused the RAMAC light to come ON.

TAPE LIGHT

This light comes ON if a tape error occurs during a read or write operation. It also comes ON if the tape-select switch is in other than the N or D position. It is turned OFF automatically when the error indicator is reset by a subsequent tape operation.

EXT I/O LIGHT (EXTERNAL INPUT-OUTPUT LIGHT)

This light come ON when one of the external input and/or output devices of the 1401 system requires

operator attention. These devices are:

- The IBM 1009 Data Transmission Unit
- The IBM 1011 Paper Tape Reader
- The IBM 1412 Magnetic Character Reader
- The IBM 1418 Optical Character Reader
- The IBM 1419 Magnetic Character Reader

READER LIGHT

This light comes ON when the card reader requires operator attention (empty hopper, full stacker, card jam, clutch failure, hole-count check-error, or validity error). See *Restart Procedure* for corrective action.

PUNCH LIGHT

This light comes ON when the card punch requires operator attention (empty hopper, full stacker, full chip box, clutch failure, or hole-count check-error). See *Restart Procedure* for corrective action.

OVERLAP LIGHT

This light comes on when any process error occurs during an overlap cycle. Ordinarily, the process light will also be lit along with an indication of the type of failure. However, if an A-register check occurs during a tape-overlap cycle, only the overlap light turns ON. This light is reset by pressing the check-reset key. Press the start key to restart the machine.

PRINTER LIGHT

This light comes ON when an error occurs in the printer. See *Restart Procedure* for corrective action.

STORAGE LIGHT

This light comes ON when a parity check occurs on a character as it is read into storage. This light is reset by pressing the check-reset key. Press the start key to restart the machine.

B LIGHT

This light comes ON when a B-register parity check occurs. The lights below the B-register light indicate the coded character, check-bit status and word-mark status of the B-register. This light is reset by pressing the check-reset key. Press the start key to restart the machine.

A LIGHT

This light comes ON when an A-register parity check occurs. The lights below the A-register light indicate

the coded character, check-bit status and the word-mark status of the A-register. This light is reset by pressing the check-reset key. Pressing the start key restarts the machine.

LOGIC LIGHT

This light comes ON when an error occurs in an arithmetic operation. It is reset by pressing the check-reset key, and the machine is restarted by pressing the start key.

Logic Block Lights

O-FLOW LIGHT

This light comes ON when an overflow condition exists in the machine. The light remains on until the overflow indicator turns OFF by a programmed test, or by pressing START RESET.

B ≠ A LIGHT

This light comes ON when an unequal condition exists during a COMPARE instruction.

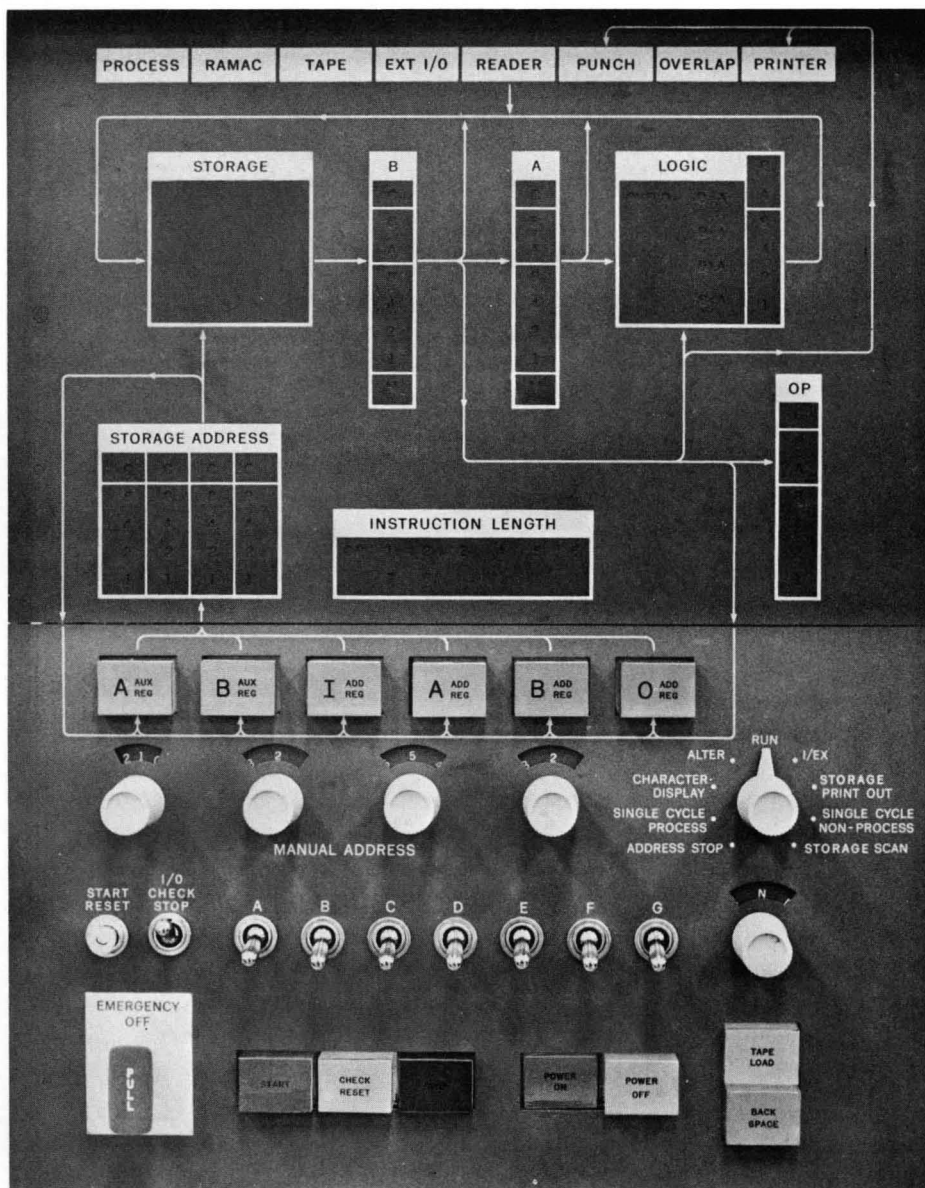

Figure 195. IBM 1401 Console

B = A LIGHT

This light comes ON when an equal condition exists during a COMPARE instruction with the high, low, equal compare special feature.

B > A LIGHT

This light comes ON if the value of the B-field is greater than the value of the A-field, or if the A-field is shorter than the B-field. This works with the high, low, equal compare special feature.

B < A LIGHT

This light also works in conjunction with the high, low, equal compare special feature and comes ON when the value of the B-field is less than the value of the A-field in a COMPARE instruction.

BIT DISPLAY LIGHTS

These lights show the bit configuration (at the end of the B-cycle) of the sum of the characters being processed in an arithmetic operation.

Register Lights

OP-REGISTER LIGHT

The OP light comes ON when an incorrect operation code exists in the Op-register. The lights below indicate the coded character and check-bit status of the character in the Op-register.

INSTRUCTION LENGTH LIGHTS

These lights indicate which character of the instruction is being read out during instruction cycles.

STORAGE-ADDRESS LIGHT

This light comes ON when an addressing check occurs. The lights below it, displaying the address, can be checked for a parity-error condition.

Register Key-Lights

I-ADDRESS REGISTER KEY-LIGHT

This is a lighted key that turns the light ON, and displays the contents of the I-address register in the storage address display lights. If the machine is stopped during the I- (instruction) cycle, the I-address register light is ON and the storage address display lights indicate the last I-address that addressed storage.

A-ADDRESS REGISTER KEY-LIGHT

This is the same as the I-address register key-light except that it refers to the A-address register and the A-cycle of the processing operation.

B-ADDRESS REGISTER KEY-LIGHT

This is the same as the I-address register key-light except that it refers to the B-address register and the B-cycle of the processing operation.

A- AND B-AUXILIARY REGISTER KEY-LIGHTS

Pressing either the A- or the B-auxiliary register key-light displays the contents of the corresponding register. The auxiliary registers are part of the multiply-divide special feature.

O-ADDRESS REGISTER KEY-LIGHT

This is a lighted key that turns the light ON, and displays the contents of the O-address register in the storage-address display lights. If the machine is stopped during an overlap cycle, the O-address register light is ON and the storage-address display lights indicate the last overlap address that addressed storage.

Pressing the O-address register key does not turn off any other key lights, but pressing any other address-register key turns the O-address register light OFF. The O-address register key-light and any other address register key-light can be ON at the same time.

Storage Address Dial Switches

The four dial switches labeled *Manual Address* select the address to be entered in the storage-address register. These switches are effective only with these selected positions of the *mode switch*:

1. Character Display
2. Alter
3. Address Stop
4. Storage Print Out
5. Storage Scan

To set the contents of the A-address register to 1200:

1. Set the mode switch to ALTER
2. Set the manual address switches to 1200.
3. Press the A-address register key-light.
4. Press the start key.

The storage-address display lights then show the bit configurations for this address (1200).

The manual-address switches also select a storage location for a display or alteration, without disturbing the contents of the address registers.

SENSE SWITCHES

Seven sense switches can be included in the IBM 1401 Processing Unit. The manual toggle switches that control them are located on the console. Switch A controls last-card operations by making the BRANCH IF INDICATOR ON (d-character A) instruction a branch, only when the last card in the reader has passed the read station. Switch A is standard in all systems except Model D. Six additional sense switches (B, C, D, E, F, and G) are special features, except on Model C, which has all the sense switches as a standard feature.

The B xxx d instruction can interrogate the setting of the switch specified by the d-character, at any time during processing, and cause a branch to the I-address if the switch is ON.

Mode Switch

The mode switch selects the nine modes of machine operation:

RUN

When the mode switch is set to RUN, the system is under control of the stored program.

I/EX (INSTRUCTION EXECUTION)

When the mode switch is set to I/EX, the first time the start key is pressed, the machine reads one complete instruction from storage and then stops. This is called the *instruction phase*.

The next time the start key is pressed, the machine executes the instruction. This is called the *execution phase*.

Subsequent pressing of the start key results in alternate instruction and execution phases.

When performing a 1407 operation, the 1401 does not stop between the instruction and execution phases.

SINGLE CYCLE PROCESS

In this mode, each pressing of the start key causes the machine to take one .0115-millisecond storage cycle and advance through the instruction and execution cycles of the program one character at a time. When the machine is single-cycled through an instruction, the following actions take place: At I Op time (first character time of an instruction (I) cycle), the I-address register key-light comes ON to indicate that the I-address register is addressing storage. The storage-address display indicates the instruction address. The character at that address is read from storage to the

B-register and displayed. Because the first I-cycle reads out the operation code of the instruction, the contents of the B-register is also read into the Op-register and displayed. The first light of the instruction length display comes ON, displaying the legend OP.

The next pressing of the start key causes the storage address to increase by one and the next character of the instruction to enter the B-register. If this character does not have a word mark appearing with it in the B-register, it also enters the A-register. The instruction length is increased by 1, lighting the 1 on the display light. During this cycle, the character from the B-register enters the thousands and hundreds position of the A-address register and/or the B-address register except during MOVE, LOAD, or STORE B-ADDRESS REGISTER instruction when the character enters *only* the A-address register. During a STORE A-ADDRESS REGISTER instruction, this is a dummy I-Op, and the Op-light (instruction-length block) remains on. Pressing the key a third time during a store A-address register operation advances the I-instruction length to I-1, and the character in the B-register functions as previously stated, except it only enters the A-address register.

Each successive operation of the start key causes the storage address to increase by 1 and the instruction length to advance by 1.

The operations that occur for each of the eight instruction-length display cycles are:

<i>Cycle</i>	<i>Operation</i>
1	The operation code enters the Op-register and the B-register. Because this is the first I-cycle, the A-register is undisturbed.
2	During the second cycle, the second instruction character (first character of the A-address) enters the hundreds position of the A- and B-address registers and the A-register by way of the B-register.
3	The third character of the instruction enters the tens position of the A- and B-address registers and the A-register through the B-register.
4	The fourth instruction character enters the units position of the A- and B-address registers, and the A-register through B-register.
5	The fifth instruction character (first character of the B-address) enters the hundreds position of the B-address register, and the A-register through the B-register.
6	The sixth instruction character goes to the tens position of the B-address register, and the A-register through the B-register.

- 7 The seventh character of the instruction (last character of the B-address) enters the B-address register, and the A-register through the B-register.
- 8 The first character of the next instruction enters the B-register only. Because this is the last I-cycle for this instruction, the A-register and the Op-register, the A- and B-address registers are undisturbed. The detection of a word mark associated with this character signals the machine that this is the Op code for the next instruction. The instruction phase of this operation stops, and the instruction that was just addressed is ready to be executed. Note that the I-address register contains the address of the high-order position of the next sequential instruction. If the character is a d-modifier, it enters the A-register by way of the B-register.
- 9 If the previous character was a d-modifier followed by the first character of the next instruction, the characters enter the B-register only. The same conditions occur as explained in cycle 8.

On all I-cycles in which no word mark is detected in the B-register, the data from this register transfers to both the A-register and the appropriate positions of the A- and B-address registers. Detection of a word mark in the B-register, after the first I-cycle, indicates the operation code of the next successive instruction. When this condition is sensed, the instruction phase is completed and the execute cycle is set up. One of the instruction length lights is ON at this time to indicate the number of characters read.

The next operation of the start key causes the machine to take the first execution cycle. Each successive pressing of the start key causes an additional single execution cycle to occur until the operation has been completed. On I/O operations, except read release and punch release, all of the execute cycles are executed immediately.

Repeated operation of the start key advances the program through successive instruction and execution cycles.

SINGLE-CYCLE NON-PROCESS

This is similar to the single-cycle process mode, except that no data enters storage from the A-register or from the logic unit. Data always enters storage from the

B-register only. This mode allows the operator to observe the results of arithmetic operations, one character at a time, in the logic display, without destroying the original B-field data.

CHARACTER DISPLAY

When the machine is operating in this mode, the start key is pressed, displaying in the B-register the character at the address selected by the manual-address switches.

STORAGE PRINT OUT

This mode of operation permits any 100-character block of storage to be printed. The hundreds and thousands manual address switches select the desired block of storage.

Example: 12xx is set in the manual-address switches and the start key is pressed. The 100 characters in the selected block (1201-1300) print automatically in print positions 1-100. Another automatic print cycle indicates the word marks for that block by printing 1's in their corresponding print positions on the second line. This is used to great advantage in program testing, because the contents of a block in core storage are printed and can be easily examined by the programmer. Thus, this feature increases both processing and programming efficiency. A specific storage position can be located by using the IBM Diagramming Template (Form X24-5884) which has a ten-to-the-inch printing scale.

ALTER

The operator can manually change the contents of any address register or storage location, if the mode switch is set to ALTER. To change the contents of address registers:

1. set the manual address switches at the desired location
2. press the appropriate address register key-light
3. press the start key
4. the selected address register contains the new address, and is displayed in the storage-address register.

To change the contents of a storage location:

1. set the manual address switches to the desired location
2. select the bit configuration of the character to be

entered by setting the eight bit-switches located on the auxiliary console

3. turn on the enter switch (also on the auxiliary console).

STORAGE SCAN

When the mode switch is set to STORAGE SCAN, holding down the start key causes the 1401 to start reading out of storage beginning at the address set in the manual-address switches and continues to the end of core storage. If an invalid character is detected in storage, the machine stops, and the check light associated with the error is turned ON. The storage position in error is shown in the storage address display unit. The B-register displays the contents of the storage position in which the error was detected. This character can be corrected by using the bit-switches, manual-address switches, and the enter key (see *Alter mode*).

After the error condition is corrected, the mode switch is again set to STORAGE SCAN, and the start key is held down to cause another read-out from storage. This procedure insures that all positions of storage are correct.

If there is a print, read, or punch check, scanning stops at the storage position in error. Pressing the start key a second time allows the scan to continue.

ADDRESS STOP

When the mode switch is set to ADDRESS STOP, pressing the start key starts the program. The machine automatically stops when the machine encounters the address selected by the manual address switches. This feature is commonly used in program testing operations, because the machine can be stopped at the address of an instruction anywhere in the program, except for input or output operations.

Control Keys and Switches

START KEY

This key is used to initiate or resume machine operation after a manual, programmed, or automatic stop. Similar keys are found on each of the other units in the system. The setting of the mode switch conditions the operation of the start key:

1. During a normal run mode, or address stop mode, the system can be started by pressing the start key on any of the units.
2. To restart, following a process error indication, the check-reset key on the console or on the I/O unit

must be pressed to reset the unit before the start key is pressed.

3. Following a card jam or misfeed in either the reader or punch, or a hole count or validity error, the cards in the associated feed must be run out by means of the non-process run-out key for that feed, and its hopper must be reloaded before the I/O check-reset and start keys are pressed.

START RESET KEY

This key resets the system (except for the data in the address registers and core storage) so that the operator can restart the operation. It turns OFF all indicators that were turned ON by the previous program.

STOP KEY

This key stops processing in the system. It is not effective until the instruction being executed is completed. Similar stop keys (without lights) are provided on the 1402 and 1403. It is lighted only if a programmed stop is encountered.

CHECK RESET KEY

An error detected by the checking circuits, lights this key. It must be pressed following a processing error. The system can then be restarted by pressing the start key.

TAPE SELECT SWITCH.

This rotary switch is set to the normal position (N) during automatic operation. The switch can be set to the numbers (1-6) that correspond to any of the attached tape units, when manual operation is desired.

The D (diagnostic) setting of the switch allows characters from tape to be read into 1401 core storage just as they appear on the tape (or disk) record. If an invalid character is transferred into storage, storage can be scanned, allowing the operator to display the character and make the necessary corrections. Improper system operation results if the 1401 is operating in the overlap mode with the tape-select switch in the D-position.

BACKSPACE KEY

This key works in conjunction with the tape-select switch. When the switch is set to a specific tape unit, pressing this key causes the tape in the selected unit to backspace over one record each time the key is pressed.

TAPE LOAD KEY

When this key is pressed, tape unit 1 is automatically selected and tape data starts loading at address 001 and continues until an inter-record gap is sensed.

I/O CHECK STOP SWITCH

When this switch is in the ON position (up), the machine stops at the completion of an I/O operation, if an error occurs during that operation. In the OFF position (down), the machine does not stop, if it detects a hole-count check in the card reader or card punch, a validity check error in the card reader, or a print check error. With the switch in the OFF position, error detection must be accomplished by programming.

POWER ON SWITCH

This switch controls the main power supply for the entire system.

POWER OFF SWITCH

This switch turns off the main power supply.

EMERGENCY OFF SWITCH

This is a pull switch, located on the console. In an emergency, pulling this switch disconnects all the power from the entire system. This switch must be manually reset by a customer engineer before power is restored to the system.

Auxiliary Console

The auxiliary console panel is located below the main console of the IBM 1401 Processing Unit (Figure 196). Its purpose is to provide additional operator control of the system.

Auxiliary Console Switches

BIT SWITCHES

Eight bit-switches alter characters in storage. These switches are used in conjunction with the alter mode as explained in the mode switch description.

The dash over the digit indicates the OFF position.

ENTER SWITCH

This switch enters the characters selected by the bit switches into storage, when the mode switch is set to ALTER.

CHECK STOP SWITCH

This is normally ON, to stop the machine automatically when a process check occurs. If the switch is in the OFF position, the machine does not stop on error conditions, except for Op-register and address register checks, and input-output checks.

I/O CHECK RESET SWITCH

This switch resets error conditions sensed in an I/O unit. It is used primarily by customer engineering.

AUXILIARY MODE SWITCH

This switch is a three-position dial switch used with the IBM 1406 Storage Unit and the print storage special feature.

Off. This is the normal setting of the auxiliary mode switch. In this position, the switch is not functional.

Full Storage Print. When a 1401 system is equipped with an IBM 1406 Storage Unit, this position is used with the main mode switch to print the contents of all the storage positions. To accomplish this:

1. Set the auxiliary mode switch to FULL STORAGE PRINT.
2. Set the mode switch (1401 console) to STORAGE PRINT OUT.
3. Press the start key.

Printing starts at position 001 and continues until all positions in storage have been printed. Word marks print as 1's under the corresponding data positions.

Print Storage Scan. When a 1401 system has the print storage special feature, this position is used with the main mode switch to scan the 132 print storage positions, and the core storage print area (positions 201 through 332). To accomplish this:

1. Set the auxiliary mode switch to PRINT STORAGE SCAN.
2. Set the mode switch (1401 console) to STORAGE SCAN.

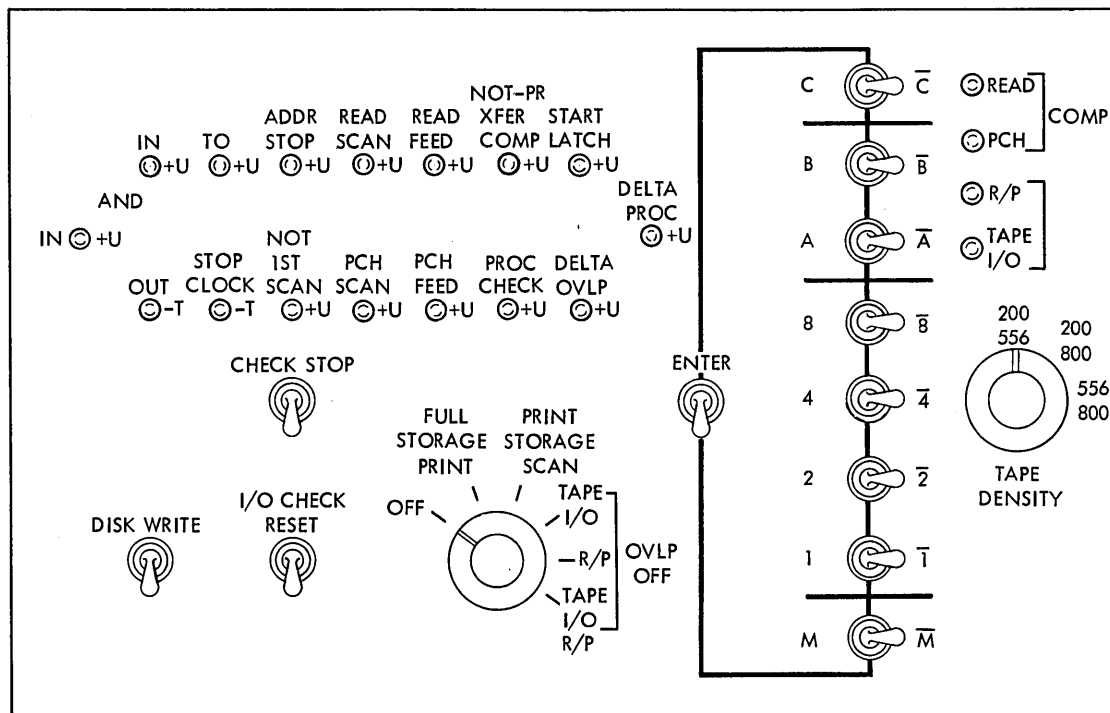

Figure 196. Auxiliary Console

3. Press the start key.

Scanning begins at position 201 of core storage, and the first position of print storage, and continues through 132 positions in each area. During this procedure, the contents of the main storage print area are displayed in the B-register, and the contents of the print storage area are displayed in the A-register.

If an error is found in either register, scanning stops; otherwise, it stops at position 332. After an error stop, resetting error condition and pressing the start key allows scanning to continue.

Tape I/O. This switch setting prevents magnetic tape or serial input-output operations from being performed in the overlap mode. It is used primarily by customer engineering (see *Note*).

R/P (Read-Punch). This switch setting prevents card operations from being performed in the overlap mode. It is used primarily by customer engineering.

Tape I/O R/P. This switch setting prevents card, tape, or serial input-output operations from being performed in the overlap mode. It is used primarily by customer engineering (see *Note*).

NOTE: With the switch in either the **TAPE I/O** or **TAPE I/O R/P** positions, tape operations are not performed in the overlap mode. Therefore, to store the address of the last position of a tape operation, a store B-address register operation must be performed. Storing the contents of the O-address register is incorrect.

729 V DENSITY SWITCH

This three-position switch controls the low- and high-density rates of the IBM 729 V Magnetic Tape Units attached to the 1401 system. The three settings are 200-556, 200-800, and 556-800.

The IBM 729 II, 729 IV, and 7330 Magnetic Tape Units operate at either 200 or 556 characters-per-inch regardless of the tape-density switch setting. For example, if a 729 II tape unit is addressed for operation and the tape-density switch is set at the 556/800 position, the tape unit operates as if the switch were set at the 200/556 position. An IBM 729 V Magnetic Tape Unit, attached to the system, assumes the recording density actually designated by the tape-density switch.

DISK WRITE SWITCH

The disk write switch facilitates testing programs on an IBM RAMAC 1401 system. It prevents writing test data on permanent records in disk storage. When the switch is ON, normal disk storage operations can be performed.

When this switch is OFF, all disk storage instructions, with exception of **WRITE DISK** and **WRITE DISK WITH WORD MARKS**, are performed normally. When these two instructions are encountered, the switch prevents the transfer of data from core storage to the disk surface. Automatic comparison of the record address in core storage and the address on the disk record is performed, however, and the unequal-address compare indicator turns ON if an unequal condition occurs.

Note: A **WRITE DISK CHECK** instruction must be performed following a write operation, regardless of the setting of the disk write switch. Because the record data in core storage is not written on the disk, a read-back check occurs each time a write check operation is performed.

SYNC. POINTS

Ten test points and two rectifier circuit points are made available to simplify the servicing of the system. These points are only for the use of customer engineering.

IBM 1402 Card Read-Punch Operating Keys, Lights, and Switches

START KEY

This key is used to initiate machine operation after a manual, programmed, or automatic stop (Figure 197).

STOP KEY

This key is used to stop the system. If a program step is in process, it is completed before the stop occurs.

NON-PROCESS RUN-OUT READ KEY

This key is pressed to clear the read feed. The last two cards in the normal stacker have not been processed.

NON-PROCESS RUN-OUT PUNCH KEY

This key is pressed to clear the punch feed. The last two cards in the normal stacker have not been punched, and the third-from-last card has not been checked.

LOAD KEY

This key is used to start loading instruction cards. Pressing the load key operates the read feed until a card has passed the read station. The I-address register is set to 001, and a word mark is set in address 001. All other word marks in addresses 002 through 080 are removed.

When the card is read at the read and check station, the program starts and executes the instruction that is punched in the first columns of the card.

Continued operation is completely under control of any program in that card of succeeding cards, as conditioned by the first instruction in the first card. When the punch switch is ON, pressing the load key also starts the punch.

CHECK RESET KEY

This key must be pressed to reset any error indication by a punch, read, or validity check, before the start key can become effective. This key is not effective until the feed unit in error is cleared of cards.

PUNCH SWITCH

This switch controls the *punch* unit of the machine. When this switch is OFF, the punch is inoperative. When it is ON, the machine operates if all the interlock circuits in the punch are satisfied.

READ SWITCH

This switch controls the read section of the machine. When this switch is OFF, the read feed is inoperative.

POWER ON LIGHT

When power is supplied to the read-punch unit, the power-on light is ON.

READER STOP LIGHT

A feed failure, a card jam, a clutch failure, or pressing the reader non-process run-out key stops the machine and turns the reader stop light ON.

PUNCH STOP LIGHT

A feed failure, a card jam, a clutch failure, or pressing the punch non-process run-out key stops the machine, and turns the punch stop light ON.

VALIDITY LIGHT

This light is ON, if an invalid character is detected during a read operation.

READ CHECK LIGHT

This light is ON if a hole-count error is detected during card reading. If the count from the read check and read stations for a given card do not agree, the read check light indicates an error. The light also comes ON if read release time is over-extended.

PUNCH CHECK LIGHT

This light is ON if an unequal hole count is detected in the punch unit or if a B-register error occurs during a punch scan. It also comes ON if the A-register detects an improper character or if punch-release time is over-extended.

TRANSPORT LIGHT

This light turns ON to indicate a card jam in either feed. The light turns OFF when the card jam is cleared.

STACKER LIGHT

If any of the five stackers become full, the machine stops, and this light signals the operator.

FUSE LIGHT

When a fuse in the card read-punch burns out, this light signals the condition.

CHIP LIGHT

When the chip box is full or not properly positioned this light comes on and the machine interlocks. It turns OFF by resetting the chip switch, when the cover is opened to empty the chip box.

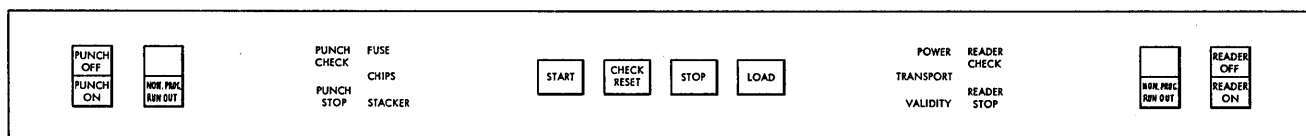

Figure 197. IBM 1402 Keys, Lights, and Switches

IBM 1403 Printer Operating Keys, Lights, and Switches

Printer Controls

These controls are shown in Figure 198.

START KEY

This key starts the machine. There is a duplicate start key located at the rear of the printer for operator convenience (Figure 199).

CHECK RESET KEY

This key is used to reset a printer error indication. The start key is then pressed to resume operation.

STOP KEY

This key stops the machine at completion of the instruction in process. There is also a duplicate stop key at the rear of the machine for operator convenience.

END OF FORMS LIGHT

This light shows an end-of-form condition, and the machine stops.

If an end-of-forms condition occurs during a skip from one form to another form, the skip in the process of being performed is completed, but printing does not occur.

The operator must then determine the tape channel to which the skip was directed. The new form should

be inserted and aligned at the skipped-to channel. After properly inserting the new forms (see *Forms Insertion*), press the start key to resume normal operation. Printing occurs on the proper (skipped-to) line.

If an end-of-form occurs during a skip, or while spacing within the last form in the printer, the operator should single-cycle print until a skip to the next form occurs. When the last form is skipped out, follow the same procedure described for inserting and determining the first printing line on a new form.

FORMS CHECK LIGHT

This light indicates paper feed trouble in the forms tractor. This light turns OFF when corrective action is taken, and the check reset key is pressed.

READY LIGHT

This light turns ON when the printer is in condition to print.

PRINT CHECK LIGHT

This light indicates a print error.

SYNC CHECK LIGHT

This light turns ON to show that the chain was not in synchronism, at all times, with the compare counter for the printer. The timing is automatically corrected. The light is extinguished by pressing the check-reset key.

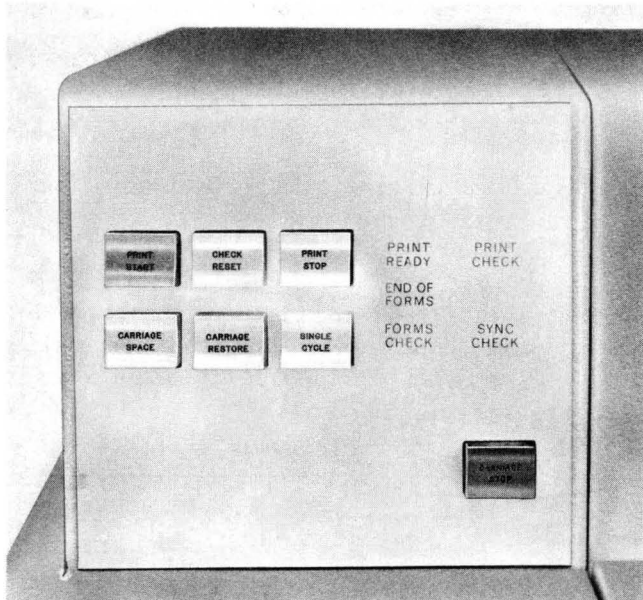

Figure 198. IBM 1403 Printer Operating Keys and Lights

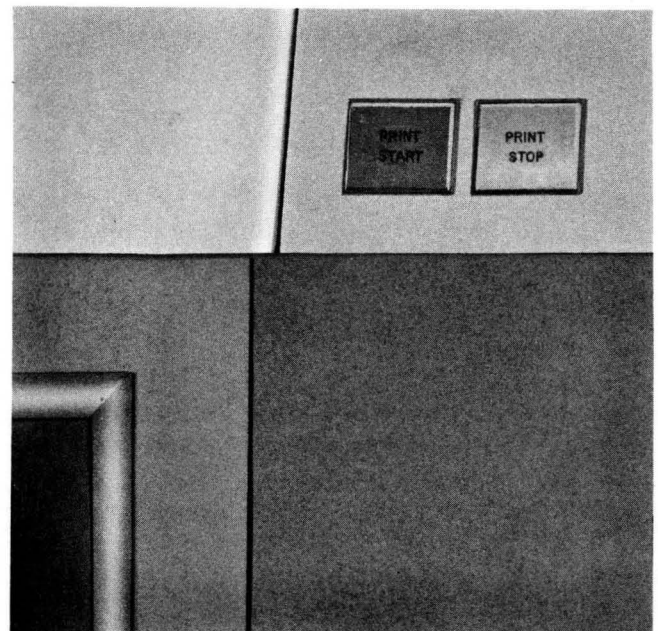

Figure 199. Printer Keys (Rear)

Carriage Controls

The carriage controls are shown in Figure 198.

CARRIAGE RESTORE KEY

Pressing this key positions the carriage at channel 1 (*home position*). If the carriage feed clutch is disengaged, the form does not move. If it is engaged, the form moves in synchronization with the control tape.

CARRIAGE STOP KEY

Pressing this key stops carriage operation.

CARRIAGE SPACE KEY

Each time it is pressed this key causes the form to advance one space.

SINGLE CYCLE KEY

This key initiates the operation of the printer for one print cycle on each pressing of the key. If the end-of-form light is ON, pressing this key causes printing until channel 1 in the carriage tape is sensed.

Manual Controls

The manual controls are shown in Figure 200.

FEED CLUTCH

The feed clutch controls the carriage-tape drive and form-feeding mechanism. If it is set to neutral, automatic form-feeding cannot take place. It is also used to select six- or eight-lines-to-the-inch spacing.

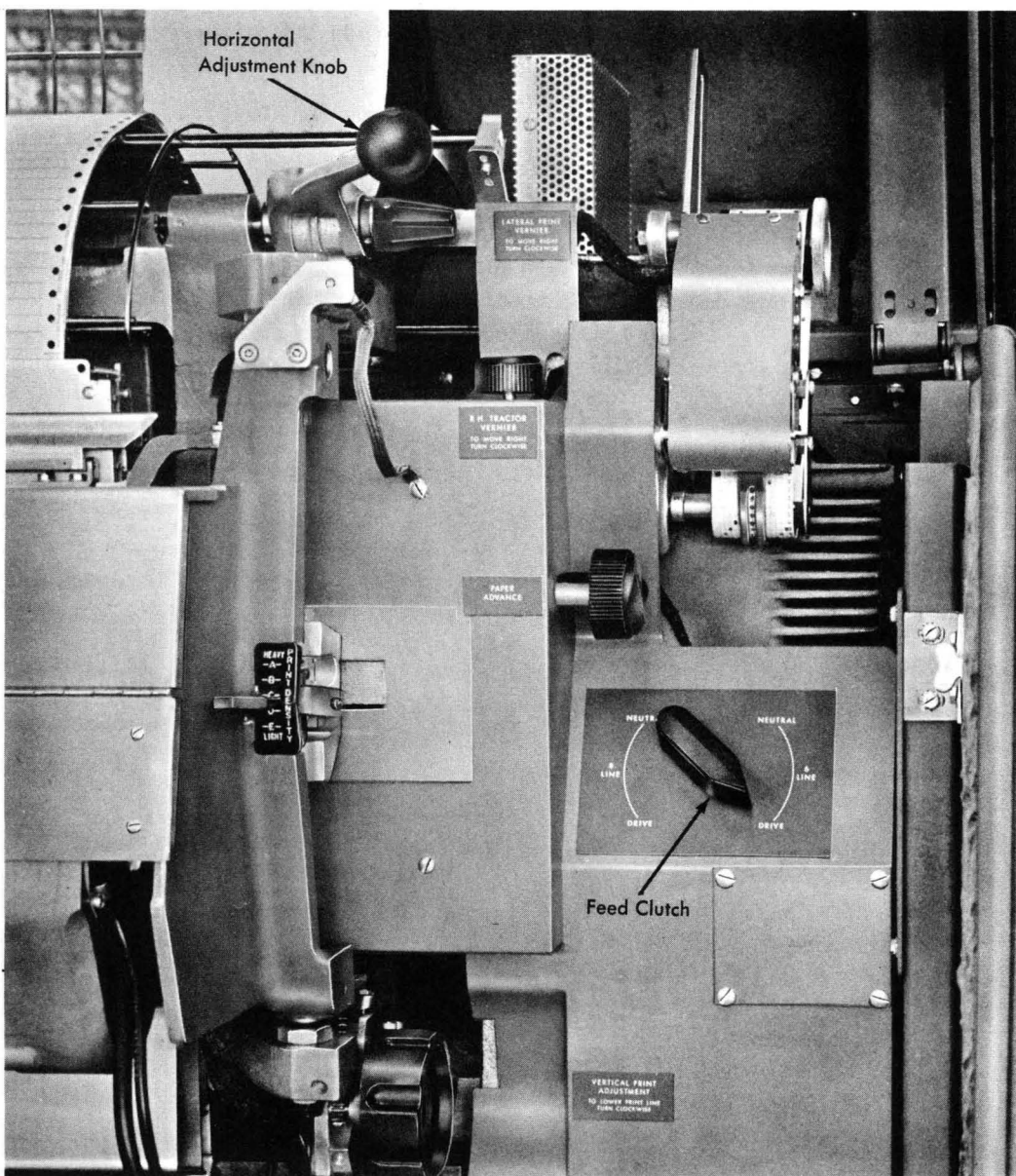

Figure 200. Manual Controls

Page 120 – Single-Cycle Key, replace with:

Each pressing of this key causes an additional line to print, provided either of the following conditions is met:

1. A print operation is set up, and end-of-form and tape channel 1 are not sensed.
2. A print operation is set up, and end-of-form has occurred. This permits printing on the remainder of the form that was being printed when the form check was detected.

PAPER ADVANCE KNOB

This knob positions the form vertically. It can be used only when the feed clutch is disengaged.

VERTICAL PRINT ADJUSTMENT

This knob makes possible fine spacing adjustments of forms at the print line. Carriage tape is not affected by this knob.

LATERAL PRINT VERNIER

This knob permits fine horizontal positioning.

PRINT-DENSITY CONTROL-LEVER

As many as six forms can be printed at one time, and the print hammer unit is designed to adjust automatically for different thicknesses of forms. However, to provide a vernier control for print impression, a print-density control-lever is used. When this lever is set at position E, print impression is lightest. When this lever is set at position A, print impression is darkest. Between these two settings are intermediate settings. Position C is considered the normal setting. This lever moves the type chain closer to or farther from the hammer unit (Figure 200).

The setting of this lever must be considered together with the form's thickness, to determine the normal setting of the print timing dial. A chart is provided to determine this normal setting.

PRINT-TIMING DIAL

A movable-dial is set to a fixed indicator and is used for fine adjustment of printing quality (Figure 201).



Figure 201. Print-Timing Dial and Print-Unit Release Lever

The proper setting of the timing dial is obtained from the print timing dial chart (Figure 202) located on the ribbon cover. The dial is set by using the data on the chart. The setting of the print density lever, in conjunction with the thickness of the form, refers to a nominal setting of the print timing dial which can be read from the print timing dial chart.

The setting from the chart can be adjusted to a finer degree by the operator. For a finer setting of the timing dial, turn the timing dial clockwise till printing of characters on the left side of the form becomes light. Then rotate the dial counterclockwise till the printing of the characters on the right side of the form becomes light. The optimum setting of the print timing dial is halfway between the two readings.

PRINT UNIT RELEASE LEVER

This lever permits access to the form transport area (Figure 201).

PRINT LINE INDICATOR AND RIBBON SHIELD

The lower ribbon shield is also used as a print line indicator. It pivots along with the ribbon mechanism. The front side of this shield is marked to show print position location (Figure 203).

When used as a print line indicator, the ends of the shield indicate where the lower edge of characters will print.

When the printer frame is open, the indicator pivots against the forms so that the print line can be set.

HORIZONTAL ADJUSTMENT

This device positions the printing mechanism, horizontally. When the lever is raised, the print mechanism unlocks, and can be positioned horizontally within its 2.4-inch travel limit.

R. H. TRACTOR VERNIER

This knob allows for fine adjustments in paper tension. It can be used for adjustments of up to one-half inch.

Tractor Slide Bar: There are two tractor slide bars, upper and lower. The forms tractors are mounted on

		PRINT TIMING DIAL SETTING							
		FORM THICKNESS							
		003	006	009	012	015	018	021	024
P R I N T Y	A	21	18	15	12	9	6	3	0
	B	25	22	19	16	13	10	7	4
	C	29	26	23	20	17	14	11	8
	D	33	30	27	24	21	18	15	12
	E	37	34	31	28	25	22	19	16

OBTAIN DIAL SETTING BY MATCHING "FORM THICKNESS" TO "PRINT DENSITY"

Figure 202. Print-Timing Dial Chart

these bars. The forms tractors are movable, and to facilitate this movement there are notches in the tractor slide bar. A description of the use of these notches for proper adjustment for the form to be used is given for the upper tractor slide bar. The description would be the same for the lower slide bar.

The left hand tractor is locked in place by a spring-loaded latch in one of the nine notches located one inch apart on the tractor slide bar. The third notch from the left end is the normal location for most applications.

The first notch is used for forms from $5\frac{1}{2}$ to $18\frac{3}{4}$ inches wide. When this notch is used, the print unit's lateral movement is limited to .4 inch.

The second notch is used for forms from $4\frac{1}{2}$ to $17\frac{3}{4}$ inches in width. When this notch is used, the print unit's lateral movement is limited to 1.4 inch.

The third notch is used for forms from $3\frac{1}{2}$ to $16\frac{3}{4}$ inches wide. When this notch or notches 4

through 9 are used, full lateral print unit movement (2.4 inches) is possible.

The ninth (last) notch can be used for forms from $3\frac{1}{2}$ to $10\frac{3}{4}$ inches wide. When this notch is used, the first usable print position is 38.

The right-hand tractor is locked in place by spring-loaded pins snapped into any one of 27 holes, located one-half inch apart on the tractor slide bar.

The movement of the tractor slide bar, in which the holes are located, is controlled by the right hand tractor vernier. Movement of up to $\frac{1}{2}$ inch can be made by using the vernier knob.

Indicator Panel Lights

Gate Interlock: This light is turned on when the print unit is not locked in position (Figure 204).

Brush Interlock: This light is on if the carriage tape brushes are not latched in position for operation.

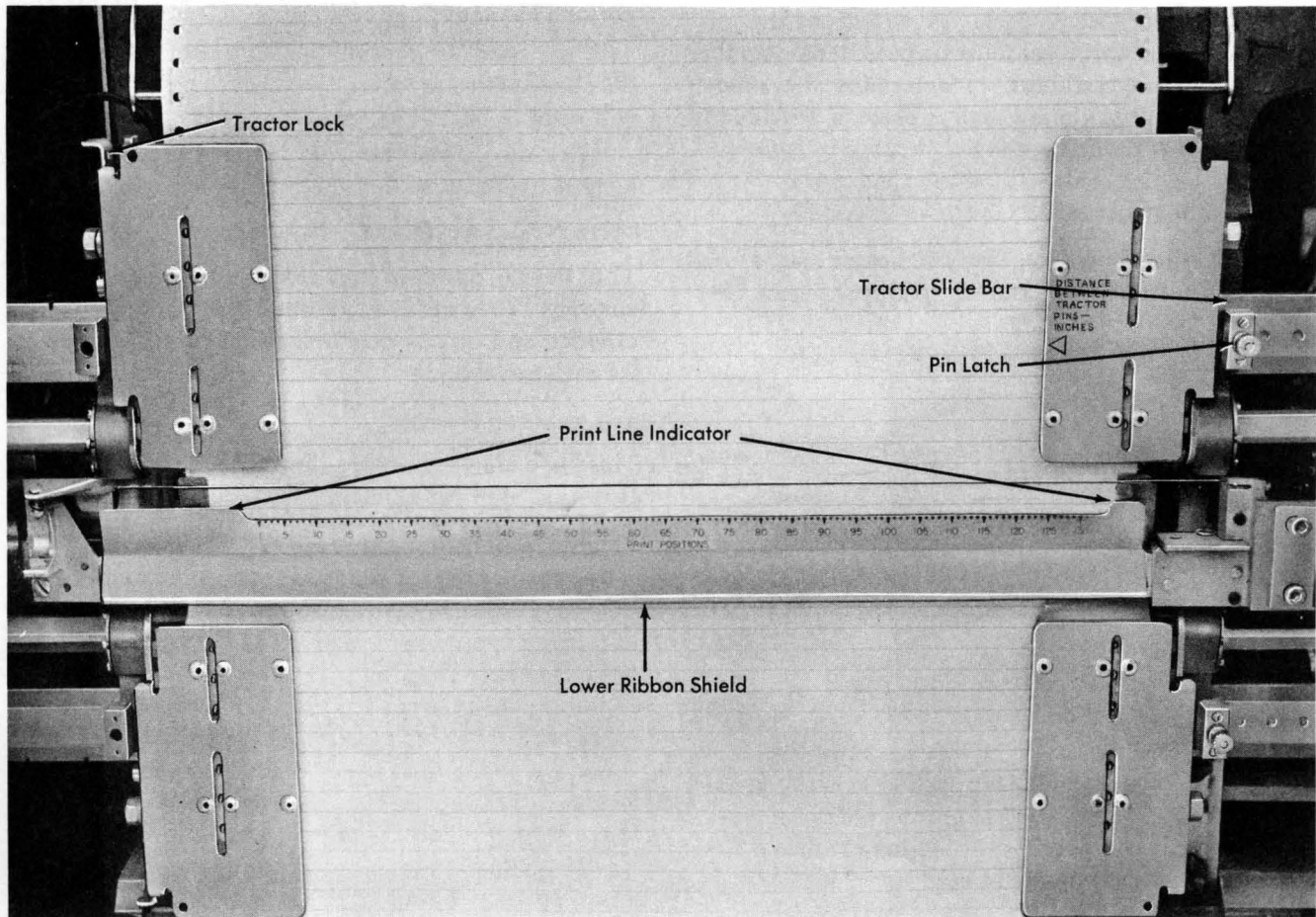

Figure 203. Print-Line Indicator and Ribbon Shield

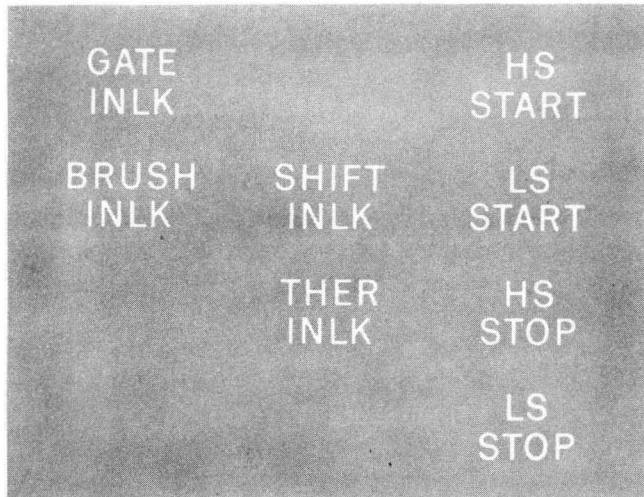

Figure 204. Printer Indicator Panel

Shift Interlock: This light turns on to indicate that the manual feed clutch is not properly positioned.

Thermal Interlock: This light turns on to indicate that a thermal unit has caused a fuse to burn out. If it is on, the IBM customer engineering department should be notified.

High Speed Start: This light turns on when a high-speed skip has been initiated.

Low Speed Start: This light turns on when a low-speed skip or line spacing has been initiated.

High Speed Stop: This light turns on to indicate that high-speed skipping is to be stopped.

Low Speed Stop: This light turns on to indicate that a low-speed skip stop has been initiated. It is on when the carriage is not in motion.

Tape-Controlled Carriage

The tape-controlled carriage (Figure 205) controls high-speed feeding and spacing of continuous forms. The carriage is controlled by punched holes in a paper tape that corresponds in length to the length of one or more forms. Holes punched in the tape stop the form when it reaches any predetermined position.

Forms skip at a rate of 33 inches per second. With the dual-speed carriage, distances of less than eight

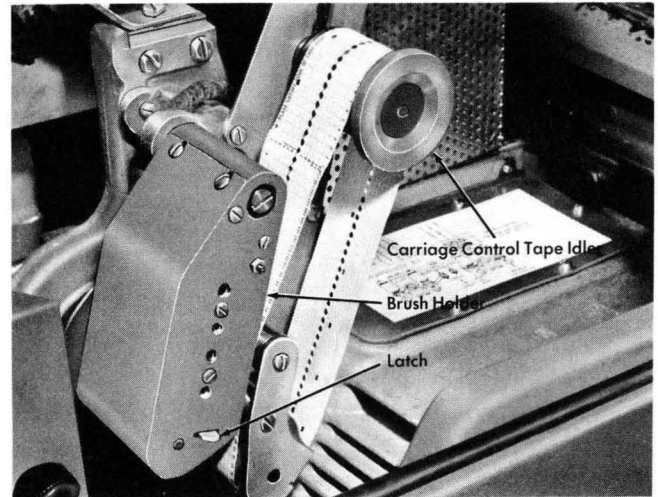

Figure 205. Tape-Controlled Carriage

lines are skipped at 33 inches per second, and those of more than eight lines at 75 inches per second. The last eight spaces skipped in a high-speed skip are skipped at 33 inches per second.

The carriage accommodates continuous forms, up to a maximum of 22 inches in length (at 6 lines per inch) or 16½ inches (at 8 lines per inch). The minimum length is 1 inch. For efficient stacking of forms, the recommended maximum forms length is 17 inches. The width of the form can vary from a recommended minimum of 3½ inches to a maximum of 18¾ inches, including punched margins.

Forms can be designed to permit printing in practically any desired arrangement. Skipping to different sections of the form can be controlled by the program and by holes punched in the carriage tape.

Control Tape

The control tape (Figure 205) has 12 columnar positions indicated by vertical lines. These positions are called channels. Holes can be punched in each channel throughout the length of the tape. A maximum of 132 lines can be used to control a form, although for convenience, the tape blanks are slightly longer. Horizontal lines are spaced six to the inch for the entire length of the tape. Round holes in the center of the tape are pre-punched for the pin-feed drive that advances the tape in synchronism with the movement of a printed form through the carriage. The effect is exactly the same as though the control holes were punched along the edge of each form.

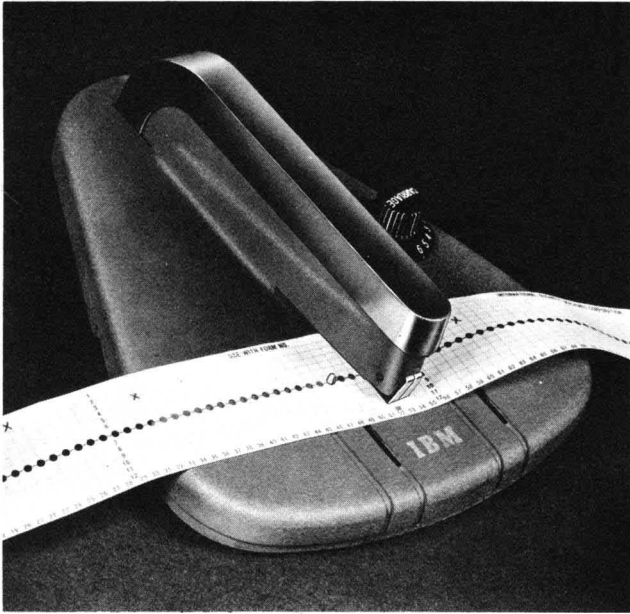

Figure 206. Tape Punch

PUNCHING THE TAPE

A small, compact punch (Figure 206) is provided for punching the tape. The tape is first marked in the channels in which the holes are to be punched. This can be done easily by laying the tape beside the left edge of the form it is to control, with the top line (immediately under the *glue* portion) even with the top edge of the form. A mark is then made in the first channel, on the line that corresponds to the first printing line of the form. Additional marks are made in the appropriate channels for each of the other skip stops, and for the overflow signal required for the form.

The marking for one form should be repeated as many times as the usable length of the tape (22 inches) allows. With the tape thus controlling several forms in one revolution through the sensing mechanism, the life of the tape is increased. Finally, the line corresponding to the bottom edge of the last form should be marked for cutting after the tape is punched.

The tape is inserted in the punch by placing the line to be punched over a guide line on the base of the punch and placing the center feed holes of the tape over the pins projecting from the base. The dial is then turned until the arrow points at the number of the channel to be punched. Pressing on the top of the punch, toward the back, cuts a rectangular hole at the intersection of a vertical and horizontal line in the required channel of the tape. The tape should never be punched in more than one channel on the same line. Holes in the same channel should not be spaced closer than 8 lines apart. After the tape is punched, it is cut and looped into a belt. The bottom

end is glued to the top section, marked *glue*, with the bottom line coinciding with the first line. Before the tape is glued, the glaze on the tape should be removed by an ink eraser; if this is not done, the tape ends may come apart. The center feed holes should coincide, when the two ends of the tape are glued together.

The last hole punched in the tape should be at least four lines from the cut edge, because approximately the last half inch of the tape overlaps the *glue* section when the two ends are spliced. If it is necessary to punch a hole lower than four lines from the bottom of the form, the tape should be placed with the top line (immediately under the *glue* portion) four lines lower than the top edge of the form, before making the channels. To compensate for the loss, the tape should then be cut four lines lower than the bottom edge of the form.

8-Lines-per-inch Spacing

The control tape for 8-lines-per-inch spacing is punched as it would be for normal 6-lines-per-inch spacing. Each line on the tape always equals one line on the form, regardless of whether the latter be 6 or 8 lines-per-inch. In measuring a control tape for a document printed 8 lines to the inch, every $\frac{1}{8}$ inch on the form represents one line on the tape.

Carriage Tape Brushes

Two sets of reading brushes (Figure 207) mounted on the same frame, are used to sense holes in the carriage control tape. A small contact roll is used for each set of brushes. One set is called the *slow brushes*. The other set is called the *stop brushes*. Seven spaces, as measured by the control tape, separate the brush sets. The slow brushes are positioned ahead of the stop brushes.

The slow brushes are used to control high-speed skipping. They regulate the speed of the last eight spaces of a high-speed skip.

All carriage tape brushes can function to stop a carriage skip under control of the stored program.

Inserting Control Tape in Carriage

1. Raise the counter-balanced cover of the printer to gain access to the tape-reading mechanism.
2. Turn the feed clutch knob to a disengaged position (see Figure 200).
3. Raise the brushes by moving to the left the latch located on the side of the brush holder.

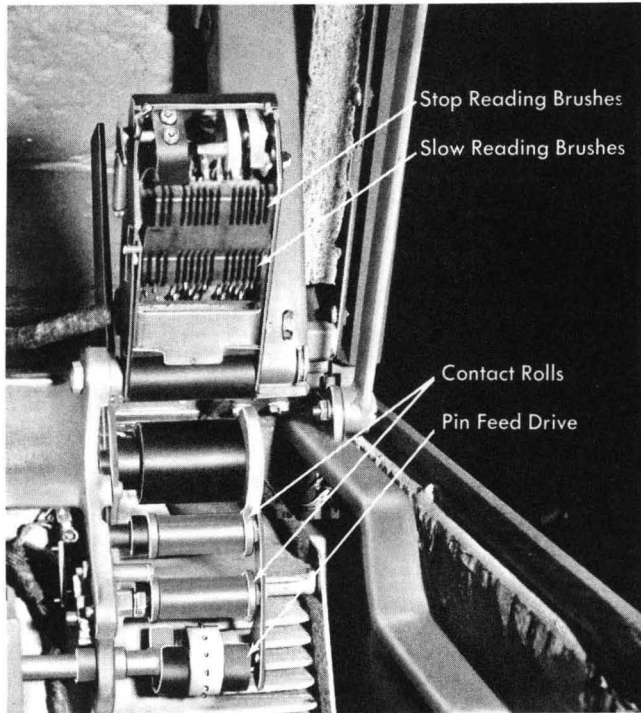

Figure 207. Carriage Tape Brushes

4. Place one end of the tape loop, held so that the printed captions can be read, over the pin-feed drive wheel so that the pins engage the center drive holes.
5. Place the opposite end of the loop around the adjustable carriage control tape idler.
6. Remove the excess slack from the tape by loosening the locking knob on the idler and moving the idler in its track. Tighten the knob when the desired tension is reached. The tape should be just tight enough so that it gives slightly when the top

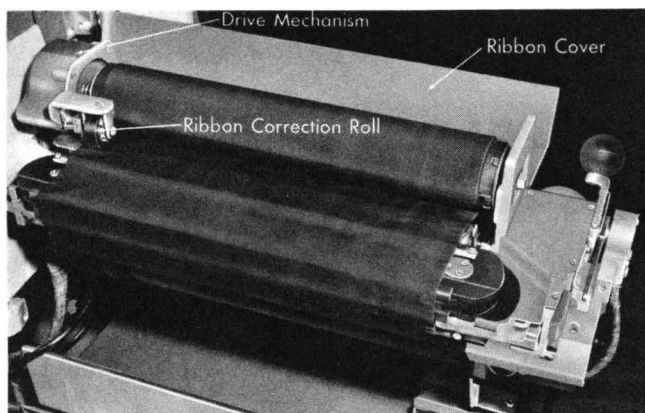

Figure 208. Ribbon Mechanism

and bottom portions of the loop are pressed together (see Figure 205). If it fits too tightly, damage occurs to the pin-feed holes.

7. Press the brushes down until they latch, and close the printer cover, when the tape is in position.
8. Press the carriage restore key to bring the tape to its home position, and turn the feed clutch knob back to the engaged position. The carriage is ready to operate.

Ribbon Changing

To change the ribbon (Figure 208) on the IBM 1403 Printer:

1. Turn off the power in the printer.
2. Lift up the printer cover.
3. Pull back and unlock the print unit release lever. Swing the print unit out.
4. Open the top ribbon cover.
5. Unlatch the print-line indicator ribbon shield and swing it against the form.
6. Push the top ribbon roll to the right (hinged side of print unit), lift out the left end of the ribbon roll, and remove roll from the drive end of mechanism.
7. Slip the ribbon out from under the ribbon correction roll.
8. To remove the bottom roll, press the ribbon roll to the right, and lower the left end of the ribbon roll and remove it from the drive end of the mechanism.

When replacing the ribbon in the machine, hand-tighten the ribbon to remove slack from in front of the printing mechanism. Ribbons are available in widths of 5, 8, and 11 inches in addition to the standard 14 inches. The ribbon width lever (Figure 209) can adjust the ribbon-feed mechanism to accommodate the various ribbon widths.

Note: When installing a new ribbon in the printer, always load the full ribbon spool on the bottom spindle to assure proper ribbon skew on the first winding of the ribbon (Figure 210).

Forms Insertion

1. Raise the counterbalanced cover of the printer to gain access to the print and forms area.
2. Turn the feed clutch knob to a neutral position.

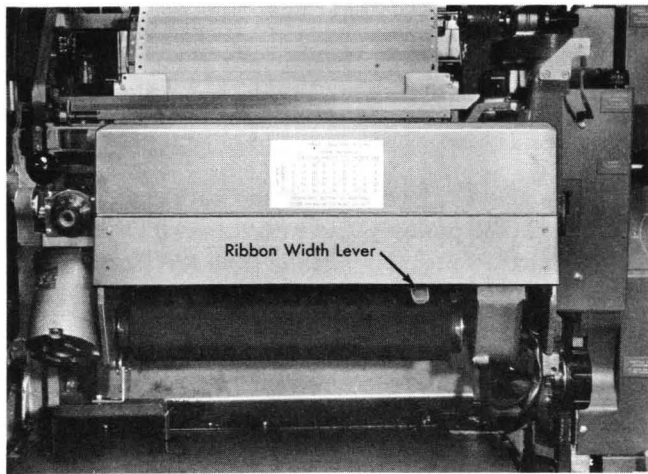

Figure 209. Front Cover Open

3. Unlock and swing back the print unit by using the print unit release lever.
4. Open the upper and lower forms tractors (Figure 211).
5. Set the left forms tractors slightly to the left of the first unit position by pulling up or down in the tractor lock (upper and lower tractor). See Figure 203.
6. Insert form on pins and close tractor cover.
7. Pull out on right tractor pin and move tractor to desired location to line up the right side of form. The pin should latch in one of the recessions in the tractor slide bars. See Figure 203.
8. Insert form on pins and close tractor covers.
9. Use the tractor vernier knob to tighten the tension on the form. This knob is used for adjustments of up to one-half inch.
10. Check the position and line where printing will occur, by swinging the ribbon shield against the

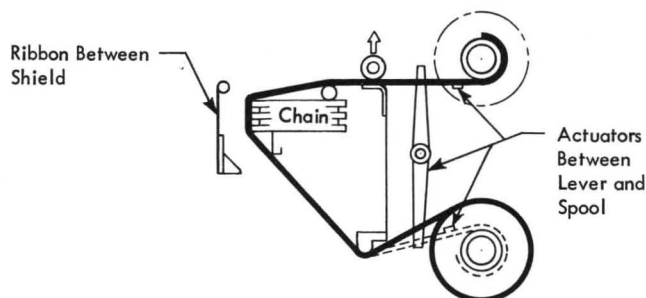

Figure 210. Installing a New Ribbon

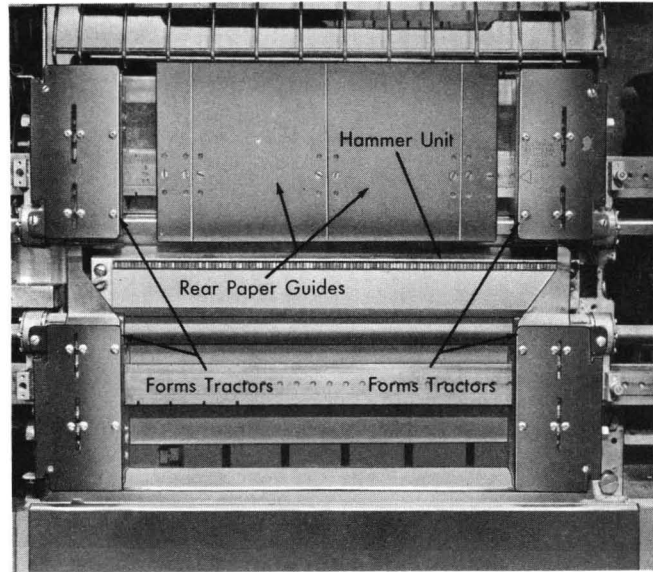

Figure 211. Forms Tractor

- form (it is marked with each print position). If the horizontal alignment is not correct, it can be adjusted by using the horizontal adjustment knob and/or the lateral print vernier knob for slight adjustments. The vertical adjustment can be made by using the paper advance knob and/or vertical print adjustment knob.
11. Return the print unit to its normal position and lock it in place.
12. Restore the carriage tape to the first printing position by pressing the carriage restore button.
13. Return the feed-clutch knob to a drive position at either six or eight lines-per-inch, depending on the form to be printed.
14. Close the outside cover of the printer.

Paper Stacker

The paper stacker provides a manual control for optimum stacking of paper at the rear of the printer. Two controls (Figure 212) permit the operator to set up the paper stacker for each individual run.

The upper lever controls the position of the paper guide at the stacker. This lever is indexed (0-6) so that the setup position can be recorded for reference in the operator's procedures.

The lower lever is a speed control that is set to keep light tension on the paper form feeding into the



Figure 212. Paper-Stacker Controls

stacker. The speed control has five settings. The setting of this control is selected according to the carriage operation being used. For example, if the job is a listing operation with no long skips, the slow position is selected. However, this must also be conditioned by the kind of forms being used because of varying weight of the paper.

Cleaning the Chain

The printing chain on the IBM 1403 Printer should only be cleaned by qualified personnel. When cleaning the chain becomes necessary, a customer engineer should be called to perform the task.

IBM 1405 Disk Storage Unit Indicator Lights

POWER ON LIGHT

When power is supplied to the disk storage unit, the power-on light is ON (Figure 213).

READY LIGHT

This light is ON when the 1405 is available for use in the 1401 system. It goes OFF to indicate either low air pressure, power supply failure, or improper functioning of the reading or writing circuits. When this light goes OFF the RAMAC light on the 1401 console comes ON. Processing can continue until the stored program addresses the disk storage unit. This prevents inaccurate disk storage operation.

PARITY LIGHT

This light comes ON when a parity check occurs as a character is read from, or written on a disk record. This light is reset by pressing the start reset key on the 1401 console or by testing the READ-WRITE PARITY CHECK indicator. The 1401 system does not stop for a parity error.

ACCESS 0-1-2 LIGHTS

These access lights correspond to the addresses of the access arms on the 1405. Each light indicates that the

corresponding access arm has been placed in an inoperable condition by either a logic safety circuit or by a customer engineer. The RAMAC light on the 1401 console turns ON when the access light is ON. An indicator that can be tested by a branch instruction turns ON when the access light comes ON.

RECORD LENGTH LIGHT

This light comes ON when the wrong-length record indicator turns ON. It turns OFF when the indicator turns OFF (see *Branch if Indicator On* instruction for 1405).

ADDRESS COMPARE LIGHT

This light comes ON when the unequal-address compare indicator turns ON. The light goes OFF when the indicator turns OFF (See *Branch if Indicator On* instruction for 1405).

ADDRESS INVALID LIGHT

This light comes ON when an instruction for an access arm or disk storage unit that is not in the system is processed by the 1401. When this light comes on the RAMAC light on the 1401 console turns ON. The system does not stop.

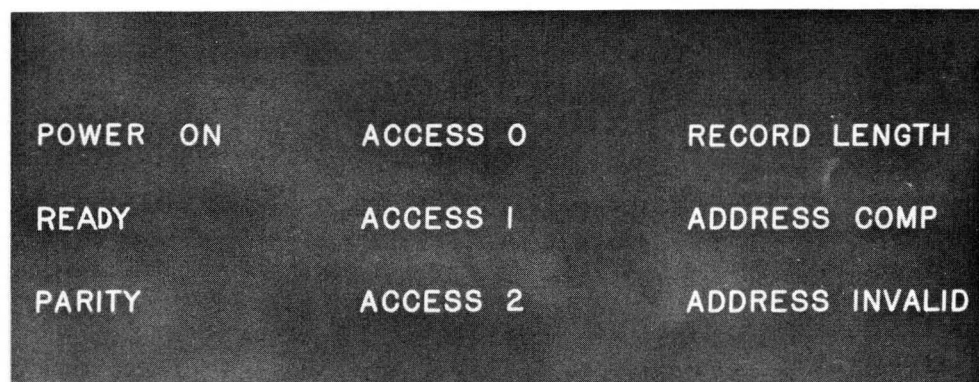

Figure 213. IBM 1405 Indicator Lights

IBM 1407 Console Inquiry Station Keys and Lights

REQUEST/ENTER KEY-LIGHT

If the 1401 is in the RUN mode, pressing this key-light (Figure 214) and the processing of a console instruction causes:

1. the inquiry request indicator to turn ON, and the request light comes ON
2. the enter light to come ON when the 1401 is ready to accept data from the 1407
3. the typewriter keyboard to unlock when a 1407 instruction is processed
4. the inquiry request indicator to turn OFF.

RESPOND/TYPEOUT KEY-LIGHT

If the 1401 is in the RUN mode, and a read-into-storage operation was performed, pressing this key causes:

1. a group-mark with a word-mark to enter 1401 storage
2. the enter light to turn OFF
3. the carriage on the typewriter to return
4. the typewriter keyboard to lock
5. the 1401 program to go to the next program step.

If the 1401 is in the RUN mode, and a write-out-of-storage operation is to be performed by the stored program, the typeout light comes ON when the 1407 begins to type data from 1401 storage.

If the 1401 is in the ALTER mode, and a write-out-of-storage operation is to be performed, pressing this key causes:

1. data from 1401 storage to be typed on the 1407
2. the light to come ON when typing begins.

CLEAR KEY-LIGHT

If the 1401 is in the RUN mode, and a read-into-storage operation has been performed, pressing this key causes:

1. the inquiry clear indicator to turn ON
2. the carriage on the typewriter to return
3. the typewriter keyboard to lock
4. the enter light to turn OFF
5. the 1401 program to go on to the next program step.

If the 1401 is in the RUN mode, and a write-out-of-storage operation is being performed, pressing this key causes:

1. the inquiry clear indicator to turn ON
2. the typeout to stop
3. the carriage on the typewriter to return
4. the respond typeout light to turn OFF
5. the 1401 program to go on to the next program step.

If the 1401 is in a RUN mode, and a read-into-storage operation is being performed, the clear light comes ON and locks the typewriter if a group-mark with a word-mark is sensed in 1401 storage before the end of the read-in operation.

If the 1401 is in the ALTER mode of operation, a read-into-storage operation is being performed, and this key is pressed:

1. the inquiry clear indicator is not affected
2. the read-in operation is cancelled
3. the carriage on the typewriter returns
4. the typewriter keyboard locks.

If the 1401 is in the ALTER mode of operation, a write-out-of-storage operation is being performed and this key is pressed:

1. the inquiry clear indicator is not affected
2. the write-out operation is cancelled
3. the carriage on the typewriter returns.

ALTER KEY-LIGHT

This key-light is operative only if the 1401 is in the ALTER mode of operation. The light comes ON when the mode switch on the 1401 console is in the ALTER position. Pressing the key:

1. signals the 1401 that a 1407 alter operation is to take place
2. causes the 1407 keyboard to unlock
3. causes the enter light to come ON.

WORD MARK KEY

Pressing this key causes a word mark to enter 1401 core storage with the next character typed except during a READ FROM CONSOLE PRINTER instruction. The character with the word mark is typed in red.

FORM KEY LIGHT

This light comes ON when an end-of-forms condition is sensed. Typing stops immediately. Pressing the key, and holding it down, allows typing to resume.

After forms are replaced, pressing the key resets the end-of-forms condition and turns OFF the light.

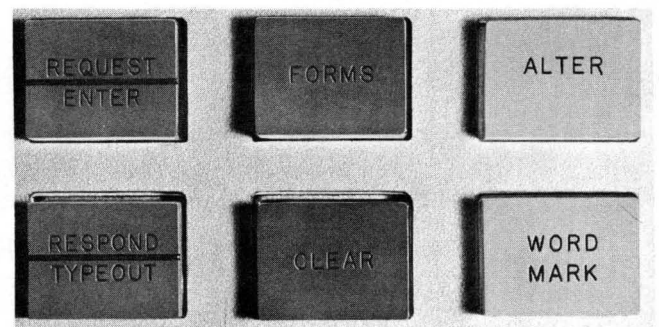

Figure 214. IBM 1407 Keys and Lights

Operating Pointers

This section describes the functional keys and levers of the console printer. Instructions describing console printer setup are also included.

Keys and Levers

IMPRESSION INDICATOR LEVER

This lever (Figure 215) can be moved forward and backward permitting changes to be made in the amount of force with which the type bars strike the paper. The higher the indicator is moved, the harder the type bars strike. To determine the correct setting for each type of work, use the comma and period as a test, adjusting the impression indicator so that they print distinctly but not heavily. As a general rule, use a higher setting for multiple carbon copies.

MARGIN RELEASE KEY

To print beyond the right or left hand margin, press the margin release key and space beyond that point.

TAB CLEAR KEY

To clear a tab stop, space to the point to be cleared and press the tab clear key. To clear all stops at once, move the carriage to the end of the printing line, press the tab clear key, and, while holding it down, press the carriage return key.

TAB SET KEY

To set a tabulator stop, position the carriage and press the tab set key.

MARGIN SET KEY

The margin set key is used to position the left and right margin stops. To reset the left or right margin:

1. Move the carriage to the present margin stop position.
2. Press the margin set key, and, while holding the key down, move the carriage to the new location.
3. Release the margin set key, and the margin stop is repositioned.

Impression and Carriage Control

LINE POSITION RESET

This lever (Figure 216) locks out standard line spacing and provides a free-rolling platen. To return to the regular printing line accurately and automatically, restore the lever to its forward position. The LINE POSITION RESET makes it possible to print above or below the line — double underscore, subscript, superscript, exponent — and then continue with regular printing. Follow these steps: push back the reset lever, roll the platen to the desired place, print. When the reset lever is returned to the forward position, regular spacing is resumed.

CARRIAGE RELEASE BUTTONS

To move the carriage by hand, press either the left or the right carriage release button located on either side of the carriage. (As the left margin is approached, the air-cushioning action that quiets the electric carriage return will be felt.)

PLATEN VARIABLE BUTTON

When the PLATEN VARIABLE is pressed, the platen moves freely backward or forward. It should be used

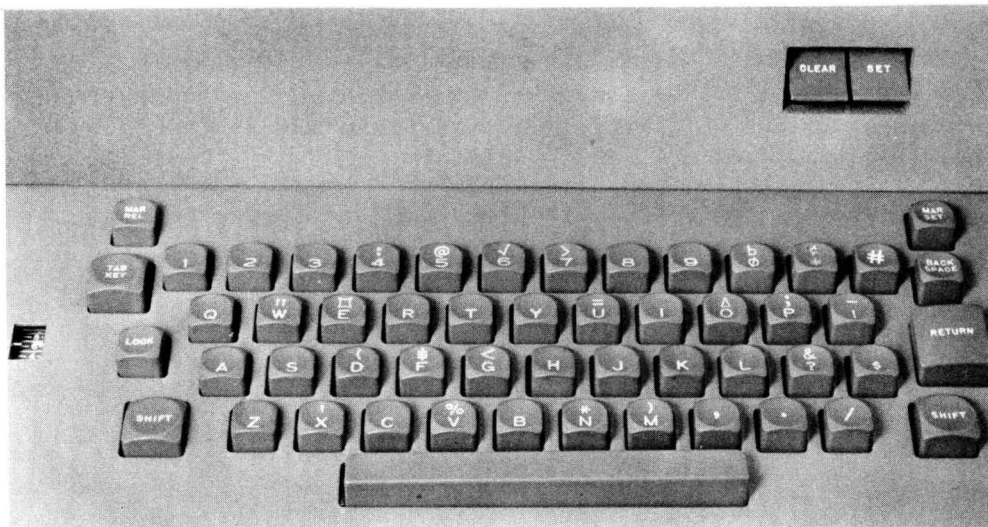

Figure 215. Margin, Tab, and Ribbon Control

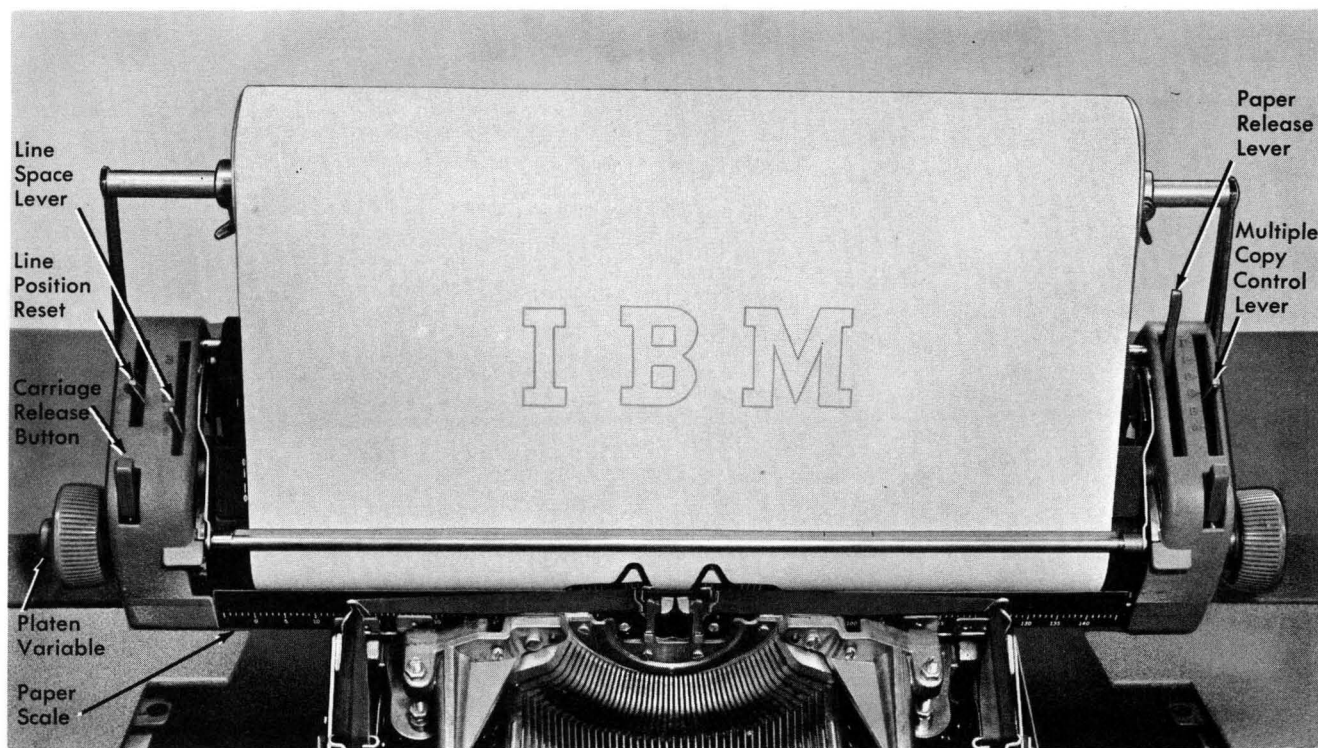

Figure 216. Impression and Carriage Control

when re-inserting a printed page, and it is necessary to locate the same printed line for corrections or additions.

LINE SPACE LEVER

To select single, double, or triple line spacing, move the line space lever to the positions labeled 1, 2, or 3.

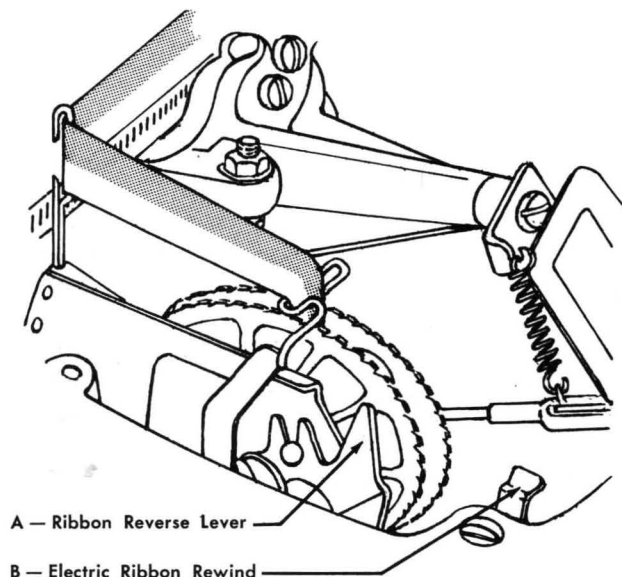

Figure 217. Ribbon Reverse

PAPER SCALE

This scale indicates the position of the carriage and assists in setting margins and tabs accurately.

PAPER RELEASE LEVER

This lever frees the paper for positioning and removal.

MULTIPLE COPY CONTROL LEVER

This lever permits movement of the platen backward or forward to compensate for the thickness of copy paper, allowing the type bar to strike the paper evenly. The weight of paper and carbon paper used are important factors in determining the correct setting. Normally, the multiple copy control lever should be left at A when printing one to four copies. As a general rule, the lever should be advanced one position for every three extra copies (after the first four).

To Reverse a Ribbon

Open the top cover of the console printer by grasping the cover at the center opening and pulling up and away from the console printer. To close, press lightly and the cover will snap shut.

A ribbon reverse lever (Figure 217) is located beside each ribbon spool. These levers reverse the ribbon auto-

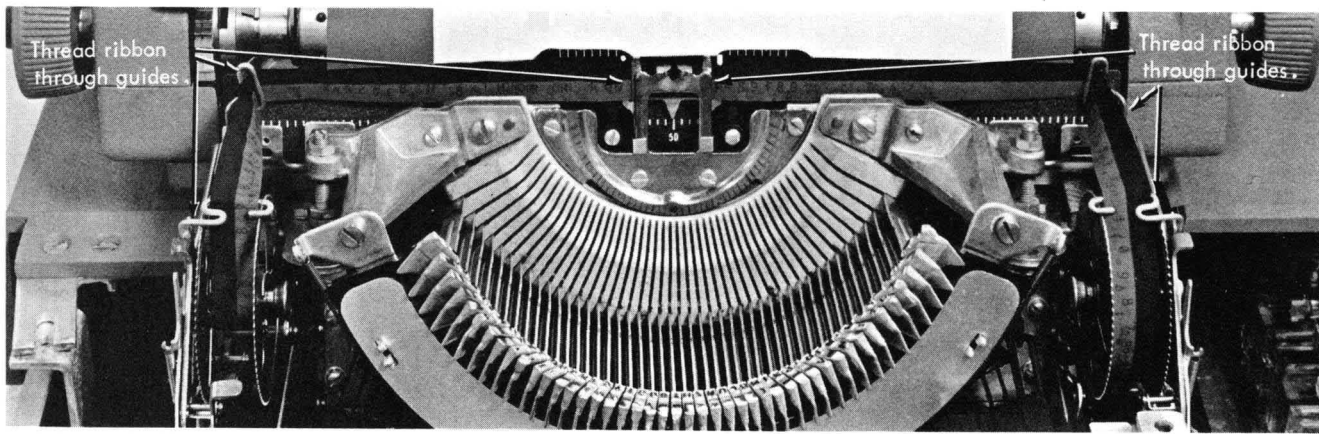

Figure 218. Console Printer Ribbon

matically on either side at the end of the ribbon. The direction of the ribbon can be changed by pressing down on the left-hand lever to wind the ribbon onto the right spool and vice versa.

Press ELECTRIC RIBBON REWIND (Figure 217), and the ribbon is automatically wound onto either spool. (To lock, push down and back.)

To Install a New Ribbon

PRESS ELECTRIC RIBBON REWIND and wind all of the old ribbon onto the spool most nearly filled. Hold back the ribbon guide located over the spool; press the ribbon reverse lever next to the spool; pull out the small knob in the center of the spool. Lift out and discard the used ribbon and spool, and insert a new ribbon making certain the ribbon reverse lever beside this spool is down. Spool teeth on top must point toward the platen. Thread the ribbon through the guides indicated (Figure 218). Hook the end of the ribbon on the hub of the empty spool.

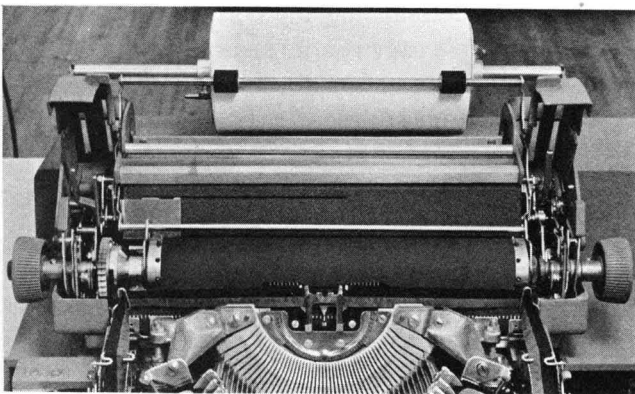

Figure 219. Removing the Platen

Removing the Platen

1. Center the carriage; raise the paper bail, carriage and covers, and copy guide.
2. Push back and lift up latches (Figure 219). Lift out platen.

To replace platen, center the groove in the right platen shaft on the carriage end plate, and bring latches forward and down.

Check these points for proper console printer operation:

1. If the motor and console printer are operating but typebars will not print, make certain that MULTIPLE COPY CONTROL is at A.
2. If the carriage will not move, turn OFF for several seconds, then ON. With switch ON, press the margin release key.

Pin-Feed Platen

A pin-feed platen is standard on the 1407 Console Inquiry Station. The pin-feed platen maintains proper registration and alignment of continuous forms.

The platen is available in three degrees of hardness: hard, medium, and soft. A hard platen should be used whenever forms with five or more parts are used, but it should never be used with less than a five-part form.

Form Feeding

For the best form feeding operation, place the stack of forms directly behind the carriage when it is in the right-hand margin. This allows the forms to align directly behind the carriage at the time that it line spaces.

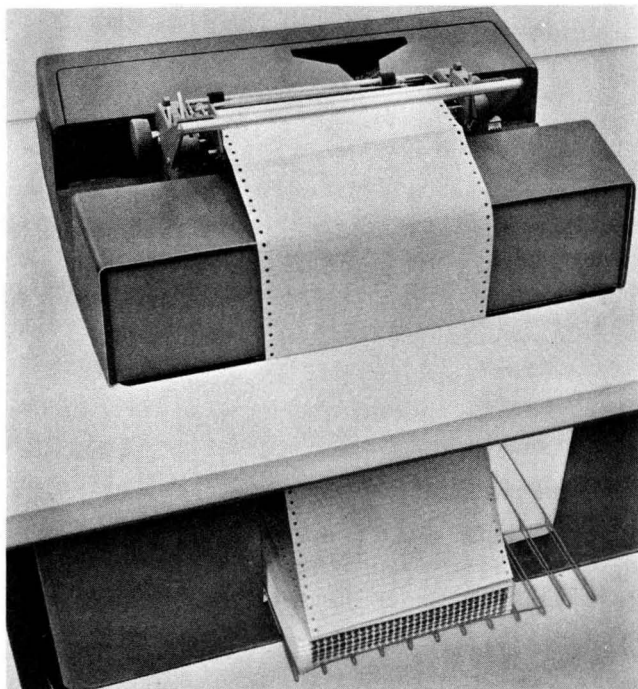

Figure 220. Continuous Forms Feeding

Forms Insertion

Two types of forms feeding can be used on the 1407. One type is roll paper which, attached to the console printer, is shown in Figure 219. The other is continuous forms.

When using continuous forms, the forms are placed on the forms platform. The form is then inserted in a slot between the console printer and the table (Figure 220) and then inserted in the console printer.

The printed forms, in either type of forms-feeding operation, are stacked on the portion of the console inquiry station table behind the console printer.

IBM 729 and 7330 Magnetic Tape Units Operating Keys and Lights

The operating keys and lights of the IBM 729 and 7330 magnetic tape units are located at the top of the unit, above the tape reels (Figure 221). The lights are all on the upper row, and the keys are on the lower row. The address selection dial is at the left.

DENSITY SWITCH

This selects high or low density operation, depending on the tape operating mode desired.

ADDRESS SELECTION DIAL

This dial assigns a number, from 1 to 6, to the tape unit, to identify it to the stored program. If some other number (7, 8, 9, 0, or blank) is set, the tape unit cannot be used by the stored program.

The setting should not be changed when a tape operation is in progress.

SELECT LIGHT

The select light turns ON automatically, when the address selection dial is properly positioned and the unit is addressed by the computer, provided that the unit is ready.

READY LIGHT

This light, when ON, indicates that the tape unit is ready for operation. See *Start Key* for method of turning this light on. The reel door should never be opened when the ready light is ON.

TAPE INDICATE ON LIGHT

This indicator is turned ON by:

1. sensing the end-of-reel marker while writing on tape
2. sensing the tape mark while reading tape.

The indicator may be turned OFF by:

1. pressing the unload key on the tape unit
2. executing a REWIND TAPE AND UNLOAD OR BRANCH IF END OF REEL instruction in the stored program.

FILE PROTECTION LIGHT

This light automatically turns on if the unit is loaded with a reel that does not have the file-protection ring inserted in the back of the reel. The tape cannot be written as long as the file-protection light is ON. This light is ON whenever the tape unit is not in ready status.

FUSE LIGHT

This light turns on automatically whenever a fuse in the unit has blown.

TAPE DENSITY LIGHTS

These two lights (high and low) indicate the density in which the tape unit is operating. They are controlled by the setting of the density switch.

LOAD REWIND KEY

This key is operative only when the reel door is closed and the ready light is OFF. Use of this key, after tape has been properly mounted in the magnetic tape unit, lowers tape into the columns, lowers the head assembly, and moves tape in the rewind direction until the load point reflective spot is sensed. If the reflective spot is not to the right of the read-write head when this key is pressed, the tape will unwind from the machine reel.

Caution: Do not open the reel door during rewind or load point searching.

START KEY

Use of this key places the tape unit in ready status and turns on the ready light, provided that:

1. the reel door is closed

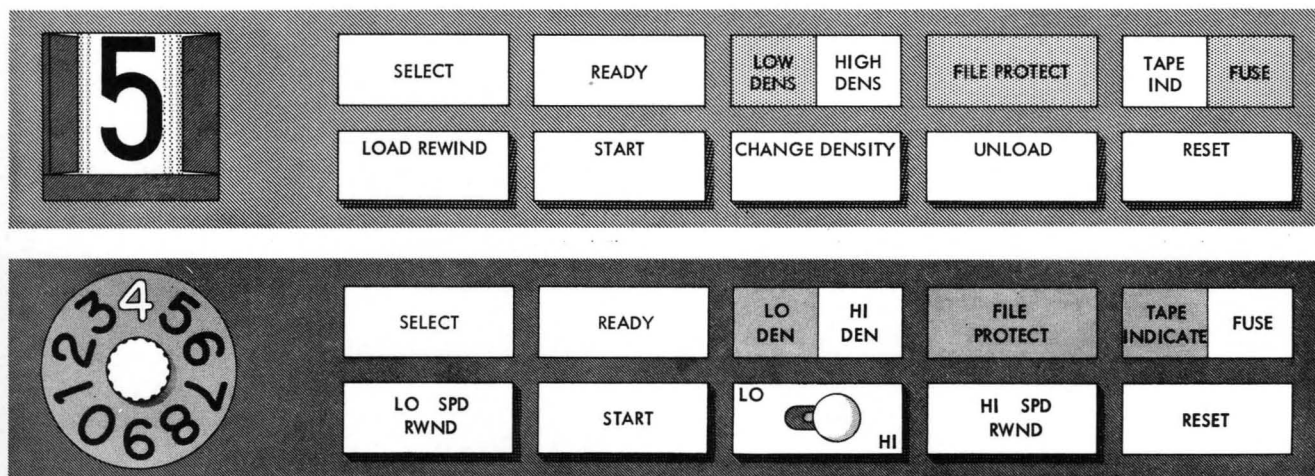

Figure 221. IBM 729 and 7330 Magnetic Tape Units Operating Keys and Lights

2. tape has been loaded into the columns
3. the tape unit is not in the process of finding the load point (rewind or load-point operation).

UNLOAD KEY

This key is operative only when the ready light is OFF, tape is in the vacuum columns, and the reel door is closed. Use of this key raises the head assembly, and removes the tape from the columns, regardless of the distribution of tape on the two reels. If the tape is not at load point when the operator wishes to change tape reels, a load-point search should be initiated first by pressing the load-rewind key. Pressing the unload key also turns off the tape-indicate-on light.

RESET KEY

On a 729 II or IV, this key turns OFF the ready light. It also stops any tape operation except load and unload. If this key is pressed during a high-speed rewind, the operation stops, and then continues as a slow-speed rewind. If the reset key is pressed during a slow-speed rewind, the operation stops.

On a 7330, this key turns OFF the ready light. It also stops any operation being performed. Do not press this key while the 7330 is performing a high-speed rewind. If the key is pressed while the tape unit is performing a high-speed rewind, damage to the magnetic tape results. Press the reset key only after the high-speed rewind has been completed.

REEL DOOR INTERLOCK

When the door is open, the interlock contact prevents any normal operation of the tape unit. The reel door should never be opened when the ready light is ON, or during any load-rewind operation.

REEL RELEASE KEY

When this key is pressed, both reels may be turned manually for threading tape or removing the file reel. To operate the reel release key, open the reel door.

Operating Pointers

Consider the following points whenever a tape unit is in operation.

1. Do not change the address of a tape unit by turning the address selection dial, during the execution of a program that uses other tape units. This applies whether the unit is in ready status or not.
2. Never set two tape units to the same address.
3. Do not open the door of a tape unit unless the tape inside is out of the vacuum columns and the read-write head is raised.
4. If the power in the 1401 goes off with tape units in ready status, have an IBM customer engineer remove the tape from the read-write head and the vacuum columns, of every unit in ready status, before power is restored.

Console Operation

Starting the Machine

The power-on key controls the main power supply for the entire system. Pressing this key has the following results:

1. ac power is supplied to the entire system
2. power light on the reader-punch and ready light on the printer are lighted
3. blowers in the cubes and printer are started
4. dc power is automatically supplied to the system.

Turning Off the Machine

Pressing the power-off key removes the power from the systems:

1. dc power goes OFF
2. ready and power-on lights go out on all units
3. blower motors are turned OFF
4. ac power supply goes OFF.

Entering Information

Information can be entered into a storage location manually as follows:

1. Set the mode switch to ALTER.
2. Set the address of the storage location for information to be entered in the manual-address switches.
3. Set the bit switches on the auxiliary console for the correct BCD code for the information to be entered into the selected storage location.
4. Press the enter key on the auxiliary console.
5. Check B-register bit lights to verify information entered.

Notes. The B-register check light should be OFF. If it is ON, the information entered is not valid.

In some cases the B-register check light gives an error indication on an enter operation if the previous character in the selected area is invalid. Restart with step 4 if the character appears valid but a B-register check is still found.

The storage address bit lights should indicate the storage position selected.

To enter the same character into more than one position of core storage:

1. Set mode switch to storage scan.
2. Set bit switches on the auxiliary console to the desired bit configuration.

Note: Invalid characters can be entered if the check stop switch is off.

3. Hold enter key on auxiliary console.
4. Press the start key.

The process unit continues in the storage scan mode until *both* keys are released.

Manual Display

1. Set mode switch to CHARACTER DISPLAY.
2. Set manual address switches to desired storage location.
3. Press the start key.

Notes. The B-register contains bit configuration for selected location.

The storage address lights display the bit configuration for the address set in the manual address switches.

Check Manual Entry of Address Registers

1. Set mode switch to ALTER.
2. Set manual address switches to the desired address location.
3. Press the I-, A-, or B-address register key.
4. Press the start key.

Note. The storage-display lights show the bit configuration for the particular address register selected in step 3. There should be no error indication.

Console Inquiry Station Operation

Entering Information in Alter Mode

A method of entering data typed on the IBM 1407 into 1401 core storage is:

1. Set the mode switch (1401 console) to ALTER. Alter light on 1407 turns ON.
2. Set the manual address switches (1401 console) to the high-order position in storage, where the typed data is to be placed.
3. Press the B-address register key-light.
4. Press the start key (1401 console) to put the address, set up by the manual address switches, in the B-address register.
5. Press the ALTER key-light (1407 console).
6. The operator can now begin typing the data into 1401 storage beginning at the position specified by setting of the manual address switches. Word marks are cleared from 1401 storage as each character enters from the inquiry station. Characters typed can have an associated word mark entered with them by using the word-mark key.
7. When the transmission is completed, press the clear key (1407 console).
8. To continue programming in the 1401 turn the mode switch to RUN and press the start key (1401 console). If necessary set the address where programming is to begin in the manual address switches (1401 console) and enter it as previously explained.

Read Out of Storage in Alter Mode

A method of transferring an area of 1401 core storage to the 1407 and typing that information is:

1. Set the mode switch (1401 console) to *ALTER*. Alter light (1407) comes *ON*.
2. Set the manual address switches (1401 console) to the high-order position in storage of the data to be typed out.
3. Press the B-address register key-light.
4. Press the start key (1401 console) to set the address set up by the manual address switches in the B-address register.
5. Press the respond/typeout key-light (1407 console). The typeout light comes *ON*.
6. The typewriter prints the data from 1401 storage beginning at the position specified by the setting of the manual address switches. Characters that have a word mark in the same position are typed in red. Blank positions in core storage are printed as lower-case *b*'s.
7. When the transmission is completed, press the clear key.
8. To continue programming in the 1401, turn the mode switch (1401 console) to *RUN* and press the start key (1401 console). If necessary, set the address of the next program step in the manual address switches (1401 console), and enter it as previously explained.

Console Inquiry with IBM 1401 in Run Mode with Inquiry Routine

A method of causing the 1401 program to branch to the inquiry routine and to accept data from the 1407, is:

1. Press the request enter key-light. This turns the inquiry request indicator *ON*.
2. A *BRANCH IF INDICATOR ON* instruction in the 1401 program tests the inquiry request indicator. If the indicator is *ON*, a program branch to the inquiry routine is made and the indicator turns *OFF* when a console inquiry instruction is processed. When the 1401 is ready to accept data from the 1407, the enter key-light is turned *ON*.
3. The operator then types the data to be sent to the 1401. If an error occurs in typing, the clear key is

pressed, turning *ON* the inquiry clear indicator that can be tested by the 1401 program (see *Clear Key*).

4. When the inquiry is completed, press the respond key. This causes the request enter key-light to turn *OFF*, a carriage return, and a group-mark with a word-mark to be inserted in 1401 storage in the next position to the last character typed. The 1401 is released from the interlock and continues operation under stored-program control.
5. The inquiry routine then processes and assembles the data necessary to answer the inquiry, and prints the response.

Console Inquiry with IBM 1401 in Alter Mode with Inquiry Routine

A method of sending an inquiry to the 1401, when an inquiry routine is in 1401 core storage and the 1401 is under operator control, is:

1. Set the manual address switches (1401 console) to the high-order position of the inquiry routine in 1401 storage.
2. Set the mode switch (1401 console) to *ALTER*. Alter light on 1407 comes *ON*.
3. Press the I-address register key-light and the start key (1401 console) to set the address set up by the manual address switches in the I-address register.
4. Set the mode switch (1401 console) to *RUN*. The alter light on the 1407 turns *OFF*. Press the start reset key (1401 console).
5. Press the request enter key on 1407, and the request light comes *ON*. Press the start key (1401 console).
6. The 1401 then starts executing the instruction of the inquiry routine. When the move or load instruction of the routine is reached, the 1401 halts, the enter key-light comes *ON*, request light goes *OFF*, and the system is ready to receive the inquiry.
7. The operator types the inquiry on the 1407. When the message is completed, press the respond key, and a group-mark with a word-mark is inserted in 1401 storage to the right of the inquiry.
8. The 1401 then processes the inquiry. A branch operation can be performed if it is not desired to proceed with the main program after processing the inquiry by the stored program. This operation allows the operator to make the decision to continue processing or take any action necessary.

Restart Procedures

Reader

When a validity or read check error occurs in the card reader, it is necessary to go through the following restart procedure to continue 1401 operation:

1. Open the jogger.
2. Remove the cards in the hopper.
3. Close jogger partially (leave open approximately 45 degrees).
4. Press the non-process run-out key to clear two cards out of the read feed. Cards will not drop from the file-feed magazine.
5. Press the check reset key on the 1402 to reset error indicators.
6. Remove the last three cards from the normal read stacker, correct the card causing the error, and place the cards in the card feed hopper.
7. Replace the other cards in the hopper on top of the three cards.
8. Press the start key to restart the program.

In the case of a read check error, a storage scan operation can be used to determine the position in error.

In the case of a read stop indication without a read check or validity check, cards in the stacker or past the second read brushes have been processed properly. The cards at the throat and read check brushes have not been processed, and must be placed at the front of the file when reading begins again.

Punch

When a punch check error occurs in the punch unit, this procedure can be used to continue 1401 operation:

1. Lift the cards out of the card punch hopper.
2. Press the non-process run-out punch key to clear three cards out of the punch.
3. Press the check reset key on the 1402 to reset the error indicators.
4. Remove the last four cards from the stacker. The first of these cards is the error card. This card can be reconstructed by re-entering the original data into the system and re-processing, or by manual correction of the data in the card. The second card that entered the stacker was punched but it was not checked, therefore, it should be discarded. This card is re-punched on the run-in cycle of the restart operation. The third and fourth cards that enter the stacker are blank.
5. Replace the blank cards in the card punch hopper.

6. Press the start key to restart the program. The last punch cycle (number 2 card in step 4) is repeated and information in the punch storage area is repunched.

When a read check error occurs, a storage scan operation can be used to determine the column in error. If the error occurred on a punch feed read operation, the scan should be started in core-storage position 101 because the scan stops in each position of the read-in area (core-storage locations 001-080). This is the area into which data has been read from the punch feed read station.

In case of a punch stop due to a card feed failure or card jam, and if there is no punch check indication, the punch can be restarted after the punch feed is cleared of cards. The card that was punched on the cycle when the stop occurred, is repunched. This corresponds to card number 2 of step 4.

PUNCH FEED READ

The punch check procedure is:

1. Lift the cards out of the card punch hopper.
2. Press the non-process run-out key to clear three cards out of the punch.
3. Press the check reset key on the 1402 to reset the error indicators.
4. Remove the last four cards from the stacker. The first and second cards should be reconstructed. Cards three and four are correct.
5. Place reconstructed cards one and two and cards three and four and the card file in the card punch hopper.
6. Press START RESET (1401) and the start key, and restart the program (reconstruct internal data if necessary) at the instruction that caused card one to be read by the punch feed read brushes.

The validity check procedure is:

1. Lift the cards out of the card punch hopper.
2. Press the non-process run-out key to clear three cards out of the punch.
3. Press the check reset key on the 1402 to reset the error indicators.
4. Remove the last four cards from the stacker. The first of these cards is correct. The second card must be checked, because it was read and punched but not checked. Card three is the error card. This card should be reconstructed and placed with card four in front of the card file.
5. Place the card file in the card punch hopper.
6. Press START RESET (1401) and the start key, and restart the program at the instruction that caused card three to be read by the punch feed read brushes.

Note: If validity and punch-check errors occur at the same time, use the punch-check restart procedure and check card three for the validity error.

Page 138 — Restart Procedures, Punch — Second column, second paragraph, change line beginning "cleared of cards" to:

cleared of cards. On systems equipped with the processing overlap feature, it is necessary to press the start key twice to resume processing.....

Printer

When a print check error occurs in the printer, the following restart procedure can be used to continue 1401 operation:

WITHOUT PRINT STORAGE

1. Press the print check reset key to reset the error indicators.
2. Turn the mode switch on the processing unit console to STORAGE SCAN.
3. Press the start key. The 1401 stops at the location in storage where the print error occurred and the print check light comes ON.
4. Press the print check reset key to turn off the error indication.
5. Perform a storage scan to determine the position or positions in error if the system stopped due to a B-register error during printing. A position in error can be corrected by entering the correct character.
6. Press the start key a second time to re-scan storage to ensure that not more than one print error or B-register error occurred during the last printed line.
7. Set the core-storage address of the print instruction in the I-address register (see *Storage Address Dial Switches, 1401 Console*).
8. Turn mode switch to RUN.
9. Press the start reset key and then the start key to continue the program.

WITH PRINT STORAGE

1. Press the print check reset key to reset the error indicators.
2. Turn the load switch on the 1401 console to STORAGE SCAN and the mode switch on the auxiliary console to PRINT STORAGE SCAN.
3. Press the start key. The 1401 stops at the location in storage where the print error occurred, and the print check light comes ON.
4. Press the print check reset key to turn off the error indication.
5. Press the start key a second time to re-scan storage to ensure that not more than one print error or B-register error occurred during the last printed line.
6. Because the system stops due to the print error at the print instruction following the operation that was in error, the information to be reprinted must be reconstructed in the print area.
7. If the system stops due to a B-register error during a print transfer, the core-storage position in error can be corrected by entering the correct character after pressing the start reset key (see *Alter Mode, 1401 Console*). The B-register and print error indicators are reset by pressing the process check reset key and the print check reset key.
8. Press the start key a second time to re-scan storage to ensure that not more than one print error or B-register error occurred during the last printed line.
9. Set the core-storage address of the print instruction in the I-address register (see *Storage Address Dial Switches, 1401 Console*).
10. Turn the mode switch to RUN.
11. Press the start reset key and then the start key to continue the program.

Timing

The input, output, and processing abilities of the IBM 1401 Data Processing System are used to greatest advantage, if careful timing consideration is given in the development of each 1401 program. In a card system, computing can usually overlap the input and output operations.

This section includes methods of estimating timing requirements for input-output, calculation, and total job time. Each of these areas is discussed in detail, and timing charts are included where necessary. An

understanding of this material allows the programmer to place efficiently the input-output operation codes. This efficient placement can often save valuable processing time.

The formulas used for calculating the time required to execute an instruction are included. This enables the programmer to figure the time required for the processing of data, and, in combination with the input-output operations, the efficient placement of the various operation codes can be achieved.

Timing Input and Output Operations

Card Reader

The feeding mechanism of the card reader is controlled by a *single tooth clutch* that completes one revolution every 75 ms. If a signal to read is received by the clutch, the feed reads a card as soon as the tooth is at the proper position (*clutch point*). Clutch points are always 75 ms apart.

The read release special feature permits processing during the 21 ms read start time (RST), and makes a total of 31 ms, of the 75-ms cycle, available for processing. The *START READ FEED* instruction is given during the 10 ms normally available for processing. It sends a

signal to engage the clutch for the next read cycle as soon as the current cycle is completed. The *READ A CARD* instruction must then be given during the 21 ms read start time of the next cycle (see *Start Read Feed* operation code).

If processing time exceeds the 10 ms allowed, but is less than 85 ms and read release is not used, card feeding stops for a period of 75 ms (Figure 222). The timing chart shows that two card-read cycles (150 ms) are required to complete such an operation. Of this time, 85 ms are available for processing. If read release is used, an additional 21 ms (read start time from the third card-read cycle) is also available for processing.

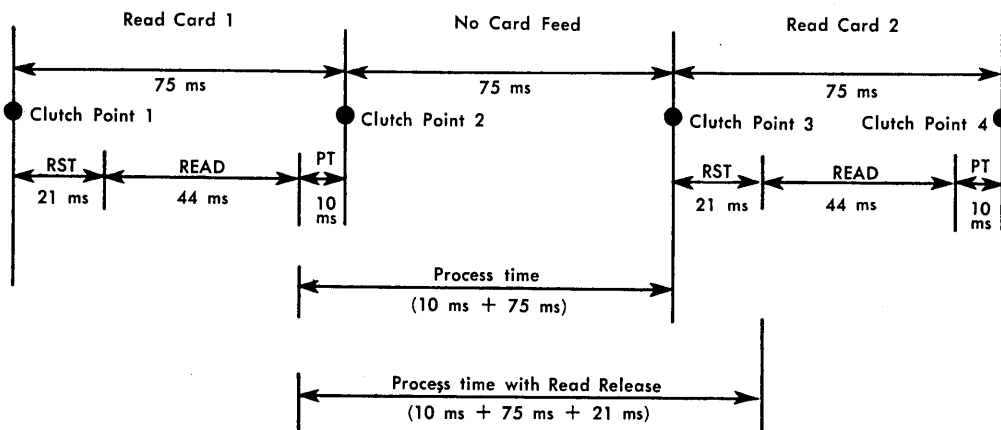

Figure 222. Read Timing Chart (Read Release)

CARDS PER MINUTE	LENGTH OF CYCLE (ms)	PROCESSING TIME (ms)	
		WITHOUT READ RELEASE	WITH READ RELEASE
800	75	10	31
400	150	85	106
266	225	160	181
200	300	235	256

Figure 223. Card Reading Speeds

Note: In this case the START READ FEED instruction can be given any time after clutch point 2 and before clutch point 3.

Figure 223 is a table showing card reading speeds, and the processing time allotted for each.

The early card read feature provides two additional points (clutch points) where the feeding mechanism can engage. When processing between cards exceeds 10 ms, the feed mechanism can engage 50 ms sooner than before. The time between card feeding, is reduced to 100 ms rather than 150 ms. Instead of a 50 per cent reduction in the rated speed (to 400 cpm), there is only a reduction of 25 per cent (to 600 cpm). Figure 224 illustrates these timings and rates in detail.

When early card read is used with read release, additional processing time between the reading of two cards is provided. This is accomplished by using the read start time (21 ms at the beginning of each cycle) as processing time.

The value of both features is realized in those programs with processing routines that exceed the 10 ms allotted for processing during each basic card reading cycle. Although they accomplish separate objectives, they are complementary. Together, they permit the IBM 1401 Data Processing System to operate at speeds closer to capacity, thus effecting shorter over-all job time.

Figures 225 and 226 illustrate cycle timings with the early card read feature. A read release instruction causes the read clutch to engage at the next clutch point, which occurs at 25-millisecond intervals. Therefore, this instruction should not be given more than 23 milliseconds before the time the clutch is to be engaged.

Card Punch

The card punch is operated by a 4-tooth clutch that completes one revolution every 240 ms. Because the clutch has 4 teeth, there are 4 clutch points occurring

TIME BETWEEN CARDS	PROCESSING TIME		CARDS PER MINUTE
	WITHOUT READ RELEASE	WITH READ RELEASE	
75 ms	10	31	800
100 ms	35	56	600
125 ms	60	81	480
150 ms	85	106	400
175 ms	110	131	342
200 ms	135	156	300
225 ms	160	181	266
250 ms	185	206	240

Figure 224. 600 CPM with Early Card Read

at 60-ms intervals in the punch cycle, during which the punch feed can be engaged to operate. As soon as the PUNCH A CARD instruction is interpreted by the program, a signal is sent to the clutch. When the clutch reaches a clutch point, punch start time (PST) begins, followed by punch time and processing time.

The punch release special feature permits processing during the 37 ms punch start time, and increases to 59 ms the total available processing time between successive punch cycles. It initiates punch start time for the next punch cycle as soon as the current punch cycle is completed. See *Start Punch Feed* operation code.

If processing time exceeds 22 ms and START PUNCH FEED is not used, the punch cycle is delayed for 60 ms (Figure 227).

Figure 228 shows card punching speeds and the processing time available with each.

Printer

The IBM 1403 Printer operates at a maximum rated speed of 600 lines per minute. The 100 ms print cycle allows 16 ms of processing time.

The 1401 system is interlocked for the 84 ms print time. The print storage special feature releases all but approximately 2 ms of the entire print cycle, thus making 98 ms available for processing (Figure 229). The print storage area, however, is interlocked for the 84 ms during printing. Form movement for single spacing is overlapped during the last 20 ms of the cycle. If additional forms movement time or additional processing time is required by the application, this time must

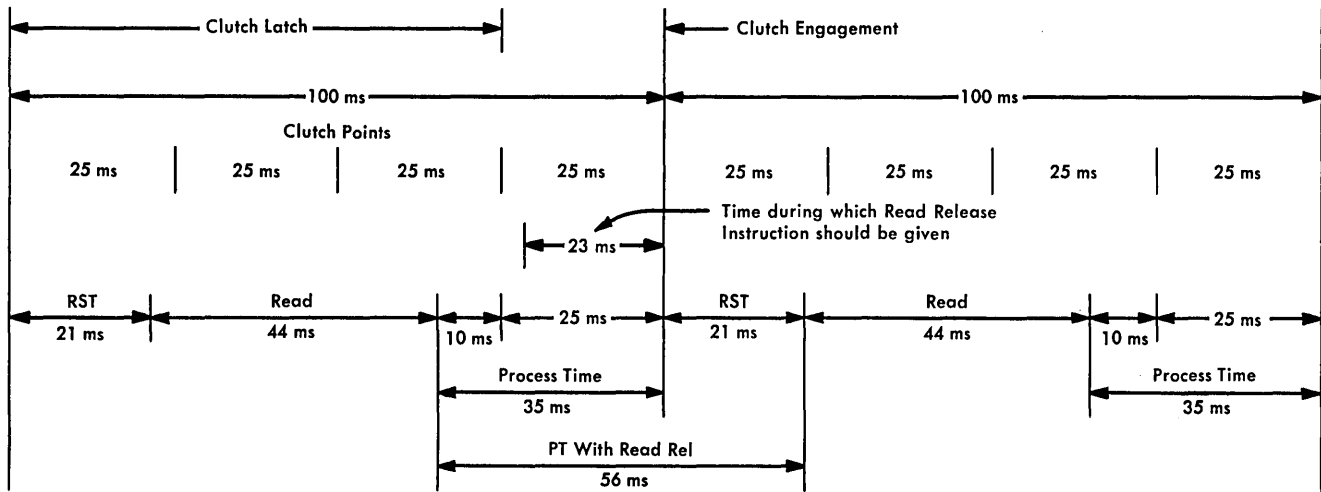

Figure 225. 600 CPM with Early Card Read

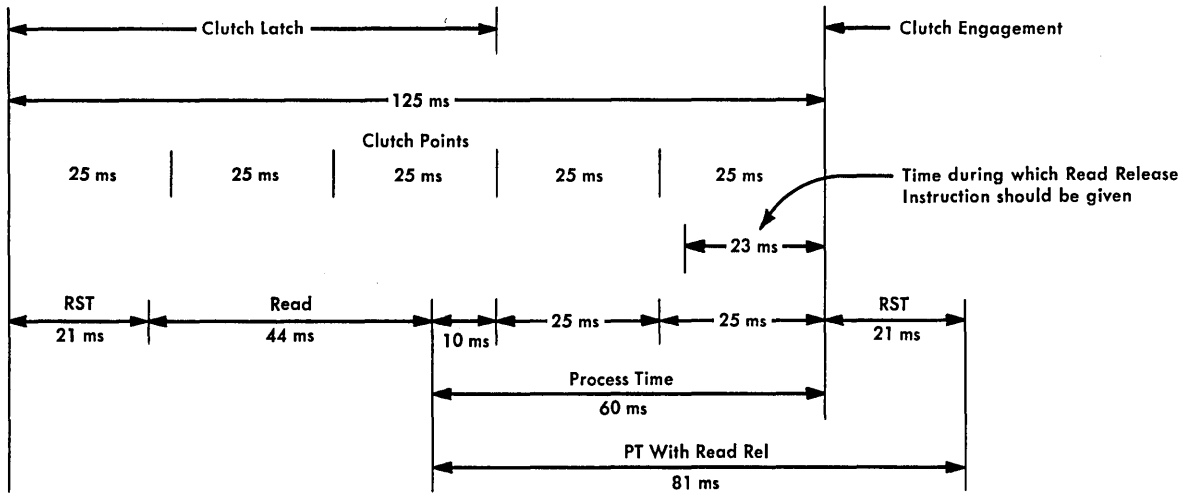

Figure 226. 480 CPM with Early Card Read

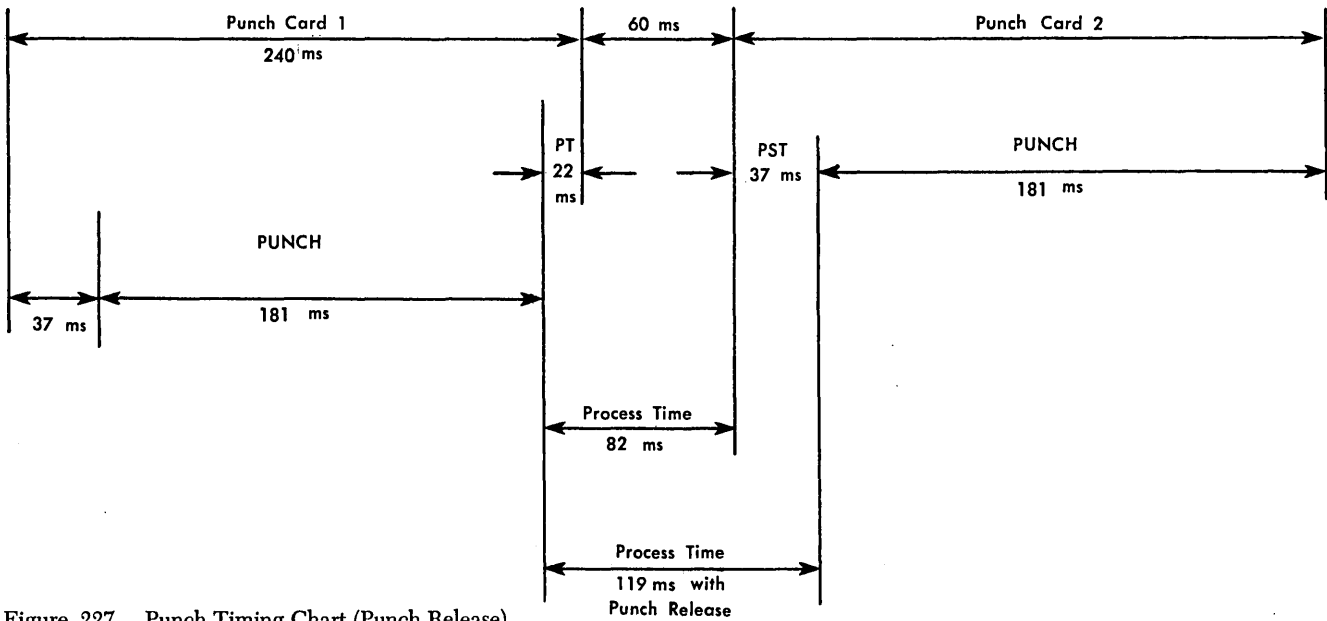

Figure 227. Punch Timing Chart (Punch Release)

CARDS PUNCHED PER MINUTE	LENGTH OF CYCLE (ms)	PROCESSING TIME	
		WITHOUT PUNCH RELEASE	WITH PUNCH RELEASE
250	240	22	59
200	300	82	119
166	360	142	179
143	420	202	239
125	480	262	299

Figure 228. Card Punching Speeds

be added to the 100-ms cycle to determine printing speed.

Figure 230 shows the effective printing speeds under various processing and forms movement considerations with and without the print storage special feature.

Additional forms-skipping time beyond the first 8 lines is calculated by multiplying the number of lines skipped by 2.3 ms.

Some program instructions cause form movement to start immediately. If the printer is printing without using print storage when an immediate forms control instruction is given, or if the carriage is already in motion, the 1401 waits until the previous carriage operation is completed before the immediate skip is executed. If the system is equipped with the print storage special feature, and a CONTROL CARRIAGE instruction is given during the 84-ms print time, the processing unit is interlocked. In this case, skipping takes place when printing and carriage operations are completed, if the program calls for an immediate skip, or follows the next print operation if a delayed skip is indicated.

Immediate skips require 20 ms for the first space, 5 ms for each additional space up to 8, and then 2.3 ms

LINES PRINTED PER MINUTE	LENGTH OF CYCLE (ms)	AVAILABLE PROCESS TIME (ms)		MAXIMUM SPACES SKIPPED WITHIN CYCLE
		WITHOUT PRINT STORAGE	WITH PRINT STORAGE	
600	100	16	98	1
572	105	21	103	2
545	110	26	108	3
522	115	31	113	4
500	120	36	118	5
480	125	41	123	6
462	130	46	128	7
444	135	51	133	8

Figure 230. Effective Printing Speeds

LINES SKIPPED	TIME REQUIRED (ms)
1	20
2	25
3	30
4	35
5	40
6	45
7	50
8	55

Each space over 8 requires an additional 2.3 ms for models B, C, D. Model A requires 5 ms for each space after the first.

Figure 231. Form Movement Time

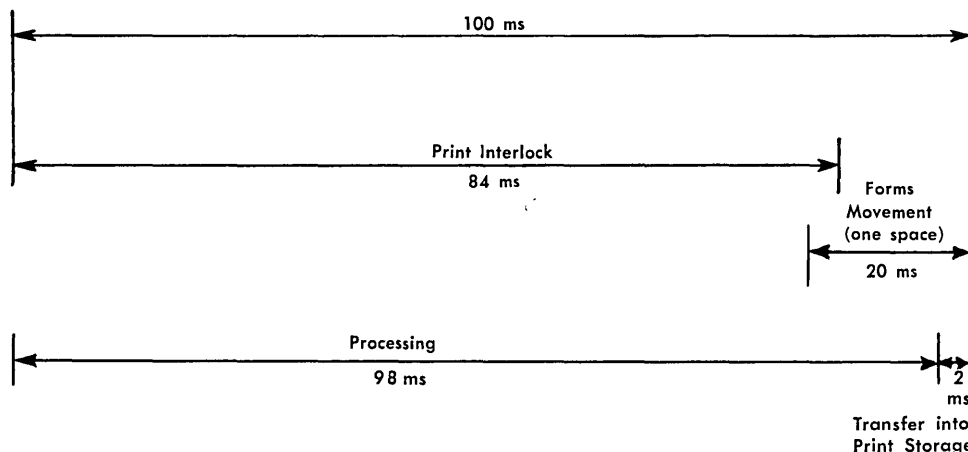

Figure 229. Print Timing Chart (with Print Storage)

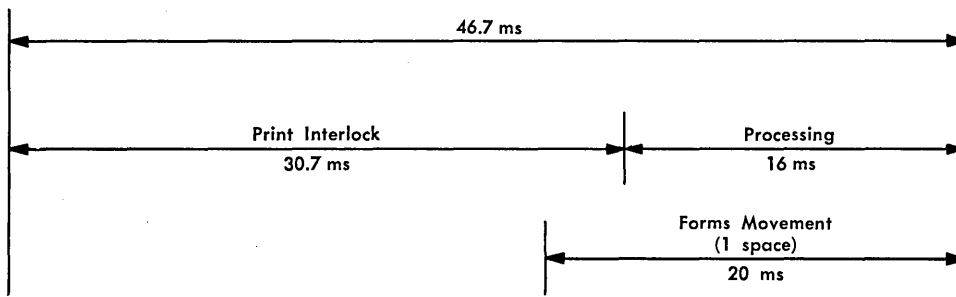

Figure 232. Print Timing Chart (Numerical)

for each space thereafter, except Model A, which requires an additional 5 ms for each space after the first.

Figure 231 shows form movement timing requirements for immediate skip instructions.

With the numerical print feature installed, and the 1403 operating in the numerical mode, the print cycle is 46.7 ms as opposed to the 100 ms cycle in the alpha-merical mode. Because changing from one mode to the other affects neither spacing nor skipping, forms movement time remains 20 ms. Interlock time, however, has been reduced from 84 ms to 30.7 ms (Figure 232). Therefore, the maximum rated speed in the numerical mode is increased to 1285 lines per minute. In either mode the print cycle permits 16 ms of overlapped processing time.

Simultaneous Input-Output Operations

Total job-time improvements are often made through use of combination operation codes, and the read release, punch release, and print storage special features.

The first time a simultaneous operation is performed, the I/O cycle time may not exactly correspond to the cycle shown in the charts; but as the operation is continuously performed, the cycle time will be the same as the time specified in the timing charts.

Combination Print and Read

If reading and printing are to be done as a combined operation (operation code 3) and print storage is not installed, the 1401 can print 400 lines per minute and read 400 cards per minute. The combined cycle takes 150 ms; 18 ms are available for processing.

Figure 233 shows the division of the print cycle, and the functions that are performed.

Note: Read start time extends for four milliseconds beyond print time.

The printer takes priority and operates first. The system is interlocked for the first 84 ms of the cycle. Forms movement can start 80 ms after printing begins and can continue until the end of the cycle. The read operation interlocks the processing unit for 44 ms. The remaining 18 ms are used for processing. A START-READ-FEED instruction should not be given preceding a WRITE AND READ instruction.

Note: If the system is equipped with the print storage and read release special features, the use of a single PRINT A LINE and READ A CARD instruction permits the same speeds as the combination WRITE AND READ instruction — 533 cards and 533 lines per minute. In this case, it becomes more practical to use the single instruction because more processing time is available with the print storage special feature.

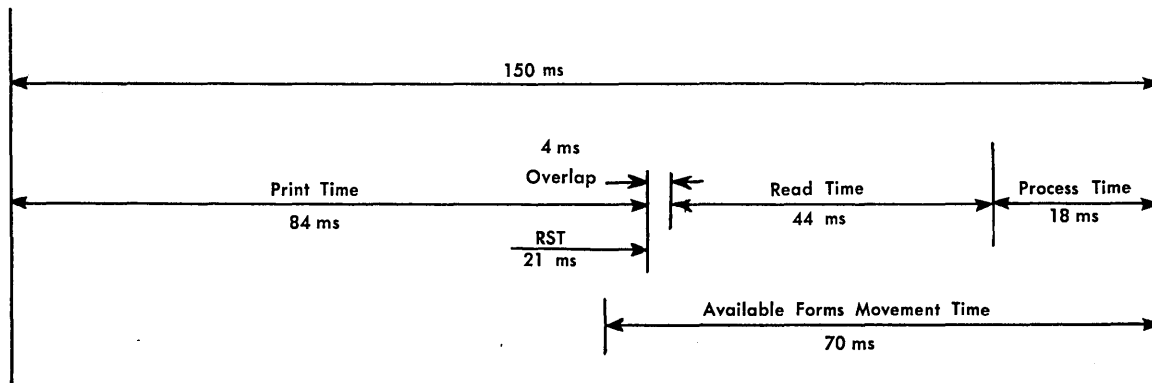

Figure 233. Print and Read Timing Chart

Figure 234 shows the reading and printing operations performed under individual instructions. The 225 ms functional cycle shows the pattern for 2 cards and 2 lines. Repeating this cycle produces the desired speed — 533 cards and 533 lines per minute.

A read instruction starts the operation. The first print instruction is given at point A to initiate print line 1. The line to be printed is transferred to print storage in 2 ms. Eight ms from the first read cycle remain and are available for processing. A read release command must be given during this 8 ms to release the normal 21 ms RST interlock for card-cycle 2. Now there is a total of 29-ms processing time available between the transfer of line 1 to print storage and the READ A CARD instruction. The 1401 is interlocked for 44 ms while card 2 reads into the input area. Because the print storage feature assumes all but 2 ms of the normal printer interlock, the actual read operation is completely overlapped with print time.

An instruction to print given after the read operation would cause the 1401 to wait until the print storage interlock is released. Another READ A CARD instruction would cause the machine to be interlocked at the time print storage is free to receive another WRITE A LINE instruction. Therefore, processing can take place for 25 ms before the next print instruction initiates the printing of the second line. After the 2-ms interlock for the transfer to print storage, a START READ FEED can be given to release the RST interlock for the

third read cycle and to make a total of 79 ms available for processing before the next read operation.

At point B the functional cycle (starting at point A) can begin.

A maximum of three spaces between print lines can be effected during this operation.

Combination Read and Punch

The 1401 can read 250 cards per minute and punch 250 cards per minute if the READ AND PUNCH instruction (operation code 5) is used. The entire read operation is overlapped with card punching during the 240-ms punch cycle. The 22 ms normally available for processing during a punch cycle are also available during this combination operation.

The punch release special feature makes it possible to extend the available processing time to a total of 59 ms. If a START PUNCH FEED instruction is given during the 22 ms following punching, the PST interlock is released.

Figure 235 is a chart showing the relationship between the read and punch operations.

Note: The position of the punch clutch can cause a maximum delay of 60 ms before the first read and punch operation is initiated. However, if processing time is kept within the prescribed time limits, continued use of the READ AND PUNCH instruction permits operation at 250 cards per minute.

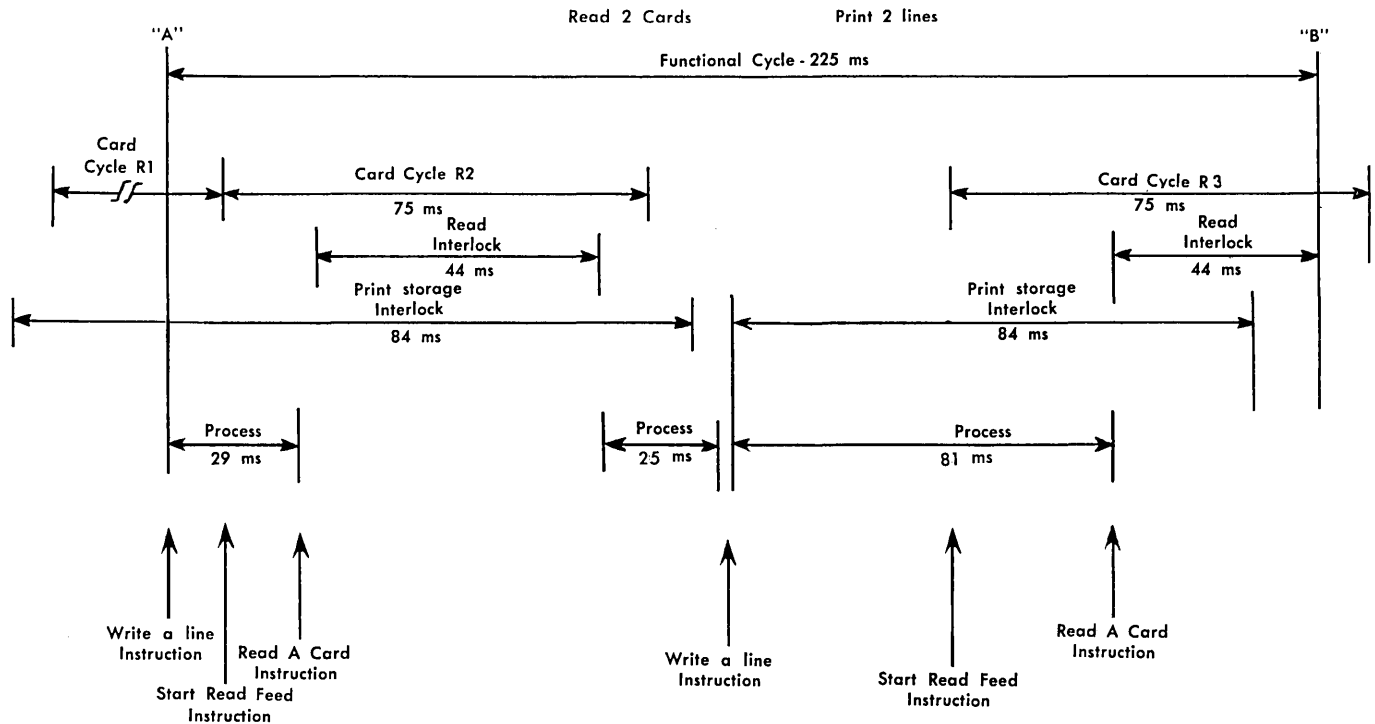

Figure 234. Read and Print Operation with Print Storage and Read Release

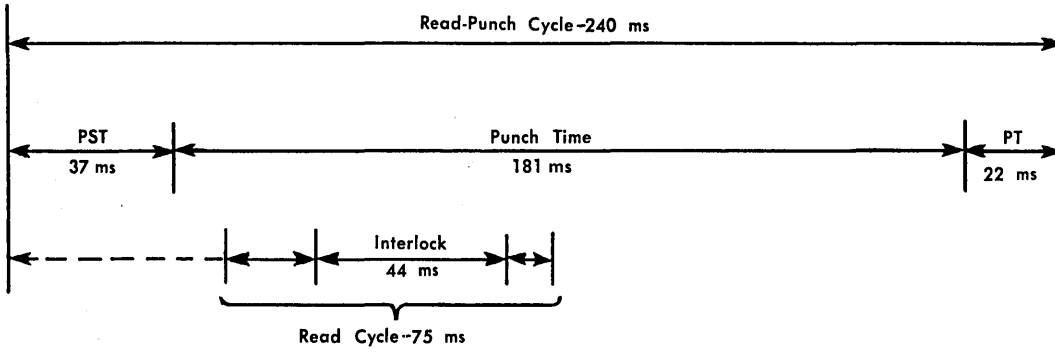
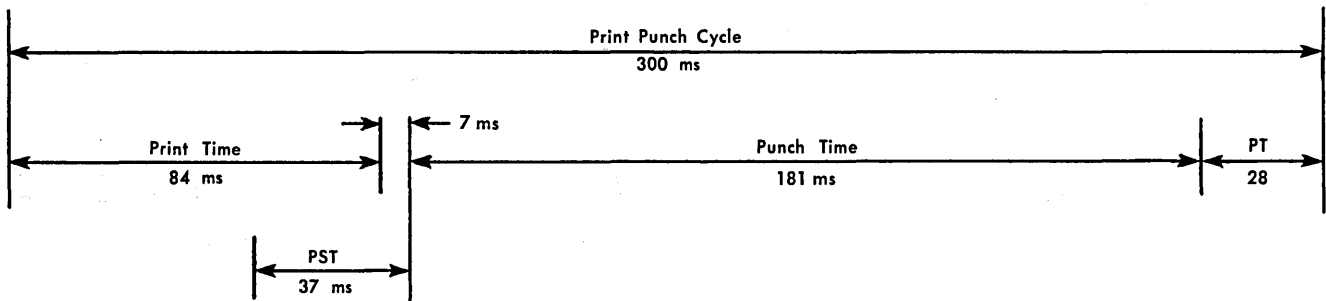

Figure 235. Read and Punch Timing Chart



Note: Punch start time extends for 7 ms beyond Print Time

Figure 236. Print and Punch Timing Chart

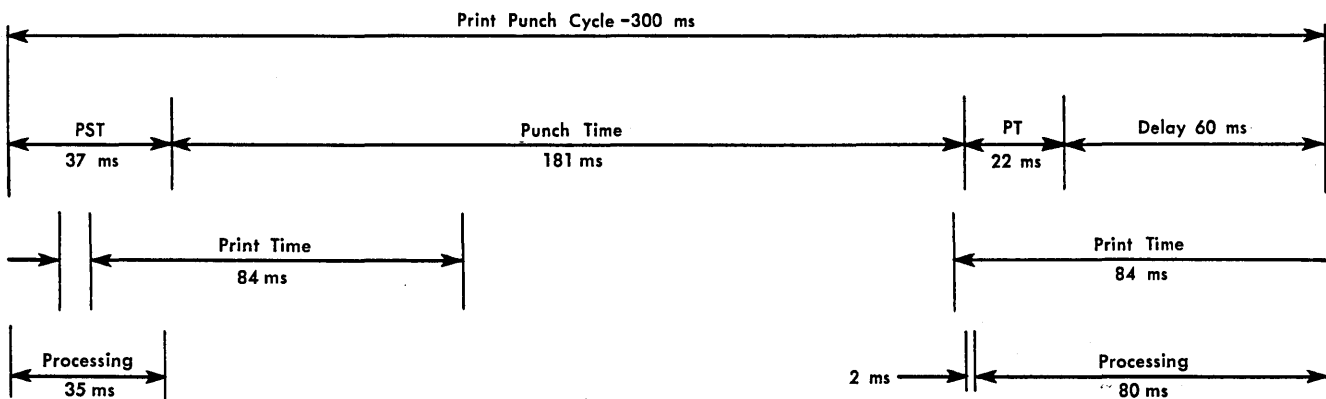

Figure 237. Print and Punch Timing Chart (with Print Storage)

Combination Print and Punch

The 1401 can execute a combination WRITE AND PUNCH instruction (operation code 6) during a 300-ms cycle without using the print storage special feature. Maximum output under these conditions is 200 lines and 200 cards per minute.

Figure 236 shows the relationship between printing and punching with 28 ms processing time available between successive combined operations. The printer always takes priority and operates first. The signal to engage the clutch and initiate the punch operation is automatically given by the machine during the 84-ms print time when operation code 6 is used.

Note: START PUNCH FEED instruction cannot be given preceding a WRITE AND PUNCH combination instruction.

If the print storage special feature is used, print time can be overlapped with punching. This timing is illustrated in Figure 237. Single instructions and the punch release special feature are used to obtain maximum processing time. Output is 400 lines and 200 cards per minute.

Combination Print, Read, and Punch

Cards can be read and punched at the rate of 200 cards per minute and printing can occur at 200 lines per minute if the WRITE, READ, AND PUNCH instruction (operation code 7) is used. The printer takes priority and operates first. Reading time is completely overlapped with punching, and processing time available during the 300-ms cycle is 28 ms. Because the signals to start the reader and the punch are automatic in the combination instruction, START READ FEED and START PUNCH FEED cannot be used. Figure 238 shows the timing for the operation.

Note: The first WRITE, READ AND PUNCH instruction could be extended to a maximum of 360 ms because of clutch wait time. Subsequent successive WRITE, READ, AND PUNCH instructions require 300 ms each.

If the print storage special feature is installed in the system, the input-output rates can be increased to 250 cards and 250 lines per minute and the cycle time can be reduced to 240 ms. The punch release special feature makes it possible to increase processing time when print storage is available. Figure 239 is a card and printer summary timing chart.

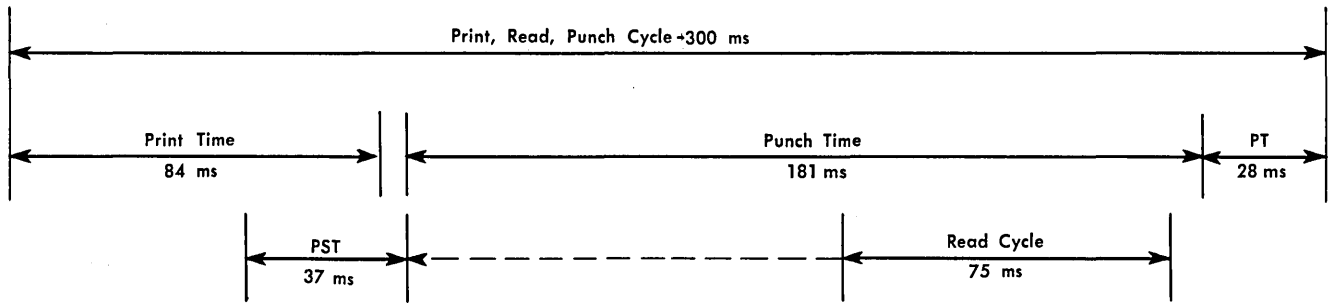

Note: Punch start time extends for 7 ms beyond Print Time

Figure 238. Print, Read, and Punch Timing Chart

OP CODE	OPERATION	CYCLE	RATE	PROCESSING TIME AVAILABLE	
				WITHOUT RELEASE INSTRUCTION	WITH RELEASE INSTRUCTION
1	Read	75 ms 150 ms 225 ms	800 cpm 400 cpm 266 cpm	10 ms 85 ms 160 ms	31 ms 106 ms 181 ms
2	Print — Without print storage				
	Single space	100 ms	600 lpm	16 ms	
	Double space	105 ms	572 lpm	21 ms	
	Triple space	110 ms	545 lpm	26 ms	
	Print — With print storage				
	Single space	100 ms	600 lpm	98 ms	
Double space	105 ms	572 lpm	103 ms		
Triple space	110 ms	545 lpm	108 ms		
1 and 2	Print & Read With print storage	112.5 ms	533 cpm	8 ms	
3	Print & Read Without print storage	150 ms	400 cpm	18 ms	
4	Punch	240 ms	250 cpm	22 ms	59 ms
		300 ms	200 cpm	82 ms	119 ms
		360 ms	166 cpm	142 ms	179 ms
5	Read & Punch	240 ms	250 cpm/rd 250 cpm/pu	28 ms	59 ms
		300 ms	200 cpm/rd 200 cpm/pu	22 ms	59 ms
6	Print & Punch Without print storage	300 ms	200 lpm/pr 200 cpm/rd	28 ms	
	With print storage	240 ms	250 lpm/pr 250 cpm/rd	20 ms	57 ms
7	Print, Read, & Punch Without print storage	300 ms	200 lpm/pr 200 cpm/rd 200 cpm/pu	28 ms	
	With print storage	240 ms	250 lpm/pr 250 cpm/rd	20 ms	57 ms

Figure 239. Card and Printer Summary Timing Chart

Processing Time

To make realistic timing estimates for processing, it is necessary to consider the individual instructions used and the number of data characters involved in each operation. One approach that can be used is:

1. Develop a general block diagram for the problem to be solved.
2. Define the operation performed in each block.
3. Determine the number of and type of instructions required to accomplish the operations in the block. The length of the data fields should be known.
4. Using the formulas listed in *System Timings* (Figure

240), calculate the time required to perform the operations. The timings shown are expressed in milliseconds.

5. Four charts have been included that give approximate timings for multiplication and division operations. Two of the charts (Figure 241 and 243) give the time required when the multiply and divide special features are included in the system. The other charts (Figure 242 and 244) give the timings for multiply and divide, based upon the subroutines written in actual language in the section, *Multiplication and Division Subroutines*.

SYSTEM TIMINGS			SYSTEM TIMINGS		
<p>Key to abbreviations used in formulas</p> <p>L_A = Length of the A-field</p> <p>L_B = Length of the B-field</p> <p>L_O = Length of Multiplicand field</p> <p>L_I = Length of Instruction</p> <p>L_X = Length of Multiplier field</p> <p>L_Q = Length of Quotient field</p> <p>L_D = Length of Divisor field</p> <p>L_S = Number of significant digits in Divisor (Excludes high-order 0's and blanks)</p> <p>L_W = Length of A- or B-field, whichever is shorter</p> <p>L_X = Number of characters to be cleared</p> <p>L_Y = Number of characters back to right-most "0" in control field</p> <p>L_Z = Number of 0's inserted in a field</p> <p>I/O = Timing for Input or Output cycle</p> <p>F_m = Forms movement times. Allow 20 ms for first space, plus 5 ms for each additional space</p> <p>T_m = Tape movement times</p> <p>Σ = Number of fields included in an operation</p>			OPERATION	OP CODE	FORMULA
			Punch a Card	4	.0115 ($L_I + 1$) + I/O
			Read a Card	1	.0115 ($L_I + 1$) + I/O
			Read and Punch	5	.0115 ($L_I + 1$) + I/O
			Select Stacker	K	.0115 ($L_I + 1$)
			Set Word Mark	9	.0115 ($L_I + 3$)
			Start Punch Feed*	9	.0115 ($L_I + 1$)
			Start Read Feed*	8	.0115 ($L_I + 1$)
			Store A-address Register*	Q	.0115 ($L_I + 5$)
			Store B-address Register*	H	.0115 ($L_I + 4$)
			Subtract (no recomplement)	S	.0115 ($L_I + 3 + L_A + L_B$)
			Subtract (recomplement)	S	.0115 ($L_I + 3 + L_A + 4 L_B$)
			Write a Line	2	.0115 ($L_I + 1$) + I/O
			Write and Punch	6	.0115 ($L_I + 1$) + I/O
			Write and Read	3	.0115 ($L_I + 1$) + I/O
			Write, Read and Punch	7	.0115 ($L_I + 1$) + I/O
			Zero and Add	?	.0115 ($L_I + 1 + L_A + L_B$)
			Zero and Subtract	!	.0115 ($L_I + 1 + L_A + L_B$)
			TAPE OPERATIONS		
OPERATION	OP CODE	FORMULA	<p>T_m - Tape movement can be determined from the following:</p> <p>1 = Number of Characters</p> <p>C = Character Rate</p> <p>729 II at 200 cpi = .067 ms</p> <p>at 556 cpi = .024 ms</p> <p>729 IV at 200 cpi = .044 ms</p> <p>at 556 cpi = .016 ms</p> <p>7330 at 200 cpi = .139 ms</p> <p>at 556 cpi = .050 ms</p> <p>729 Model II, Read 10.7 + CN ms = TAU interlocked</p> <p>10.5 + CN ms = Processing interlocked</p> <p>Write 11.7 + CN ms = TAU interlocked</p> <p>7.5 + CN ms = Processing interlocked</p> <p>729 Model IV, Read 6.8 + CN ms = TAU interlocked</p> <p>6.7 + CN ms = Processing interlocked</p> <p>Write 7.8 + CN ms = TAU interlocked</p> <p>5 + CN ms = Processing interlocked</p> <p>7330 Read 20.5 + CN ms = TAU interlocked</p> <p>7.7 + CN ms = Processing interlocked</p> <p>Write 20.3 + CN ms = TAU interlocked</p> <p>5 + CN ms = Processing interlocked</p> <p>Rewind</p> <p>729 Model II = 1.2 minutes/reel</p> <p>729 Model IV = .9 minutes/reel</p> <p>7330 (High Speed) = 2.2 minutes/reel</p> <p>Skip and Blank Tape (add to subsequent write time)</p> <p>729 Model II = 40.5 ms</p> <p>729 Model IV = 27 ms</p> <p>7330 = 103 ms</p> <p>Backspace (after Read) Backspace (after Write)</p> <p>729 Model II = 46 + CN ms 729 Model II = 52 + CN ms</p> <p>729 Model IV = 33 + CN ms 729 Model IV = 37 + CN ms</p> <p>7330 = 428 + CN ms 7330 = 435 + CN ms</p>		
Add (no recomplement)	A	.0115 ($L_I + 3 + L_A + L_B$)			
Add (recomplement)	A	.0115 ($L_I + 3 + L_A + 4 L_B$)			
Branch	B	.0115 ($L_I + 1$)			
Branch if Bit Equal*	W	.0115 ($L_I + 2$)			
Branch if Character Equal	B	.0115 ($L_I + 2$)			
Branch if Indicator On	B	.0115 ($L_I + 1$)			
Branch if Word Mark and/or Zone	V	.0115 ($L_I + 2$)			
Clear Storage	/	.0115 ($L_I + 1 + L_X$)			
Clear Word Mark	□	.0115 ($L_I + 3$)			
Compare	C	.0115 ($L_I + 1 + L_A + L_B$)			
Control Carriage	F	.0115 ($L_I + 1$) + F_m			
Control Unit	U	.0115 ($L_I + 1$) + T_m			
Divide (aver.)*	%	.0115 ($L_I + 2 + 7 L_X L_Q + 8 L_Q$)			
Halt	*	.0115 ($L_I + 1$)			
Load Characters to A Word Mark	L	.0115 ($L_I + 1 + 2 L_A$)			
Modify Address*	#	.0115 ($L_I + 9$)			
Move Characters to A or B Word Mark	M	.0115 ($L_I + 1 + 2 L_W$)			
Move Characters and Edit	E	.0115 ($L_I + 1 + L_A + L_B + L_X$)			
Move Characters to Record or Word Mark*	P	.0115 ($L_I + 1 + 2 L_A$)			
Move Characters and Suppress Zeros	Z	.0115 ($L_I + 1 + 3 L_A$)			
Move and Insert Zeros*	X	.0115 ($L_I + 1 + 2 \Sigma L_A + \Sigma L_Z$)			
Move Numeric	D	.0115 ($L_I + 3$)			
Move Zone	Y	.0115 ($L_I + 3$)			
Multiply (aver.)*	@	.0115 ($L_I + 3 + 2 L_O + 5 L_C L_X + 7 L_X$)			
No Operation	N	.0115 ($L_I + 1$)			

Figure 240. Systems Timings

1401 DIVIDE TIMES WITH SPECIAL FEATURE											
No. of Pos. in Quotient →		1	2	3	4	5	6	7	8	9	10
No. of Pos. in Divisor ↓	1	.276	.449	.621	.794	.966	1.139	1.311	1.484	1.656	1.829
	2	.357	.610	.863	1.116	1.369	1.622	1.875	2.128	2.381	2.634
	3	.438	.771	1.104	1.437	1.770	2.103	2.436	2.769	3.102	3.435
	4	.518	.932	1.346	1.760	2.174	2.588	3.002	3.416	3.830	4.244
	5	.598	1.093	1.588	2.083	2.578	3.073	3.568	4.063	4.558	5.053
	6	.679	1.254	1.829	2.404	2.979	3.554	4.129	4.704	5.279	5.854
	7	.759	1.415	2.071	2.727	3.383	4.039	4.695	5.351	6.007	6.663
	8	.840	1.576	2.312	3.048	3.784	4.520	5.256	5.992	6.728	7.464
	9	.920	1.737	2.553	3.370	4.186	5.003	5.819	6.636	7.452	8.269
	10	1.001	1.898	2.795	3.692	4.589	5.486	6.383	7.280	8.177	9.074

Figure 241. IBM 1401 Divide Times (with Special Feature)

1401 DIVIDE TIMES BASED ON DIVIDE SUBROUTINE											
No. of Pos. in Quotient →		1	2	3	4	5	6	7	8	9	10
No. of Pos. in Divisor ↓	1	11.815	15.468	19.113	22.762	26.411	30.060	33.709	37.358	41.007	44.656
	2	11.446	15.267	19.088	22.909	26.730	30.551	34.372	38.193	42.014	45.835
	3	11.078	15.072	19.066	23.060	27.054	31.048	35.042	39.036	43.030	47.024
	4	10.710	14.876	19.042	23.208	27.374	31.540	35.706	39.872	44.038	48.204
	5	10.342	14.681	19.020	23.359	27.698	32.037	36.376	40.715	45.054	49.393
	6	9.974	14.485	18.996	23.507	28.018	32.529	37.040	41.551	46.062	50.573
	7	9.606	14.290	18.974	23.658	28.342	33.026	37.710	42.394	47.078	51.762
	8	9.238	14.094	18.950	23.806	28.662	33.518	38.374	43.230	48.086	52.942
	9	8.870	13.899	18.928	23.957	28.986	34.015	39.044	44.073	49.102	54.131
	10	8.502	13.703	18.904	24.105	29.306	34.507	39.708	44.909	50.110	55.311

(Add 1 ms to times shown above if signing of quotient is required.)

Figure 242. IBM 1401 Divide Times (Based on Divide Subroutine)

1401 MULTIPLY TIMES WITH SPECIAL FEATURE												
No. Pos. Multiplicand →		1	2	3	4	5	6	7	8	9	10	11
Number Positions Multiplier ↓	1	.276	.347	.418	.489	.560	.631	.702	.773	.844	.915	.986
	2	.414	.552	.690	.828	.966	1.104	1.242	1.380	1.518	1.656	1.794
	3	.552	.748	.944	1.140	1.336	1.532	1.728	1.924	2.120	2.316	2.512
	4	.690	.943	1.196	1.449	1.703	1.956	2.209	2.462	2.715	2.968	3.221
	5	.828	1.139	1.450	1.761	2.072	2.383	2.694	3.005	3.316	3.627	3.938
	6	.966	1.334	1.702	2.070	2.438	2.806	3.174	3.542	3.910	4.278	4.646
	7	1.104	1.530	1.956	2.382	2.808	3.234	3.660	4.086	4.512	4.938	5.364
	8	1.242	1.725	2.208	2.691	3.174	3.657	4.140	4.623	5.106	5.589	6.072
	9	1.380	1.921	2.462	3.003	3.544	4.085	4.626	5.167	5.708	6.249	6.790
	10	1.518	2.116	2.714	3.312	3.910	4.508	5.106	5.704	6.302	6.900	7.498

Figure 243. IBM 1401 Multiply Times (with Special Feature)

1401 MULTIPLY TIMES BASED ON MULTIPLY SUBROUTINE												
No. Pos. Multiplicand	→	1	2	3	4	5	6	7	8	9	10	11
Number Positions Multiplier	1	3.51	3.63	3.74	3.86	3.97	4.08	4.20	4.32	4.43	4.55	4.67
Value of each	2	7.10	7.33	7.56	7.79	8.02	8.25	8.48	8.71	8.94	9.17	9.40
Multiplier Digit	3	10.74	11.08	11.43	11.77	12.12	12.46	12.81	13.15	13.50	13.84	14.19
assumed to be an	4	14.42	14.88	15.34	15.80	16.26	16.72	17.18	17.64	18.10	18.56	19.02
average of "5"	5	18.15	18.73	19.30	19.88	20.45	21.03	21.60	22.18	22.75	23.33	23.90
	6	21.93	22.62	23.31	24.00	24.69	25.38	26.07	26.76	27.45	28.14	28.83
	7	25.76	26.57	27.37	28.18	28.98	29.79	30.59	31.40	32.20	33.01	33.81
	8	29.63	30.55	31.47	32.39	33.31	34.23	35.15	36.07	36.99	37.91	38.83
	9	33.54	34.58	35.61	36.65	37.68	38.72	39.75	40.79	41.82	42.86	43.89

(Add 1 ms to times shown above if it is required to 'sign' the product.)

Figure 244. IBM 1401 Multiply Times (Based on Multiply Subroutine)

Tape Processing Time

All tape units in a 1401 system are under the control of a tape adapter unit (TAU). TAU can control the operations of only one tape unit at a time. If one tape unit is busy, no other tape unit can be used until all operations on the busy one have been completed. The execute time of 1401 tape instruction varies according to the type and model tape units used in the system (Figure 240).

C is the character rate in milliseconds based on the setting of the tape density switch.

N is the number of characters in the record.

CN is record time (number of characters in the record, times the character rate).

Start time is the time necessary for the tape unit to accelerate to operating speed.

Stop time is the time necessary for the tape unit to decelerate and stop.

Record check time is the time it takes to read or write the check character. This time is based on the read-write head gap (the distance that separates the

read and write heads) and the time it takes a single character written on tape to travel from the write head to the read head.

IBM 729 II Tape Timings

During a 729 II *read* operation, the tape adapter unit is interlocked for $10.7 + CN$ ms (Figure 245). This includes:

- 10.5 ms – start time
- .2 ms – record check time for high-density tape (.6 for low-density tape)
- CN ms – record time

During the same read operation, the processing unit is interlocked for $10.5 + CN$ ms. This includes:

- 10.5 ms – start time
- CN ms – record time

Therefore, in a tape read operation, processing can take place during the 2.1 ms stop time. A tape transmission error condition can be recognized .2 ms after the processing interlock is released. If the tape transmission error test instruction is given during this .2 ms period, the processing unit is interlocked until the error indicator can be interrogated.

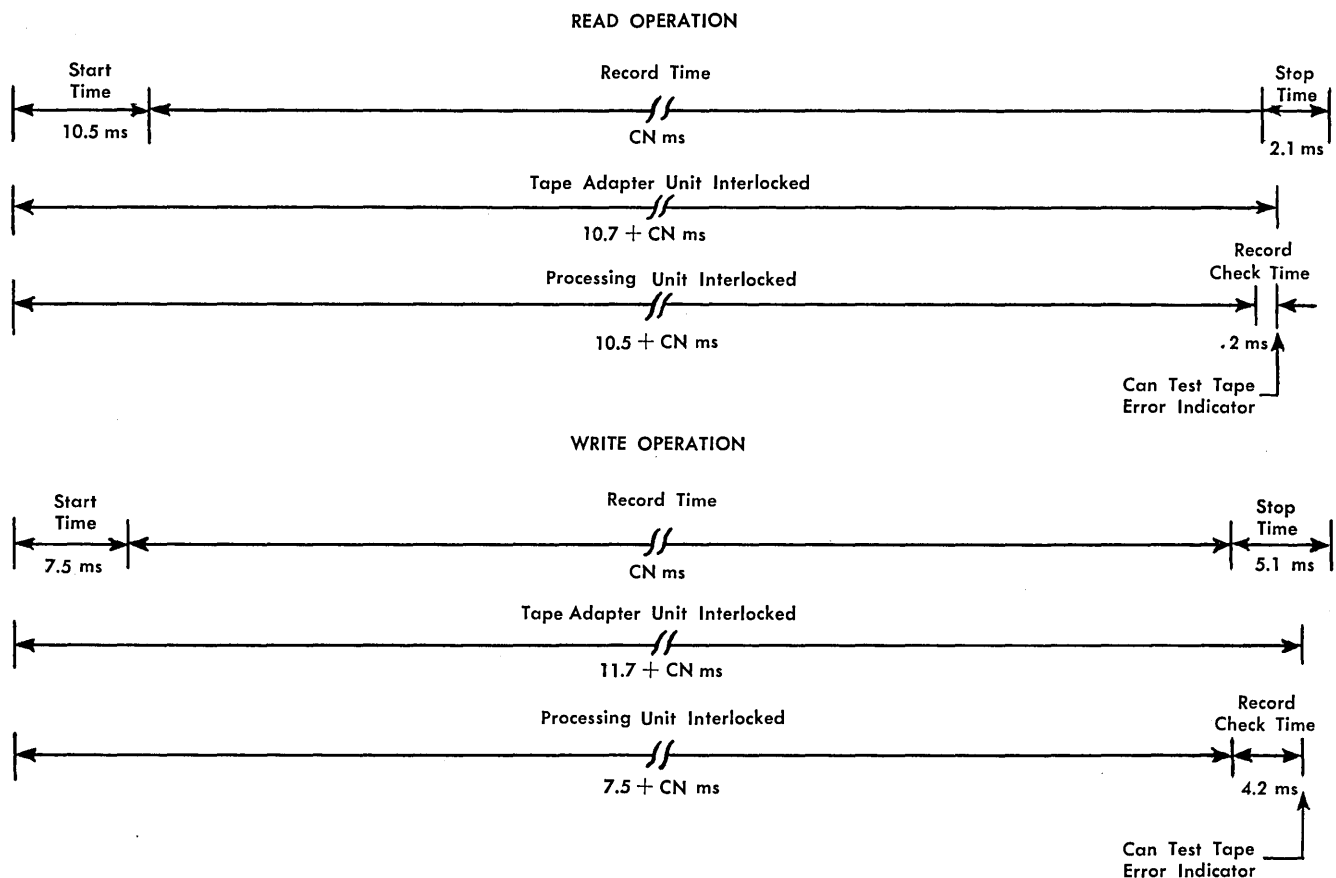

Figure 245. IBM 729, Model II, Read-Write Tape Timing

During a 729 II tape *write* operation, the tape adapter unit is interlocked for $11.7 + CN$ ms (Figure 245). This includes:

- 7.5 ms – start time
- 4.2 ms – record check time for high-density tape (4.6 for low-density tape)
- CN ms – record time

During the same write operation, the processing unit is interlocked for $7.5 + CN$ ms. This includes:

- 7.5 ms – start time
- CN ms – record time

Therefore, in a tape write operation, processing can take place during the 5.1 ms stop time. A tape transmission error condition can be recognized 4.2 ms after the processing interlock is released. If the tape transmission error test instruction is given during this 4.2 ms period, the processing unit is interlocked until the error indicator can be interrogated. The difference between the .2 ms record check time of reading and the 4.2 ms record check time of writing is due to the read-write head gap time (4.0 ms).

For job timing estimates of tape read-write operations, the nominal formula $10.8 + CN$ ms can be used.

IBM 729 IV Tape Timings

During a 729 IV *read* operation, the tape adapter unit is interlocked for $6.8 + CN$ ms (Figure 246). This includes:

- 6.7 ms – start time
- .1 ms – record check time for high-density tape (.4 for low-density tape)
- CN ms – record time

During the same read operation, the processing unit is interlocked for $6.7 + CN$ ms. This includes:

- 6.7 ms – start time
- CN ms – record time

Therefore, in a tape read operation, processing can take place during the 2.1 ms stop time. A tape transmission error condition can be recognized .1 ms after the processing interlock is released. If the tape transmission error test instruction is given during this .1 ms period, the processing unit is interlocked until the error indicator can be tested.

During a 729 IV tape *write* operation, the tape adapter unit is interlocked for $7.8 + CN$ ms (Figure 246).

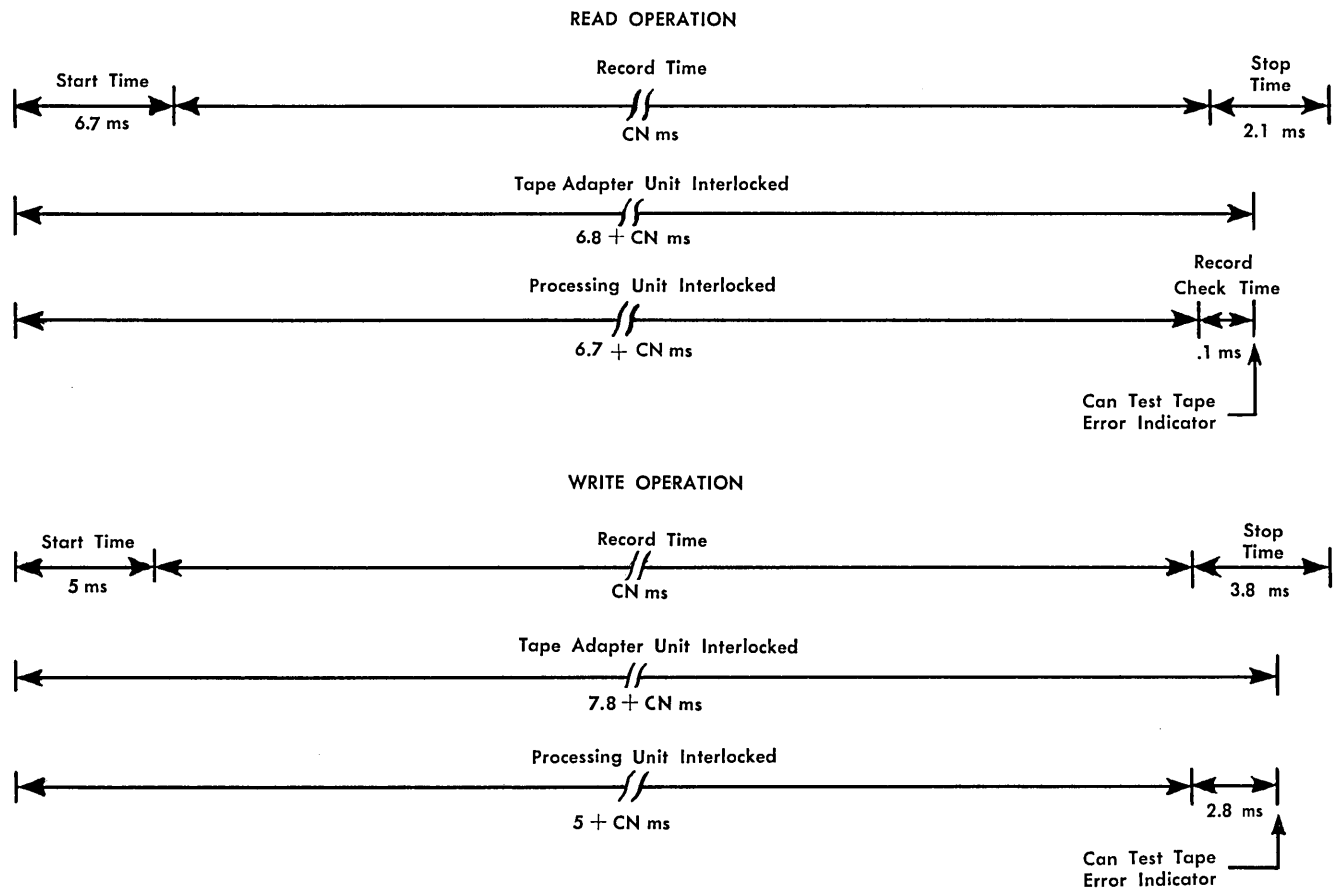

Figure 246. IBM 729, Model IV, Read-Write Tape Timing

This includes:

- 5 ms – start time
- 2.8 ms – record check time for high-density tape (3.0 ms for low-density tape)
- CN ms – record time

During the same write operation, the processing unit is interlocked for $5 + CN$ ms. This includes:

- 5 ms – start time
- CN ms – record time

Therefore, in a tape write operation, processing can take place during the 3.8 ms stop time. A tape transmission error condition can be recognized 2.8 ms after the processing interlock is released. If the tape transmission error test instruction is given during this 2.8 ms period, the processing unit is interlocked until the error indicator can be interrogated. The difference between the .1 ms record check time of reading and the 2.8 record check time of writing is due to the read-write head gap time (2.7 ms).

For job timing estimates of tape read-write operations, the nominal formula $7.3 + CN$ ms can be used.

IBM 7330 Tape Timings

During a 7330 tape read operation, the tape adapter unit is interlocked for $20.5 + CN$ ms (Figure 247). This includes:

- 7.6 ms – start time
- 12.5 ms – stop time
- .4 ms – record check time for high-density tape (1.0 ms for low-density tape)
- CN ms – record time

During the same read operation, the processing unit is interlocked for $7.7 + CN$ ms. This includes:

- 7.6 ms – start time
- .4 ms – record check time for high-density tape (1.0 ms for low-density tape)
- CN ms – record time

Therefore, in a tape read operation, processing can take place during 12.8 ms of stop time and record-check time. A tape transmission error condition can be recognized .3 ms after the processing interlock is released.

During a 7330 tape write operation, the tape adapter unit is interlocked for $20.3 + CN$ ms (Figure 248). This includes:

- 5.0 ms – start time
- 6.6 ms – stop time
- 8.7 ms – record check time for high-density tape (9.3 ms for low-density tape)
- CN ms – record time

During the same write operation, the processing unit is interlocked for $5 + CN$ ms. This includes:

- 5.0 ms – start time
- CN ms – record time

Therefore, in a tape write operation, processing can take place during the 15.3 ms stop time. A tape transmission error condition can be recognized 8.7 ms after the processing interlock is released. If the tape transmission test instruction is given during this 8.7 ms period, the processing unit is interlocked until the error indicator can be interrogated. The difference between the .4 ms record check time of reading and the 8.7 ms record check time of writing is due to the read-write head gap time (8.3 ms).

For job timing estimates of read operations in either high- or low-density, use the formula $20.1 + C(N + 7)$ ms, where the factor C (7) is the record check time.

For job timing estimates of write operations in either high- or low-density, use the formula $19.9 + C(N + 7)$ ms, where the factor C (7) is the record check time, and 8.3 ms of the 19.9 ms is the read-write head gap time.

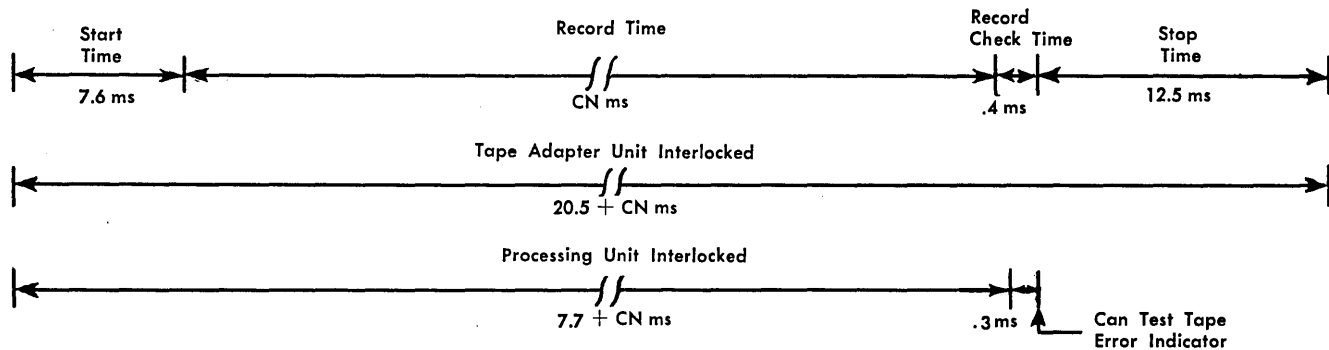

Figure 247. IBM 7330 Read Tape Timing

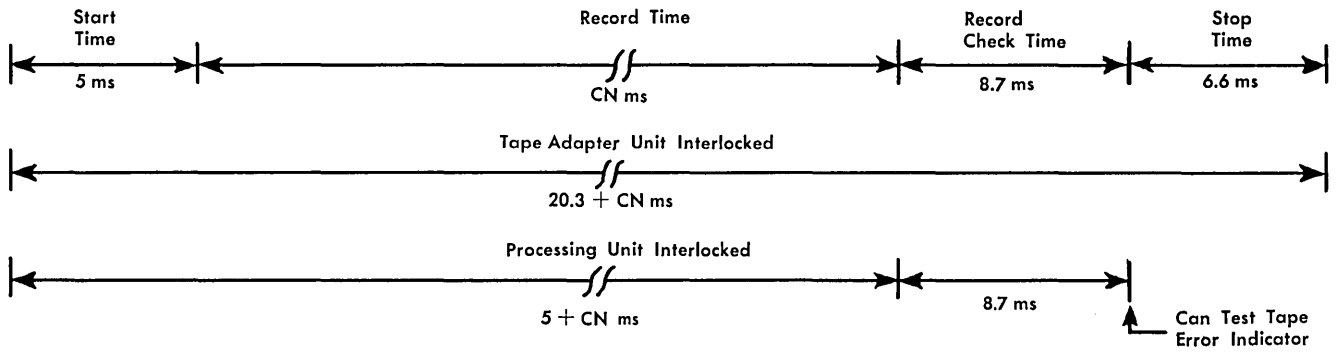

Figure 248. IBM 7330 Write Tape Timing

Processing Overlap Timing

The addition of the processing overlap special feature can provide great reductions in over-all job times. To use the overlap feature to the greatest advantage, careful timing consideration should be given in the development of each 1401 program and to the operations that are to be overlapped.

Charts on the increase in processing time through the use of the overlap feature are included to aid in efficient placement of overlapped instruction (Figure 249).

A careful analysis of these charts allows the programmer to place efficiently the input-output operations

codes. This efficient placing of I/O operations can reduce over-all job time by the overlapping of I/O operations and processing (Figure 250).

Magnetic Tape Operations

The factors that are added to the overlapped tape start and stop times have been derived by subtracting one storage cycle from the character rate of the tape unit and compensating for tape unit timing. The character rate and tape timings for each tape unit can be found in the section on *Processing Time*.

OPERATION	1402 CYCLE ms	PROCESSING TIME AVAILABLE		
		STANDARD ms	WITH READ RELEASE ms	WITH PROCESSING OVERLAP ms
Read	75	10	31	63
Read Column Binary	75	10	31	52
Punch	240	22	59	224
Punch Column Binary	240	22	59	212
Read and Punch	240	22	56	213
Read-Punch Feed	240	22	56	209

Figure 249. Summary of Overlapped Card Operation Timing

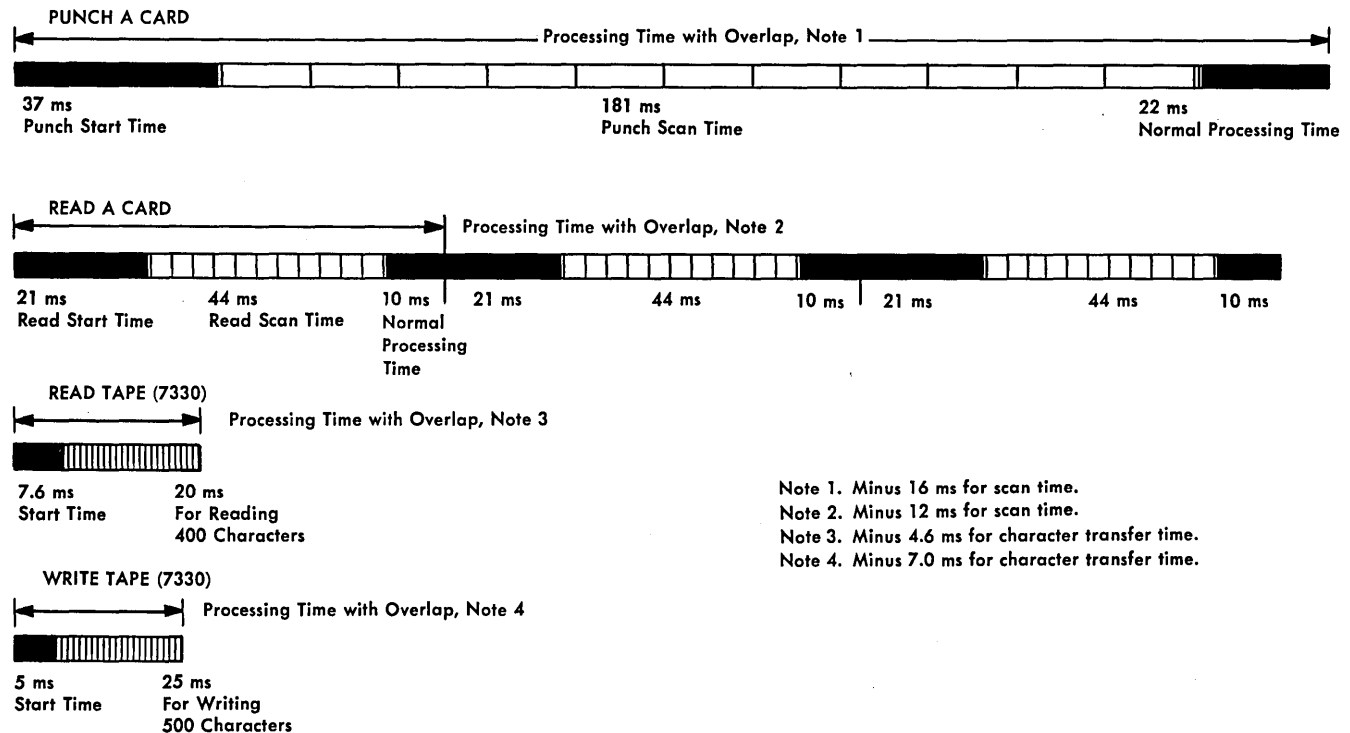

Figure 250. Comparison of Standard and Overlapped Processing Times

Figure 251 can be used to help in determining the amount of processing time available for overlapped tape read and write operations.

Reading a thousand-character tape record written in low-density on an IBM 729 II tape unit, without the processing overlap feature, interlocks the 1401 processing unit for:

$$\begin{aligned}
 &10.5 + \text{CN} \\
 &10.5 + (.067 \times 1000) \\
 &10.5 + 67 \\
 &77.5 \text{ ms}
 \end{aligned}$$

Using the processing overlap feature, 66.1 ms are available for processing during tape-movement time.

$$\begin{aligned}
 &11.1 + (.055 \times 1000) \\
 &11.1 + 55 \\
 &66.1 \text{ ms}
 \end{aligned}$$

This means that the IBM 1401 Processing Unit is interlocked for only 12 ms. Therefore, the resulting effect is that the processing unit is interlocked only for the

time it takes to transfer characters from magnetic tape to core-storage.

The time used for tape movement (T_M) remains the same for an overlap or non-overlap operation. Tape movement time for the same read operation regardless of processing overlap is:

$$\begin{aligned}
 T_M &= 11.1 + \text{CN} \\
 T_M &= 11.1 + (.067 \times 1000) \\
 T_M &= 11.1 + 67 \\
 T_M &= 78.1 \text{ ms}
 \end{aligned}$$

With the processing overlap feature 66.1 ms are available for processing during the reading of a thousand-character tape record. If the 1401 system does not have the processing overlap feature, only 0.6 ms of the total tape-movement time are available for processing. Thus, the processing overlap feature results in a saving of 65.5 ms of what would normally be processing-unit interlock time.

TAPE UNIT	TAPE DENSITY	OPERATION	TAPE ADAPTER UNIT INTERLOCKED MS	APPROXIMATE PROCESSING TIME AVAILABLE		APPROXIMATE GAIN IN PROCESSING TIME MS
				WITHOUT OVERLAP MS	WITH OVERLAP MS	
729 II	High	Read	10.7 + CN	0.2	6.8	6.6
		Write	11.7 + CN	4.2	11.5	7.3
	Low	Read	11.1 + CN	0.6	11.1 + .055N	10.5 + .055N
		Write	12.1 + CN	4.6	12.1 + .055N	7.5 + .055N
729 IV	High	Read	6.8 + CN	0.1	4.5	4.4
		Write	7.8 + CN	2.8	7.7	4.9
	Low	Read	7.1 + CN	0.4	7.1 + .031N	6.7 + .031N
		Write	8.1 + CN	3.1	8.1 + .033N	5.0 + .033N
729 V	High (556 or 800)	Read	10.7 + CN	0.2	6.8	6.6
		Write	11.7 + CN	4.2	11.5	7.3
	Low (200)	Read	11.1 + CN	0.6	11.1 + .055N	10.5 + .055N
		Write	12.1 + CN	4.6	12.1 + .055N	7.5 + .055N
7330	High	Read	20.5 + CN	12.8	20.5 + .036N	7.7 + .036N
		Write	20.3 + CN	15.3	20.3 + .038N	5.0 + .038N
	Low	Read	21.1 + CN	13.2	21.1 + .127N	7.9 + .127N
		Write	20.9 + CN	15.9	20.9 + .127N	5.0 + .127N

Figure 251. Summary of Available Processing Time

Disk Storage Access Time

To calculate timing for magnetic disk operations, it is necessary to estimate the average time it takes to seek the records needed for a particular application. If input to the operation is in sequence, the average access time is less than if the input data is unsorted. This can be explained by the fact that the duration of the seek depends on how far the access arm must travel.

To seek a track on another disk, the access arm moves horizontally, vertically, and horizontally again. The minimum time to move from the outside track of

one disk to the outside track of an adjacent disk is 415 milliseconds. The maximum length of a seek operation is from the inside track of the top disk to the inside track of the bottom disk and takes 800 milliseconds. Figure 252 shows track-to-track access times.

To seek a different-track on the same disk (top or bottom face), the arm moves horizontally only. In this case, minimum seek time is 90 milliseconds and maximum seek time is 250 milliseconds (Figure 253).

Disk-to-disk access time ranges from 100 to 315 milliseconds. Figure 254 shows timing for these operations.

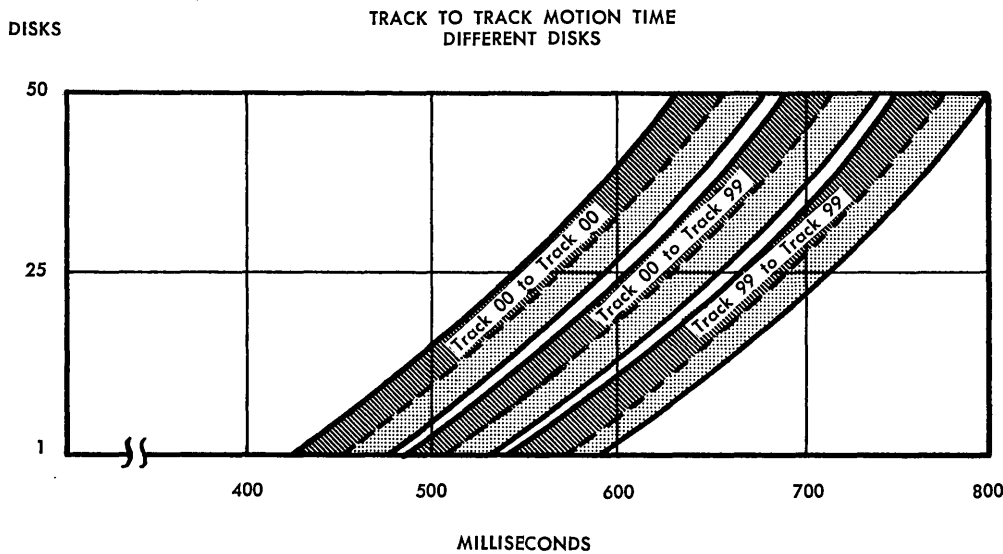

Figure 252. Track-to-Track Motion Time—Different Disk

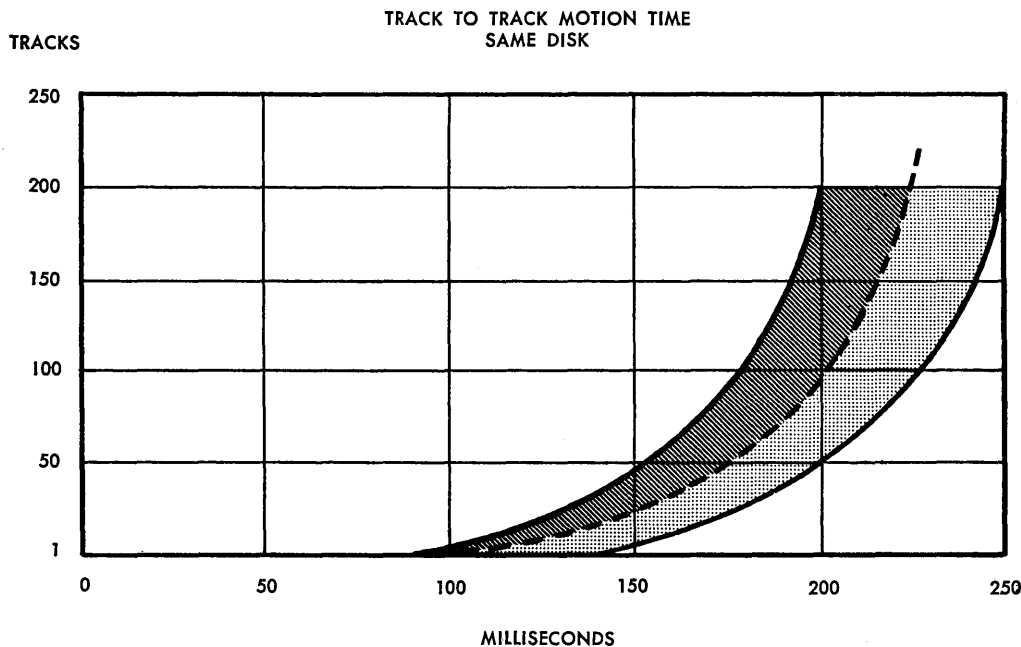

Figure 253. Track-to-Track Motion Time—Same Disk

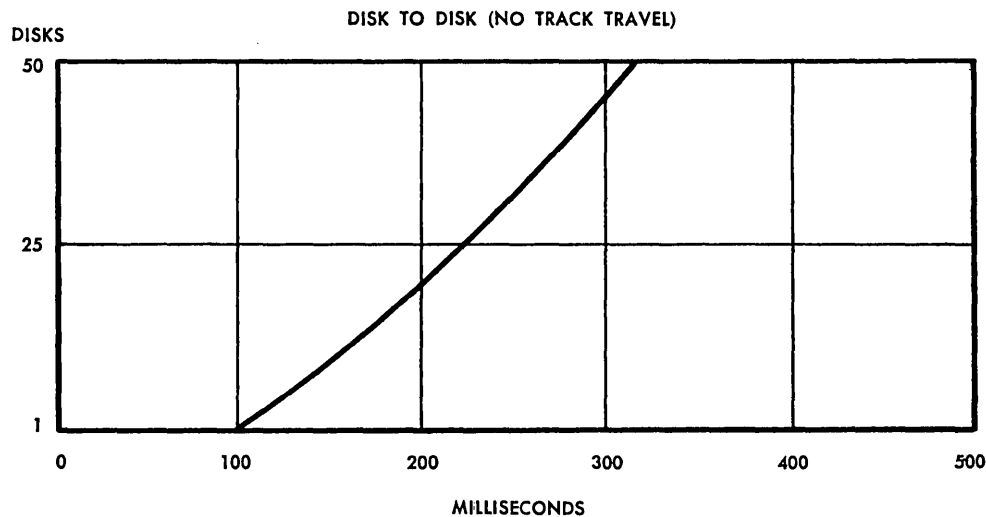

Figure 254. Disk-to-Disk Travel (No Track Travel)

Total Job Time

It is important to estimate the total time required to complete the processing of each job considered for a data processing system application. One suggested approach that can be used to calculate total 1401 time is outlined here:

1. Design a general flow-chart of the machine operation.
2. Analyze the operation and determine where input-output operations can be combined effectively. For example, a combination read and punch instruction can sometimes be used to save time if a card is to be punched for each card read.
3. Determine the amount of processing time required. This can be done by drawing a block diagram and estimating the type and number of program steps in each block. In most cases, an average instruction

time of .25 ms can produce a rough timing estimate. In some special cases it may be necessary to program portions of the program and determine actual timing from the formulas provided.

4. After processing time is calculated, the proper placing of input-output instructions in the program must be determined to insure that enough processing time is available between input-output interlocks.

Note: If magnetic tape operations are performed, tape timing must also be calculated to determine overlapping with print operations if print storage is installed.

5. After all cycle lengths and overlapping have been established, calculate the total 1401 time for each type of record including input, processing, and output, for each transaction and multiply by the job volume.

Appendix

Form Design

Some of the customary rules for designing forms should be reconsidered in the light of the many new features introduced by the IBM 1403 Printer.

1. The print unit contains 100 print positions in a 10.0-inch width or a maximum of 132 print positions (special feature) in a 13.2-inch width. Each print position can print any character.
2. Editing, high-speed skipping and other features are included in the system.

One of the basic tools used in designing forms is the spacing chart shown in Figure 255. The numbers across the top from 0 to 13 represent the tens and hundreds positions of the print-position number, and the numbers directly beneath represent the units position of the print-position number. Print-position 42 can be located by referring first to the 4 column and then to the digit

2 within the 4 column. Print-position 9 can be located by referring to the 0 column and then to the digit 9 within that column.

A facsimile of the carriage-control tape is shown at the left (in Figure 255) for marking the control punching for a specific form. Notations have been included relative to standard form-widths and form-depths, lateral movement of the carriage, and instructions to forms manufacturers.

The IBM 1403 Printer carriage is designed to feed marginally-punched continuous forms satisfactorily under the conditions and specifications outlined in Figure 256. These specifications, if followed, give maximum operating efficiency when the 1403 carriage is used. They are not intended to be restrictive, but rather they are intended to permit customers to purchase their continuous forms from the manufacturer of their choice.

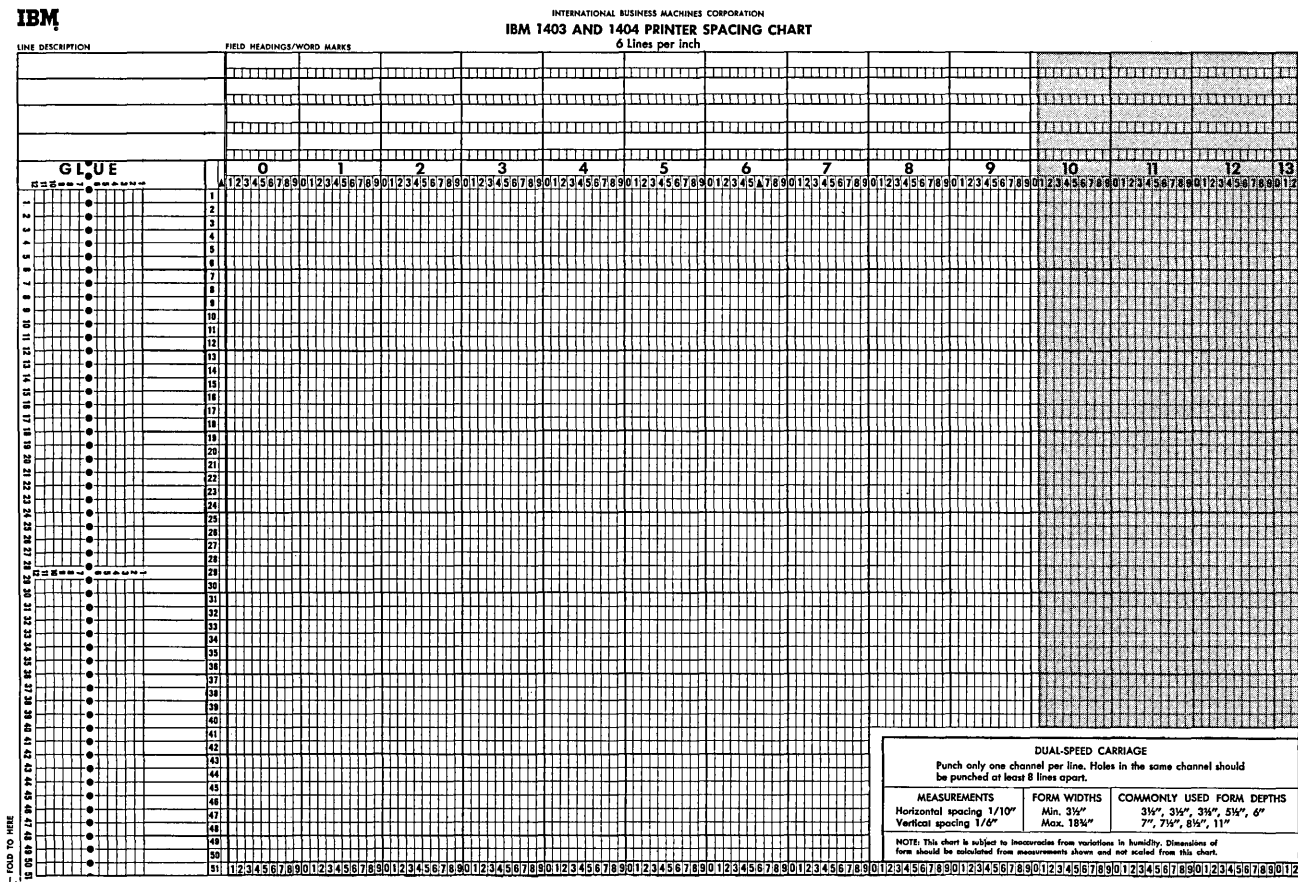

Figure 255. Forms Spacing Chart

Form Design as Affected by the Print Unit

In view of the 100 or 132 print positions and the 13.2-inch print unit, these factors should be considered when designing forms to be used on the IBM 1403 Printer:

1. The maximum form width is 18¾ inches, and the minimum is 3½ inches (see Figure 256).
2. The maximum form length is 22 inches at six-lines-per-inch spacing, or 16½ inches at 8 lines per inch. For efficient stacking of forms, the recommended maximum forms length is 17 inches.
3. Because all print positions can print all characters, form depth can be reduced, and carbon paper eliminated, by the use of side-by-side printing. For

example, *sold to* and *ship to* names can be printed on the same line, one on the left side of the form and the other on the right.

4. Forms can be designed for printing six or eight lines to the inch. Single-space, eight-lines-per-inch printing is not recommended when the registration between lines is critical.
5. Forms can be designed for variable line spacing within a form by use of single-, double-, or selective-space control.
6. It is possible to dispense with many vertical lines, because the system can be programmed to print commas, decimals, oblique lines, dashes, and other symbols.
7. A vertical line should not be printed between two

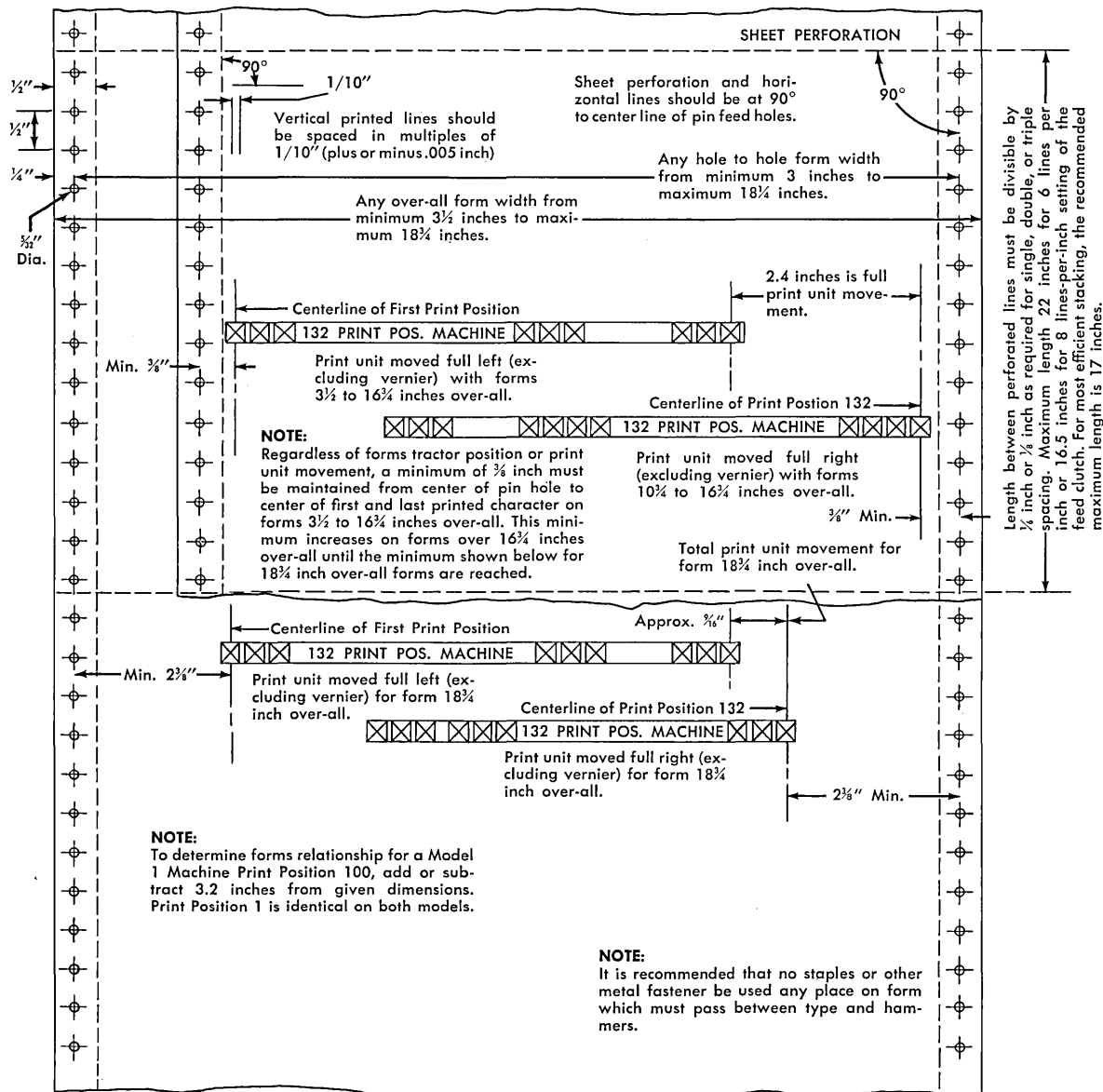

Figure 256. Form with Specifications

adjacent printing positions because there is an over-all maximum tolerance of only .013 inch between adjacent characters.

8. The number of legible copies that can be produced depends on the weight of the paper used for each form, and on the carbon coating.

Because the striking force of the print hammers is not adjustable, paper and carbon should be tested in conjunction with the print-density control-lever and the print timing dial.

9. The CR (credit symbol) prints from two print positions and the minus sign prints from one. For this reason the minus sign is recommended as a credit symbol instead of the CR symbol.
10. The dollar symbol does not have to be preprinted on a check form, because this symbol can be programmed to print immediately to the left of significant digits.

Form Specifications and Dimensions

PAPER CHARACTERISTICS

The paper used for continuous forms must be of sufficient weight and strength to prevent the holes from tearing out during feeding or ejecting of the form. This is particularly important when single-part forms are being used.

The paper must not be so stiff as to cause improper feeding or excessive bulging, particularly at the outfold.

Paper must be as free from paper dust or lint as possible.

WEIGHT

The number of legible copies required is a factor in determining the weight of the paper to be used in a multiple-part set.

Best results on multiple-copy forms require a light-weight paper of 13 pounds or less, except for the last copy. Again, the number of copies, as well as the distance of the form away from the hammers (this distance can be varied by use of the print-density control-lever), affects the determination of paper weight.

Feeding and legibility performance can best be determined by making test runs of sample sets of forms.

FRICTION

During the feeding operation, friction on marginally-punched continuous forms should be eliminated by the following means:

1. Place the pack of forms directly beneath the front of the printer on the forms stand, in a position that eliminates any abnormal *drag* on the forms.

2. Allow sufficient clearance between the hammers and the print chain, to permit the forms to be fed by the pins freely, and without interference. This can be accomplished by properly setting the print-density control-lever.

PERFORATED LINES

The perforations between forms should be sufficiently deep to permit easy separation, but not so deep as to tear in ordinary handling or feeding through the machine.

The perforated lines at the end of the form should always be located at 90 degrees to a vertical center line through the marginal holes.

Cut and uncut portions should be uniformly accurate in length and spacing to insure proper and efficient tearing.

Vertical perforations, at the margin for removal of the marginally punched strip, can vary, depending upon requirements. The distance from the edge of the form to the marginal perforations is usually $\frac{1}{2}$ inch.

MARGINAL HOLES

Continuous forms should have holes in both right and left margins, $\frac{1}{2}$ inch in diameter, spaced vertically $\frac{1}{2}$ inch apart from center to center, the full length of the form. The holes should be located this way on all copies of all sets throughout each pack of forms.

It is possible, however, to use holes of any size, shape, and spacing that accomplish the equivalent feeding conditions.

Vertical lines passing through the two vertical rows of pin holes must be parallel. It is recommended that the edges of the form be $\frac{1}{4}$ inch from the vertical center lines through the holes.

A horizontal line passing through the center of any two marginal holes on the same line should be at a 90-degree angle to either vertical center lines through the marginal holes.

Spacing between holes, center-to-center, must be such that the pins in the forms tractor, $\frac{1}{8}$ inch in diameter and spaced $\frac{1}{2}$ inch apart, enter and leave the holes in the paper, freely without tearing the paper.

WIDTH OF FORMS

Although forms of any width within the extremes of those shown in Figure 256 can be used, it is recommended that form widths be confined to the standard sizes shown in Figure 257.

LENGTH OF FORMS BETWEEN PERFORATED LINES

The 1403 accommodates marginally-punched continuous forms up to a maximum length of 22 inches, at

OVER-ALL WIDTH (INCHES)	HOLE-TO-HOLE (INCHES)
4 $\frac{3}{4}$	4 $\frac{1}{4}$
5 $\frac{3}{4}$	5 $\frac{1}{4}$
6 $\frac{1}{2}$	6
8	7 $\frac{1}{2}$
8 $\frac{1}{2}$	8
9 $\frac{1}{2}$	9
10 $\frac{5}{8}$	10 $\frac{1}{8}$
11	10 $\frac{1}{2}$
11 $\frac{3}{4}$	11 $\frac{1}{4}$
12	11 $\frac{1}{2}$
12 $\frac{27}{32}$	12 $\frac{11}{32}$
13 $\frac{5}{8}$	13 $\frac{3}{8}$
14 $\frac{7}{8}$	14 $\frac{5}{8}$
15 $\frac{1}{2}$	15
16	15 $\frac{1}{2}$
16 $\frac{3}{4}$	16 $\frac{1}{4}$
17 $\frac{25}{32}$	17 $\frac{9}{32}$

Figure 257. Standard-Size Forms

6-lines-per-inch. It is recommended, however, that form lengths be confined to regular lengths, such as 3, 3 $\frac{1}{3}$, 3 $\frac{1}{2}$, 3 $\frac{2}{3}$, 4, 4 $\frac{1}{4}$, 5, 5 $\frac{1}{2}$, 6, 7, 8, 8 $\frac{1}{2}$, 10, 11, 12, 14, 16, and 17 inches.

LINE SPACING

The forms tractor of the IBM 1403 can be set by the operator for single-space printing, 6- or 8-lines-per-inch. For 6-lines-to-the-inch spacing, the length of the form must be evenly divisible by $\frac{1}{6}$ inch for single spacing, by $\frac{1}{3}$ inch for double spacing, and by $\frac{1}{2}$ inch for triple spacing. Similarly, 8-lines-to-the-inch spacing requires that the length of the form be evenly divisible by $\frac{1}{8}$ inch for single spacing, by $\frac{1}{4}$ inch for double spacing, and by $\frac{3}{8}$ inch for triple spacing.

Single-space, 8-lines-per-inch printing on the 1403 is not recommended when the registration between lines is critical.

MULTIPLE COPIES

Multiple-copy forms consisting of more than four parts, and forms with the first part made of paper of more than 13-pound weight, should be tested under operating conditions to determine the suitability of feeding and legibility.

If multiple-copy forms are not fastened together, the carbon paper must be kept in line with the form by an acceptable method. One such method is center carbon without pin holes, glued to the set, or full-width carbon paper punched with substantially larger marginal holes that are approximately centered with the

corresponding holes in the form. Marginal holes in the carbon that are substantially larger than the corresponding holes in the forms make allowance for carbon shrinkage and provide the processing tolerance necessary for some of the commonly used form structures.

One-time carbon paper or carbon-backed paper can be used. The carbon paper or coating should produce the required number of legible copies without excessive smudging. This can be determined best by making test runs with sample sets of forms containing different qualities of carbon papers.

FASTENING OF MULTIPLE-COPY FORMS

The width, length, and number of copies of the form determine the fastening requirements for satisfactory feeding through the forms tractor. For most efficient stacking, however it is recommended that a suitable fastening method always be used with multiple copy forms.

If the construction of the form is such that the parts are of different widths, the necessity for, and the method of, fastening the form should be determined by the width of the parts, the depth of the form, and weight of paper (shown in Figure 258).

FORM DEPTH (Inches)	MAXIMUM DISTANCE BETWEEN FASTENINGS (Inches)
1 to 5	5
5-1/5 to 11	11
11 to 14	7
14 to 17	8 $\frac{1}{2}$

Figure 258. Fastening Requirements for Multiple-Copy Forms

Forms of fanfold construction can be used on the IBM 1403 Printer.

When card-tag or rag-content paper stock is used, a test of sample sets of forms should be made to determine the exact fastening requirements. The fastening may consist of any satisfactory method, such as stitching or gluing, that prevents the copies from shifting. It is essential, however, that whatever fastening medium is used should not impair the feeding or printing alignment of the form.

REGISTRATION OF FORMS

The assembly of multiple-copy forms should insure that the punching and printing of all copies of the form

are in absolute registration with the material printed by the 1403. The following tolerances should be maintained.

Vertical Lines: Vertical columns of print positions are spaced 1/10 inch apart. There are 50 printing spaces in 5 inches. Vertical rules printed on a form should be spaced in multiples of 1/10 inch.

The center line of any one character, with reference to any other character on the same line, may have a plus or minus tolerance of .0065 inch, or a maximum over-all tolerance of .013 inch. From a forms viewpoint, it is practically impossible to guarantee that the cumulative tolerance of printing-plate shrinkage, paper shrinkage, and marginal-hole perforations does not exceed .0065 inch. This precludes the possibility of retaining satisfactory registration if vertical rules are spaced to split between print positions.

Where vertical lines are required, such rules should split the respective print position, thereby assigning that particular position for the columnar field (dollars and cents, for example) separation. However, in view of the fact that the 1403 can print special characters such as period and comma in every print position, the use of these symbols as decimal points, etc., avoids the need for vertical lines for such separations.

Vertical printed lines should parallel a vertical center line passing through the marginal holes.

Horizontal Lines: Horizontal printed lines on the form should be at a 90-degree angle to the vertical center line passing through the paper-feed pin holes.

The spacing should conform to the setting of the 1403 forms tractor—6- or 8-lines-to-the-inch.

Margins: It is recommended that no staples or other metal fasteners be used with multiple-copy forms. If unavoidable, it is important that, by careful use of printer area of storage (positions 201-332), either the left or right margin (whichever has the staples) be set outside the print hammer area, so that staples or other metal fasteners do not pass between the chain and hammer unit.

Program Loading Routine

This is a procedure for loading information into the IBM 1401 Data Processing System. It is not the only method that can be used, but it is typical of methods used by programmers.

This loading procedure pre-supposes use of an instruction card format as shown on the chart in Figure 259.

The rules to be followed in preparing each of the 6 types of instruction cards used for loading are:

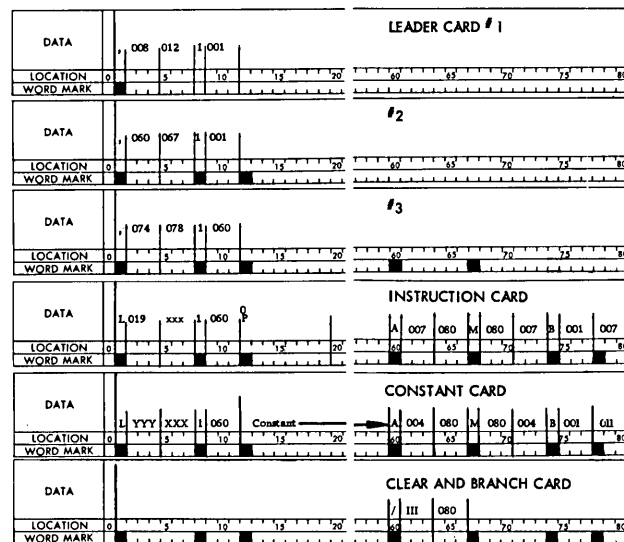

Figure 259. Instruction Cards

Rule 1

Card formats must follow those shown in the storage-layout chart. The first three cards are used to set word marks necessary for succeeding operations.

Card 1. Does not need a work mark for location 001.

The load key automatically sets a program to this location. No word mark is necessary for location 008 for the first card. The 1401 recognizes the end of a SET WORD MARK instruction when it has placed seven characters into the program registers. The card sets word marks in locations 008 and 012, initiates the reading of card 2, and branches to location 001.

Card 2. Sets two word marks for locations 060 and 067, initiates the reading of card 3 and branches to location 001.

Card 3. Sets two word marks, for locations 074 and 078. It causes card 4 to be read, and branches to location 060 for the next instruction.

Instruction Card. A standard load card. The information contained in card columns 1-4, 8-11, and 60-80 is constant, and should be pre-punched. The data punched in card columns 5-7 identifies the location of the instruction (high-order position). The instruction to be loaded is punched starting in card-column 12, and may continue through card-column 19.

Constant Load Card. The length of the constant can vary from 1 character to 48 characters. The constant load card is a standard card and may be pre-punched. The location (XXX) of variable data

(units position) is in columns 5-7. The constant to be loaded is in card columns 12-59, and the number of characters (YYY) to be loaded is in columns 2-4.

Note: The information to be pre-punched differs from that pre-punched in the instruction load cards.

Trailer Card. Used to clear input area and to branch to the first program step.

Rule 2

Pressing the load key on the reader causes an instruction card to feed, places the contents of the card into locations 001 through 080, and automatically starts execution of the load program at location 001. This elimi-

nates the need for manual setting of console dials in preparation for loading.

Clear Storage Routine

This is a procedure that can be used to prepare core storage to accept program and data information. This is not the only clearing routine that can be used; others are left to individual creativity of the programmer.

The following two-card program (Figure 260) can be used to clear storage of all characters and word marks. The character in column 27 of card 2 is variable according to the number of storage positions available.

- T for 1400 positions
- Z for 2000 positions
- I for 4000 positions

IBM 1401 PROGRAM CHART										PRINTED IN U.S.A.		
Card 1 of 2										Program: CLEAR STORAGE		
Programmer: _____										Date: _____		
Step No.	Inst. Address	O P	Instruction				Remarks	Effective No. of Characters				
			A/I	B	d	Inst		Data	Total			
001	I	008	015				Set Word Marks in Read Area					
008	I	022	026				"					
015	I	030	034				"					
022	I	041					"					
026	I	045					"					
030	I	053					"					
034	I	057	073				"					
041	I	026					Read and Branch to 026					

IBM 1401 PROGRAM CHART										PRINTED IN U.S.A.		
Card 2 of 2										Program: CLEAR STORAGE		
Programmer: _____										Date: _____		
Step No.	Inst. Address	O P	Instruction				Remarks	Effective No. of Characters				
			A/I	B	d	Inst		Data	Total			
001	L	072	116				Load Instructions into Punch Area					
008	I	105	106				Define Instructions in					
015	I	110	117				Punch Area					
022	B	101					Branch to Punch Area					
026	/	199					Clear Block of Storage					
030	I	027					Modify Clear Instruction					
034	A	075	029				to Next Lowest					
041	I	027					Century Block					
045	B	001	027	0			Check for Clear Address of 099					
053	B	026					Branch to Clear Block of Storage					
057	/	099					Clear 099 to 000					
061	I						Read Card					
062	I	001					Set Word Mark in 001					
066	/	001	117				Clear Punch Area					
073		100					Constant					
							Column 27 contains an I for a					
							Model 3 1401, a Z for a Model 2 1401					
							and a T for a Model 1 1401					

Figure 260. Clear Routine

Multiplication and Division Subroutines

These are subroutines for multiplication and division operations, discussed here to illustrate programming methods and to aid programming for machines not equipped with the multiply-divide special feature. These are not the only methods of performing these operations — they are typical methods.

Multiplication

The block diagram in Figure 261 illustrates the logic used in developing the two multiply subroutines discussed here. Both subroutines provide for a maximum

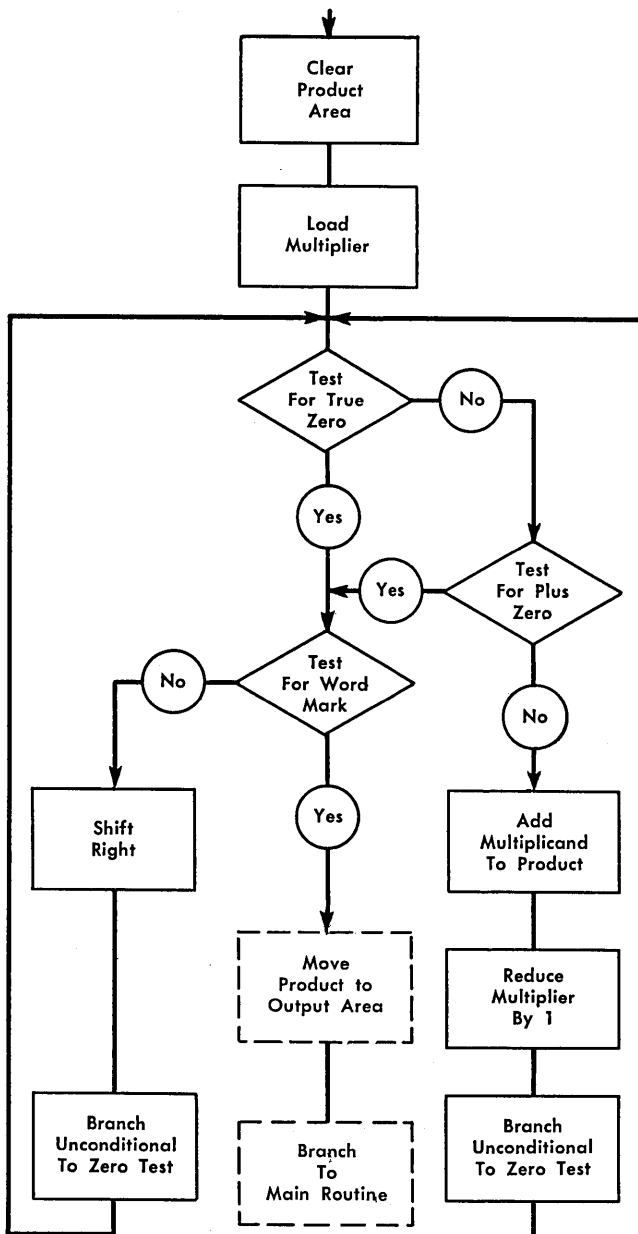

Figure 261. Multiply Flow Chart

of a 9-digit multiplier, 11-digit multiplicand, and a 20-digit product. Both routines use positive factors.

The subroutine written in actual language (Figure 262) occupies the 900 block of storage. A multiplier area is provided in storage positions 901-909, and the product area is assigned in storage positions 910-929. The multiplicand can be located anywhere.

Any program that uses this subroutine must include a step that moves the multiplier address (XXX) to location 937 and the multiplicand address (YYY) to location 952.

At the completion of the multiply subroutine, the program instruction step 12 can use a branch to the main program or stop instruction.

The routine starts in storage position 930. The product is found in 929 for a 9-digit multiplier, 928 for 8-digit, 927 for 7-digit, 926 for 6-digit, etc.

The subroutine written using the symbolic programming system (Figure 263) parallels the one written in actual. In this instance, the 1401 (through the processor program) controls the location of the instructions, and the data and work areas.

IBM 1401 PROGRAM CHART									
Program: Multiply Subroutine									
Programmer:						Date:			
Step No.	Inst. Address	O P	Instruction			Remarks	Effective No. of Characters		
			A/I	B	d		Inst	Data	Total
1	930	/	929			Clear Product Area	4		
2	934	L	XXX	909		Load Multiplier	7		
3	941	B	975	909	0	Test 909 for true zero	8		
4	949	B	975	909	?	No true zero - test for plus zero	8		
5	957	A	YYY	921		No zero - add Multiplicand to Product	7		
6	964	S	994	909		Reduce Multiplier by 1	7		
7	971	B	941			Branch to zero test	4		
8	975	V	995	909	1	Test 909 for Word Mark	8		
9	983	L	928	929		No Word Mark - Shift Right	7		
10	990	B	941			Branch to zero test	4		
11	994	I				Constant "1"	1		
12	995	B	ZZZ			Multiplication complete - Branch back to Program			
			XXX			Location of Multiplier			
			YYY			Location of Multiplicand			
			ZZZ			Address of next Program Step			
						9 digit Multiplier			
						11 digit Multiplicand			
						20 digit Product			

Figure 262. Multiply Subroutine (Actual)

IBM		1401		Symbolic Programming System		Coding Sheet		Page No. <u>1</u> of <u>2</u>						
Program <u>Multiply Subroutine</u>		Date _____		Identification <u>76</u> <u>80</u>										
LINE	COUNT	LABEL	OPERATION	(A) OPERAND				(B) OPERAND				d	COMMENTS	
				ADDRESS	±	CHAR. ADJ.	IND.	ADDRESS	±	CHAR. ADJ.	IND.			
010			LC	A	ZEROS			AREA						CLEAR PROD AREA
020			LC	A	MPLI ER			AREA	-020					LOAD MPLI ER
030		ZROTST	B		TESTWM			AREA	-020					0 BRANCH TRUE ZERO
040			B		TESTWM			AREA	-020					? BRANCH PLUS ZERO
050			A		MCAND			AREA	-008					ADD MCAND
060			S		ONE			AREA	-020					SUBI FROM MPLI ER
070			B		ZROTST									BRANCH TO ZROTST
080		TESTWM	BWZ		LAST			AREA	-020					1 TEST FOR WM
090			LC	A	AREA	-001		AREA						SHIFT AREA RT 1
100			B		ZROTST									BRANCH TO ZROTST
110		LAST	B		0000									MULT COMPLETE
120														
130														
140														
150														
160	30	ZEROS	DCW*											
170	30	AREA	DCW*											
180	9	MPLI ER	DCW*											
190	11	MCAND	DCW*											
200	1	DONE	DCW*			1								

Figure 263. Multiply Subroutine (Symbolic)

Note: The multiplication subroutine results in blanks instead of zeros in the low-order position of a product when the multiplier contains low-order zeros. To correct this situation, set the product area to zeros.

Division

The restrictions placed on this subroutine (Figures 264 and 265) are:

1. The dividend and quotient fields must be of equal length.
2. The dividend and divisor must both be positive.
3. The divisor must have no zone for its positive indication. This is necessary only if the divisor could be zero.
4. The divisor cannot contain more than nine leading zeros.
5. All fields must be located completely below address 999.
6. At the completion of the subroutine, the address of

the units position of the quotient can be found in the B-address of the instruction located in 651.

7. The remainder is left in the dividend field.
8. A word mark must be located immediately to the right of the units position of the dividend.
9. The quotient area must be preset to zeros or blanks to develop the correct quotient. If the area is not zeroed or blanked, then the quotient will be added to whatever is there. The positions added will depend on the number of leading zeros in the divisor.
10. The information shown in *Data for Division Subroutine*, except the constant 1 in location 513, must be set initially for each desired execution of the divide subroutine. The two addresses in locations 507 and 510, associated with the divisor, are not altered. Thus, they do not have to be reinitialized if the divisor is contained in the same area.

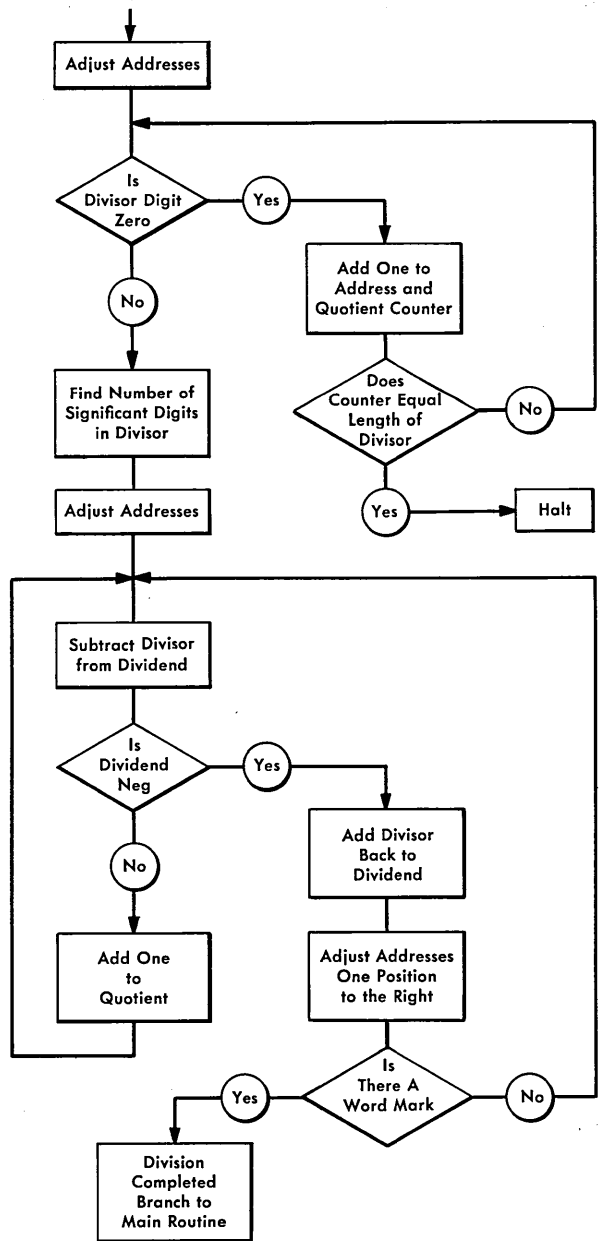

Figure 264. Divide Flow Chart

IBM 1401 PROGRAM CHART FORM X264437-0
PRINTED IN U.S.A.

Program: DIVIDE ROUTINE EXAMPLE Page 1 of 2

Programmer: _____ Date: _____

Step No.	Inst. Address	Instruction				Remarks	Effective No. of Characters		
		O	A/I	B	d		Inst	Data	Total
516	M	507	529			Store Address of Word Mark Position (High Order) of Divisor			
523	B	662	YYY	0		Branch if Divisor Digit Equals Zero (Number of High Order Zeros)			
531	S	512	515						
538	A	515	501			Adjust Dividend Address			
545	A	515	504			Modify Addresses			
552	S	513	501						
559	S	513	504						
566	Y	755	501			Clear zone from low-order position to prepare for address assignment.			
573	Y	755	504			Clear zone from low-order position to prepare for address assignment.			
580	M	501	642			Set Modified Addresses into Divide Routine			
587	M	501	649						
594	M	501	698						
601	M	501	705						
608	M	501	719						
615	M	504	657						
622	M	510	639			Set Divisor Address			
629	M	510	695						
636	S	ZZZ	WWW			Subtract Divisor from Dividend			
643	V	692	WWW	K		Branch if Negative Result			
651	A	513	XXX			Add One to Quotient			
658	B	636				Repeat Subtraction			
662	A	513	529			Add One to YYY Address			
669	A	513	512			Increase Counter by One			
676	C	512	515			If Equal, Divisor Equals Zero			
683	B	523				Branch Unequal			
688	.	760				Halt - cannot Divide by Zero			
692	A	ZZZ	WWW			Add Divisor to Dividend			
699	Y	755	WWW			Move blank zone to word mark position of dividend			
706	A	513	719						
713	V	760	WWW	1		Test for End of Divide			
721	A	513	642			Modify Addresses to Develop Next Quotient Digit			
728	A	513	649			" " " "			
735	A	513	657			" " " "			
742	A	513	698			" " " "			
749	A	513	705			" " " "			
756	B	636				Return to Divide Calculations			
760						Divide Complete			

DATA FOR DIVISION SUBROUTINE

Location of Data Word	Data Word	DESCRIPTION OF DATA
501	WWW	Address of word mark position (high order) of dividend
504	XXX	Address of word mark position (high order) of quotient
507	YYY	Address of word mark position of divisor
510	ZZZ	Divisor Address
512	00	Counter for number of zeros in divisor
513	1	Constant
515	NN	Length of the divisor

Figure 265. Divide Subroutine

OPERATION CODE	FUNCTION	MNEMONIC	BCD CODE	CARD CODE	OPERATION CODE	FUNCTION	MNEMONIC	BCD CODE	CARD CODE	INSTRUCTION	FUNCTION	MNEMONIC	BCD CODE	CARD CODE
INPUT-OUTPUT CODES					MISCELLANEOUS OPERATION CODES					MAGNETIC TAPE %UX TAPE UNIT ADDRESS				
1	Read a Card	R	1	1	C	Compare	C	CBA21	12-3	L(%UX)(B)d	Read/Write Tape with Word Marks	LCA		d-modifier, R-Read Tape W-Write Tape
2	Write a Line	W	2	2	E	Move Characters and Edit	MCE	CBA41	12-5	M(%UX)(B)d	Read/Write Tape	MCW		
2 □	Write Word Marks		□ is modifier		F	Control Carriage	CC	CBA42	12-6	M(%CX)(B)R	Read Compressed Tape*			(%CX) is address of tape unit
3	Write-Read	WR	C21	3	H	Store B-Address Register*	SBR	BA8	12-8	P(A)(B)	Move Characters to Record or Group Mark*	MCM	CB421	11-7
4	Punch a Card	P	4	4	K	Select Stacker	SS	CB2	11-2	U(%UX)d	Control Unit	CU	CA4	0-4
4R	Read-Punch Feed*		R is modifier		N	No Operation	NOP	B41	11-5	X(A)(B)	Move and Insert Zeros*	MIZ	CA421	0-7
4(I)R	Read-Punch Feed and Branch*		R is modifier		Q	Store A-Address Register*	SAR	CB8	11-8	INSTRUCTION FUNCTION REMARKS				
5	Read-Punch	RP	C41	5	/	Clear Storage	CS	CA1	0-1	COLUMN BINARY				
6	Write-Punch	WP	C42	6	.	Halt	H	BA821	12-3-8	1C	Read Column Binary	C is Modifier		
6R	Write-Read Punch Feed*		R is modifier		#	Modify Address*	MA	821	3-8	4C	Punch Column Binary	C is Modifier		
6(I)R	Write-Read Punch Feed and Branch*		R is modifier		CHARACTER AT d FOR B(I)d BRANCH					M(A)(B)A	Move and Binary Decode	A is Modifier		
7	Write-Read-Punch	WRP	421	7	d	BRANCH ON	d	BRANCH ON		M(A)(B)B	Move Binary Code	B is Modifier		
8	Start Read Feed*	SRF	8	8	b1	Unconditional	R	Carriage Busy*		M(%BX)(A)R	Read Binary Tape	%BX is Address of tape unit		
9	Start Punch Feed*	SPF	C81	9	9	Carr. Chan. #9	T	Low Compare B < A*		M(%BX)(A)W	Write Binary Tape	%BX is Address of tape unit		
ARITHMETIC CODES					A	"Last Card" Switch	U	High Compare B > A*		W(I)(B)d	Branch if Bit Equal	BBE is mnemonic		
A	Add	A	BA1	12-1	B	Sense Switch B*	Z	Overflow		DISK STORAGE %FX DISK OPERATION				
5	Subtract	S	CA2	0-2	C	Sense Switch C*	?	Reader Error if I/O Check Stop Switch OFF		M(%F0)(B)R	Seek Disk	B is Disk Address		
?	Zero and Add	ZA	CBA82	12-0	D	Sense Switch D*	!	Punch Error if I/O Check Stop Switch OFF		M(%FX)(B)R	Read Disk	X can be 1, 2, or 3		
!	Zero and Subtract	ZS	B82	11-0	E	Sense Switch E*	+	Printer Error if I/O Check Stop Switch OFF		M(%FX)(B)W	Write Disk	1 Specifies Single Record		
@	Multiply*	M	CB4	4-8	F	Sense Switch F*	@	Carr. Chan. #12		L(%FX)(B)R	Read Disk with Word Marks	2 Specifies Full Track		
%	Divide*	D	AB4	0-4-8	G	Sense Switch G*	%	Processing Check with Process Check Switch OFF		L(%FX)(B)W	Write Disk with Word Marks	3 Specifies a Write Disk Check operation M(%F3)(B)W		
LOGIC OPERATION CODES					K	End of Reel*	/	Unequal Compare B ≠ A		1407 INQUIRY %TO ADDRESS				
B(I)	Branch	B	BA2	12-2	L	Tape Error*				M(%T0)(B)R	Read Console Printer	Data from 1407 transferred to B-address		
B(I)d	Branch if Indicator ON		d is modifier		S	Equal Compare B = A*				M(%T0)(B)W	Write Console Printer	Data at B-address transferred to 1407		
B(I)(B)d	Branch if Character is Equal		Contents of B compared to d		P	Printer Busy*				L(%T0)(B)R	Read Console Printer with Word Marks	Data from 1407 transferred to B-address with Word Marks		
V(I)(B)d	Branch if WM and/or Zone	BWZ	A41	0-5	CHARACTER AT d FOR MAGNETIC TAPE DISK STORAGE					L(%T0)(B)W	Write Console Printer with Word Marks	Data at B-address transferred to 1407 with Word Marks		
MOVE AND LOAD CODES					d	OPERATION	d	BRANCH ON		1407 INQUIRY %TO ADDRESS				
D	Move Numerical	MN	BA4	12-4	B	Backspace Tape Record	N	Access Inoperable		M(%T0)(B)R	Read Console Printer	Data from 1407 transferred to B-address		
L	Load Character to A Word Mark	LCA	B21	11-3	E	Skip and Blank Tape	V	Read/Write Parity Check or Read Back Check Error		M(%T0)(B)W	Write Console Printer	Data at B-address transferred to 1407		
M	Move Characters to A or B Word Mark	MCW	CB4	11-4	M	Write Tape Mark	W	Wrong-Length Record		L(%T0)(B)R	Read Console Printer with Word Marks	Data from 1407 transferred to B-address with Word Marks		
Y	Move Zone	MZ	CA8	0-8	R	Rewind Tape	X	Unequal Address Compare		L(%T0)(B)W	Write Console Printer with Word Marks	Data at B-address transferred to 1407 with Word Marks		
Z	Move Characters and Suppress Zeros	MCS	AB1	0-9	U	Rewind Tape and Unload	Y	Any Disk Storage Error Condition		M(%T0)(B)W	Line Space	B is address of a Group Mark with a Word Mark		
?	Set Word Mark	SW	CA821	0-3-8	CHARACTER AT d FOR 1407 CONSOLE INQUIRY STATION									
□	Clear Word Mark	CW	CBA84	12-4-8	Q	Inquiry Request	*	Inquiry Clear						
* Special Feature														

PRINTS AS	DEFINED CHARACTER	CARD CODE	BCD CODE	PRINTS AS	DEFINED CHARACTER	CARD CODE	BCD CODE
	BLANK		C	G	G	12-7	B A 4 2 1
.	.	12-3-8	B A 8 2 1	H	H	12-8	B A 8
□	□	12-4-8	C B A 8 4	I	I	12-9	C B A 8 1
	(Left Parenthesis (Special Character)	12-5-8	B A 8 4 1	—	! (Minus Zero)	11-0	B 8 2
	< Less Than (Special Character)	12-6-8	B A 8 4 2	J	J	11-1	C B 1
	≡ Group Mark (Note 1)	12-7-8	C B A 8 4 2 1	K	K	11-2	C B 2
&	&	12	C B A	L	L	11-3	B 2 1
\$	\$	11-3-8	C B 8 2 1	M	M	11-4	C B 4
*	*	11-4-8	B 8 4	N	N	11-5	B 4 1
) Right Parenthesis (Special Char.)	11-5-8	C B 8 4 1	O	O	11-6	B 4 2
	; Semicolon (Special Character)	11-6-8	C B 8 4 2	P	P	11-7	C B 4 2 1
	△ Delta (Mode Change)	11-7-8	B 8 4 2 1	Q	Q	11-8	C B 8
—	—	11	B	R	R	11-9	B 8 1
/	/	0-1	C A 1	±	± Record Mark	0-2-8	A 8 2
,	,	0-3-8	C A 8 2 1	S	S	0-2	C A 2
%	%	0-4-8	A 8 4	T	T	0-3	A 2 1
	= Word Separator	0-5-8	C A 8 4 1	U	U	0-4	C A 4
	' Apostrophe (Special Character)	0-6-8	C A 8 4 2	V	V	0-5	A 4 1
	“ Tape Segment Mark	0-7-8	A 8 4 2 1	W	W	0-6	A 4 2
≠	¢ Cent (Special Character Note 2)		A	X	X	0-7	C A 4 2 1
#	#	3-8	8 2 1	Y	Y	0-8	C A 8
@	@	4-8	C 8 4	Z	Z	0-9	A 8 1
	: Colon (Special Character)	5-8	8 4 1	0	0	0	C 8 2
	> Greater Than (Special Character)	6-8	8 4 2	1	1	1	1
	√ Tape Mark	7-8	C 8 4 2 1	2	2	2	2
&	? (Plus Zero)	12-0	C B A 8 2	3	3	3	C 2 1
A	A	12-1	B A 1	4	4	4	4
B	B	12-2	B A 2	5	5	5	C 4 1
C	C	12-3	C B A 2 1	6	6	6	C 4 2
D	D	12-4	B A 4	7	7	7	4 2 1
E	E	12-5	C B A 4 1	8	8	8	8
F	F	12-6	C B A 4 2	9	9	9	C 8 1

The 1401 has the ability to read MLP card codes in the read feed only. The 1401 ignores the 8-9 punches when they appear in the same column. The 1401 does not punch out MLP card codes.

Note 1. If specified, this code can be made compatible with 705 Group Mark Code (12-5-8).

Note 2. The A-bit coding must be program generated in the 1401 (it cannot be read from a card; it can be punched as a zero). It is used in conjunction with the C-bit to indicate a blank position on tape that was written in even-bit parity.

Note 3. Other special character printing arrangements can be obtained.

Figure 267. IBM 1401 Character Code Chart in Collating Sequence

A-Address	16	B Special Character, 1407	72
A-Address Register	19	Backspace Key	114
A-Address Register Key-Light	111	Backspace Tape Record	60
A- and B-Auxiliary Register Key-Lights	111	Batching	12
A-Light	109	BCD Code and Column Binary Punches	90
A-Register	20	Binary-Coded Decimal	13
Access Arms	63	Binary Tape Instructions	92
Access Inoperable	68	Bit Configuration, Increased Core Storage	77
Access Lights	128	Bit Display Lights	111
Access Timing	158	Bit Switches	116
Adapter Tray	95	Bit Values	106
Add	29	Body Control Word	41
Add A-Address	29	Branch	32
Add A- and B-Address	29	Branch if Bit Equal	92
Add to Storage	28	Branch if Character Equal	33
Add-to-Storage Logic	12	Branch if End of Reel	62
Additional Print Control Feature	82	Branch if Indicator On	32
Additional Quotient Digits	75	Branch if Indicator On, 1405	68
Address Arithmetic, Increased Core Storage	78	Branch if Indicator On, 1407	73
Address Checking	14	Branch if Indicator On, Overlap Mode	103
Address Codes	18	Branch if Indicator On, Sense Switches	87
Address Compare Light	128	Branch if Overflow Indicator On	29
Address Invalid Light	125, 128	Branch if Tape Error	62
Address Modification	106	Branch if Word Mark and/or Zone	33
Address Modification, Increased Core Storage	78	Branch Indicators, Overlap	103
Address Modification, Indexing	84	Branch Unconditional	32
Address Modification with Indexing Feature	108	Brush Interlock, 1403	122
Address Modification Without Indexing Feature	106		
Address Registers	19	C- and A-Bit Tape Characteristics	54
Address Selection Dial	134	Calculating Processing Time	149
Address Stop	114	Calculating Total Job Time	159
Address Validity Checking	14	Card-Deck Supports	96
Address Validity, Increased Core Storage	77	Card-Feed Schematic, 1402	10
Addressing	18	Card Feeding	10
Addressing, Increased Core Storage	77	Card Punch Timing	141
Addressing System Chart	77	Card Punching Time	45
Adjusting the Secondary Stackers	96	Card Read Instructions	44
Advanced Systems Design	9	Card Reader Timing	140
Algebraic Sign Control, Addition	28	Card Reading Time	44
Algebraic Sign Control, Division	75	Carriage Busy Indicator	82
Algebraic Sign Control, Multiplication	74	Carriage Control Tape	123
Algebraic Sign Control, Subtraction	30	Carriage Controls	120
Alter Key-Light, 1407	129	Carriage Release Buttons, 1407	130
Alter Mode	113	Carriage Restore Key	120
Any Disk Unit Error Condition, 1405	69	Carriage Space Key	120
Appendix	160	Carriage Stop Key	120
Area Definition	23	Carriage Tape Brushes	124
Arithmetic	14	Chain Cartridge Adapter	94
Arithmetic Operations	28	Chaining	20
Arithmetic Operations Sign	28	Chaining Instructions	20
Arithmetic Overflow	29	Character Code Chart	171
Asterisk Control	82	Character Display	113
Asterisk Protection	82	Character Rate Tape	149
Autocoder	23	Character Registers	19, 20
Autocoder Coding Sheet	23	Check Character, Magnetic Tape	53
Autocoder Mnemonics	25	Check Manual Entry of Address Registers	136
Auxiliary Console	116	Check Reset Key, 1401	114
Auxiliary Console Switches	116	Check Reset Key, 1402	118
Auxiliary Mode Switch	116	Check Reset Key, 1403	119
		Check Stop Switch	116
B = A Light	110	Chip Light	118
B \neq A Light	111	Cleaning the Chain	127
B > A Light	111	Clear Key, 1407	71
B < A Light	111	Clear Key Light	129
B-Address	16	Clear, Move, Load and Word Mark Operations	35
B-Address Register	20	Clear Storage	36
B-Address Register After Branch	22	Clear Storage and Branch	36
B-Address Register Key-Light	111	Clear Storage Routine	165
B-Light	109	Clear Word Mark, A-Address	37
B-Register	20	Clear Word Mark, A- and B-Address	37

Coded Addresses	18
Codes, Contents of Address Registers	22
Coding, 1405	63
Coding Sheets	23
Column Binary Feature	89
Column Binary, Punch-Out Area	91
Column Binary, Read-In Area	90
Combination Instructions	48
Combination Print and Punch Timing	147
Combination Print and Read Timing	144
Combination, Print, Read, and Punch Timing	147
Combination Read and Punch Timing	145
Compare	34
Complement Add	28
Compressed Tape Operations Feature	87
Console Inquiry Station	70
Console Inquiry Station Operation	136
Console Inquiry with 1401 in Alter Mode with Inquiry Routine	137
Console Inquiry with 1401 in Run Mode with Inquiry Routine	137
Console Keys, Lights, and Switches	109
Console Operation, 1401	136
Contents, B-Address Register After Branch	22
Contents of Address Register Codes	22
Control Carriage	52
Control Carriage and Branch	52
Control Keys and Switches	114
Control Tape	123
Control Word	41
Core-Storage Address Chart	77
Core-Storage Address Codes	18
CR Symbol, Sign Control Left	83

d-Character	16
d-Characters for Branch Instructions	32
d-Character for Forms Control	52
Data Flow, Magnetic Tape	53
Data Flow, Processing Overlap	98
Decimal Control	84
Declarative Operations	23
Decreasing an Address	106
Decreasing an Address, Indexing	108
Density Switch	134
Density Switch 729 V, Auxiliary Console	117
Disk Storage Access Time	158
Disk Storage Addressing	63
Disk Write Switch	117
Displaying Information	109
Divide	75
Divide, Additional Quotient Digits	75
Divide Times	150
Division Subroutine	167
Document-Control Instructions	51

8-Lines-Per-Inch Spacing	124
Early Card Read Feature	97
Early Card Read Speeds	141
Editing	14, 41
Editing Operation, Step-by-Step	42
Editing Rules	41
Electric Ribbon Rewind, 1407	132
Emergency-Off Switch	115
End-Around Checking	15
End-of-Forms Light	119
End-of-Reel Indicator	60
Enter Switch	116
Entering Information	136
Entering Information in the Alter Mode, 1407	136
Even-Bit Parity Tape	54
Execution Phase	112
Expanded Print Edit Feature	82
Ext I/O Light (External Input-Output Light)	109

Fastening of Multiple Copy Forms	163
Feed Clutch	120
File Feed	10, 95
File-Protection Light	134
File-Protection Ring	56, 57
Floating Dollar Sign	83
Form Design	160
Form Design as Affected by the Print Unit	161
Form Feeding, 1407	132
Form Key-Light, 1407	129
Form Specifications and Dimensions	162
Format, 1407	71
Forms Chart, Standard Sizes	163
Forms Check Light	119
Forms Insertion, 1403	125
Forms Insertion, 1407	133
Forms Movement Time	46, 143
Forms Skipping	123
Forms Spacing Chart	160
Forms Width	162
Friction, Forms	162
Full Storage Print, Auxiliary Mode Switch	116
Full Track	65
Functions of Word Marks	15
Fuse Light	118
Fuse Light, 729, 7330	134

Gate Interlock, 1403	122
Group Mark	58

Halt	35
Halt and Branch	35
High, Low, Equal Compare Feature	86
High-Speed Start, 1403	123
High-Speed Stop, 1403	123
Hole-Count Check	15
Home Position	120
Hopper Side Plates	95
Horizontal Adjustment of Print Mechanism	121
Horizontal Check Character	54

I-Address	16
I-Address Register	19
I-Address Register Key-Light	111
IBM 704	8, 89
IBM 709	8, 89
IBM 727 Magnetic Tape Unit	55
IBM 729 Magnetic Tape Unit	55
IBM 729 Magnetic Tape Unit Operations	57
IBM 729 II, Tape Timings	152
IBM 729 IV, Tape Timings	153
IBM 729 V, Density Switch	117
IBM 729 and 7330 Magnetic Tape Units Operating Keys and Lights	134
IBM 1009 Data Transmission Unit	8
IBM 1011 Paper Tape Reader	7
IBM 1012 Tape Punch	8
IBM 1401 Autocoder	23
IBM 1401 Character Code Chart	170
IBM 1401 Console Keys, Lights, and Switches	109
IBM 1401 Operation Codes	169
IBM 1401 Processing Unit	9
IBM 1401 Programming Systems	23
IBM 1401 Report Program Generator (RPC)	27
IBM 1401 Symbolic Programming System (SPS)	23
IBM 1401 Used with Other IBM Systems	8
IBM 1402 Card Read Punch	10
IBM 1402 Card Read Punch Operating Keys, Lights, and Switches	118
IBM 1402, Processing Overlap	98
IBM 1403 Printer	11
IBM 1403 Printer Operating Keys, Lights, and Switches ..	119

IBM 1404 Printer	8	Lateral Print Vernier	121
IBM 1405 Disk Storage Instructions	65	Length of Forms Between Perforated Lines	162
IBM 1405 Disk Storage Unit	63	Library	12
IBM 1405 Disk Storage Unit Indicator Lights	128	Line Position Reset, 1407	130
IBM 1405 Indicators	68	Line Space	73
IBM 1405, Model 1	63	Line-Space Lever	131
IBM 1405, Model 2	63	Line Spacing, Forms Design	163
IBM 1406 Storage Unit	76	Literals	23
IBM 1406 Storage Unit Models	76	Load Characters to A Word Mark, A-Address	40
IBM 1406, Model 1	76	Load Characters to A Word Mark, A- and B-Address	39
IBM 1406, Model 2	77	Load Key	118
IBM 1406, Model 3	77	Load Rewind Key	134
IBM 1407 Console Inquiry Station	70	Logic	14
IBM 1407 Console Inquiry Station Instructions	71	Logic Block Lights	110
IBM 1407 Console Inquiry Station, Keys and Lights	129	Logic Light	110
IBM 1407 Indicators	73	Logic Operations	32
IBM 1418 Optical Character Reader	8	Longitudinal Redundancy Check Register (LRCR)	56
IBM 1419 Magnetic Character Reader	8	Low-Speed Start, 1403	123
IBM 7070 Data Processing System	8	Low-Speed Stop, 1403	123
IBM 7070 Compressed Tape	87		
IBM 7070 Tape Processing	54		
IBM 7090 Data Processing Systems	8, 89		
IBM 7330 Magnetic Tape Unit	55	Machine Features, 51-Column Feed Feature	95
IBM 7330 Magnetic Tape Unit Operations	57	Magnetic Core Storage	11
IBM 7330 Tape Timings	154	Magnetic Disk Storage	12
IBM 7701 Magnetic Tape Transmission Terminal	8, 55	Magnetic Tape	53
IBM RAMAC 1401 System	63	Magnetic Tape Characteristics	53
IBM Scientific Data Processing Systems	8	Magnetic Tape Operations	57
Imperative Operations	23	Magnetic Tape Operations, Summary	58
Impression and Carriage Control, 1407	130	Magnetic Tape Storage	12
Impression Indicator Lever	130	Manual Address Switches	111
In-Line Data Processing	63	Manual Controls	120
Increased Core Storage	76	Manual Display	136
Increasing an Address	106	Margin-Release Key	130
Increasing an Address, Indexing	108	Margin-Set Key	130
Index Checking	15	Marginal Holes	162
Index Location Addresses	84	Method of Printing	11
Index Locations	84	Methods, Programming	7
Indexing Feature	84	Minus Sign	28
Indicator Panel Lights, 1403	122	Minus Symbol, Sign-Control Left	83
Indicators, Processing Overlap	103	Mnemonics, <i>Autocoder</i>	25
Indicators, Sense Switches	87	Mnemonics, SPS	24
Input-Output Control System (IOCS)	27	Mode-Change Character	88
Input-Output Operations	44	Mode-Change, Compressed Tape	87, 88
Input-Output Storage Assignments	18	Mode Switch	112
Inquiry, 1407	70	Modify Address, A-Address	78
Inquiry Clear, 1407	73	Modify Address, A- and B-Address	78
Inquiry Request, 1407	73	Modify Address Instruction	107
Inquiry Station, Printer	70	Modifying the File Feed	95
Inserting Control Tape in Carriage	124	Modulus 4	106
Installing a Ribbon, 1407	132	Modulus 16	107
Instruction Descriptions	16	Move and Binary Decode	92
Instruction Format	16, 17	Move and Insert Zeros	88
Instruction Format, 1405	64	Move Binary Code	93
Instruction-Length Lights	111	Move Characters and Edit	41
Instruction Loading, Schematic	21	Move Characters and Suppress Zeros	38
Instruction Phase	112	Move Characters to A or B Word Mark, A-Address	38
Instruction Sizes	17	Move Characters to A or B Word Mark, A- and	
Instructions, No-Address	22	B-Address	37
Instructions, Single-Address	22	Move Characters to Record or Group Mark	86
Instructions, 1407	71	Move Numerical	39
Instructions, Processing Overlap	99	Move Record Feature	86
Inter-Record Gap (IRG)	53, 60	Move Zone	39
Interchangeable Chain Cartridge Adapter	94	Multiple-Copy Control Lever, 1407	131
Interchangeable 51-Column Read Feed	95	Multiple-Copy Forms	163
Interlock Conditions, Processing Overlap	104	Multiplication and Division Subroutines	166
Internal Checking	14	Multiplication Subroutine	166
Introduction, 1401 Reference Manual	7	Multiply	74
IOCS (Input-Output Control System)	27	Multiply Divide Feature	74
I/EX Instruction Execution Mode	112	Multiply Times	150, 151
I/O Check Reset Switch	116		
I/O Check Stop Switch	115		
		Negative Sign	28
Keys and Levers, 1407	130	No-Address Instructions	22
		No Operation	34
Language	13	Non-Process Run-Out Punch Key	118
Last Card Indicator, Processing Overlap	104	Non-Process Run-Out Read Key	118
Last Card Switch	87	Numerical Print Feature	94
		Numerical Print Feature, Timing	144

O-Address Register Key-Light	111
O-Flow Light	110
Object Program	23
Odd-Bit Parity Tape	54
Op Code	16
Op-Register	20
Operating Features	109
Operating Instructions, Chain Cartridge	94
Operating Pointers, 729, 7330	135
Operating Pointers, 1407	130
Operation Codes	28, 169
Op-Register Light	111
Other Input-Output Units for the 1401 System	7
Over-Extending, Punch Release Time	79
Over-Extending, Read Release Time	79
Overlap	97
Overlap Light	109
Overlap Off	100
Overlap Off and Branch	100
Overlap On	99
Overlap On and Branch	99
Overlap Timing	156
Paper-Advance Knob	121
Paper Characteristics	162
Paper Release Lever, 1407	131
Paper Scale, 1407	131
Paper Stacker	126
Parity Checking	14
Parity Error, 1407	71, 72
Parity Light, 1405	128
Perforated Lines	162
Pin Feed Platen, 1407	132
Pivot Plate	96
Platen Variable Button	130
Plus Sign	28
Positive Sign	28
Power-Off Switch	115
Power-On Light	118
Power-On Light, 1405	128
Power-On Switch	115
Preface	5
Print and Punch Timing	147
Print and Read Combination Timing	144
Print and Read, Print Storage and Read Release	145
Print and Read Speed	144
Print Check Light	119
Print-Density Control Lever	121
Print Instructions	46
Print-Line Indicator	121
Print, Read, and Punch Timing	147
Print, Read, and Punch Timing Chart	148
Print-Storage Busy Indicator	82
Print Storage Feature	82
Print-Storage Scan, Auxiliary Mode Switch	116
Print Time	46
Print Timing Chart, Numerical Feature	144
Print Timing Chart with Print Storage	143
Print Timing Dial	121
Print Unit Release Lever	121
Printer Characters	11
Printer Error Indicator	82
Printer Light	109
Printer Restart	139
Printer Timing	141
Printing Speeds	143
Process Check Stop Switch with 1407	71, 72
Process Light	109
Processing	14
Processing 7070 Tapes	54
Processing Overlap Feature	97
Processing Overlap Instructions	99
Processing Overlap Timing	156
Processing Time	149
Processing Time, Overlap Card Operations	156
Processing Time, Overlapped Tape Operations	157
Processing Time, Print	46
Processing Time, Punch	45

Processing Time, Read	44
Processing Unit	14
Processing Unit, 1401	9
Processor Control Operations	23
Processor Program	23
Program	7, 19
Program Loading Cards	164
Program Loading Routine	164
Programming Considerations, Processing Overlap	104
Programming Methods	7
Punch a Card	45
Punch a Card in Overlap Mode	102
Punch and Branch	46
Punch and Branch in Overlap Mode	103
Punch Busy, Processing Overlap	103
Punch Check Light	118
Punch Column Binary	91
Punch Column Binary and Branch	91
Punch Cycle	45
Punch Feed Read	80
Punch Feed Read Feature	80
Punch Feed Read Restart	138
Punch Instructions	45
Punch Light	109
Punch Release Feature	78
Punch Release Time, Over-Extending	79
Punch Restart	138
Punch Select	51
Punch Start Time	45
Punch Stop Light	118
Punch Switch	118
Punch Time, Punch Feed Read	80
Punch Timing	141
Punch Timing Chart with Early Card Read	142
Punching in Pre-punched Columns	80
Punching Speeds	143
Punching the Tape	124
RAMAC Light	109
Read a Card	44
Read a Card in Overlap Mode	102
Read and Branch	45
Read and Print, Print Storage and Read Release	145
Read and Punch	49
Read and Punch Timing	145
Read and Punch Timing Charts	146
Read Back Check Error, 1405	68
Read Binary Tape	93
Read Check Light	118
Read Column Binary	89
Read Column Binary and Branch	90
Read Compressed Tape	87
Read Cycle	44
Read Disk, Full Track	65
Read Disk, Full Track with Word Marks	67
Read Disk, Single Record	65
Read Disk, Single Record with Word Marks	67
Read from Console Printer	71
Read from Console Printer with Word Marks	72
Read in Overlap Mode and Branch	102
Read or Write Parity Check, 1405	68
Read out of Storage in the Alter Mode, 1407	137
Read, Punch, and Branch	49
Read Punch Feed	80
Read Punch Feed and Branch	81
R/T Read/Punch, Auxiliary Mode Switch	117
Read Release and Punch Release Feature	78
Read Release Time, Over-Extending	79
Read Select	51
Read Start Time	44
Read Start Time, Read Release	78
Read Switch	118
Read Tape	57
Read Tape in Overlap Mode	101
Read Tape with Word Marks	59
Read Timing	140
Read Timing Charts with Early Card Read	142
Reader Busy, Overlap	103

Reader Light	109	Space Suppression Feature	105
Reader Restart	138	Spacing, 1403	11
Reader Stop Light	118	Spacing Chart, Forms	160
Reading High-Density Tape in Overlap Mode	101	Special Features	74
Reading Speeds	141	Specifications and Dimensions, Forms	162
Ready Light	119	Specifications, Forms	161
Ready Light, 729, 7330	134	Speed, 1402	10
Ready Light, 1405	128	Speed, 1403	11
Recomplementing	28	Speed, 1405	63
Record Address Format, 1405	64	Speed, Early Card Read	97
Record Check Time	152	Speed, Numerical Print Feature	94
Record Length Light	128	Speed, Print and Read Combined	144
Reel Door Interlock	135	Speed, Skipping	123
Reel Release Key	135	SPS	23
Reflective Spot	62	SPS Coding Sheet	23
Registers	19, 20	SPS Mnemonics	24
Register Key-Lights	111	Stacker Light	118
Register Lights	111	Stackers, 1402	10
Registration of Forms	163	Standard-Size Forms Chart	163
Removing the Platen	132	Start Key, 729, 7330	134
RPG (IBM 1401 Report Program Generator)	27	Start Key, 1401	114
Request/Enter Key-Light	129	Start Key, 1402	118
Reset Key, 729, 7330	135	Start Key, 1403	119
Reset Overlap	100	Start Punch Feed	79
Reset Overlap and Branch	101	Start Read Feed	78
Respond/Typeout Key-Light	129	Start Reset Key	114
Restart, 1403 with Print Storage	139	Start Time, Tape	152
Restart, 1403 Without Print Storage	139	Starting the System	136
Restart Procedures	138	Status Control Word	41
Restart, Punch Feed Read	138	Stop Brushes	124
Reversing a Ribbon, 1407	131	Stop Key, 1401	114
Rewind and Unload	61	Stop Key, 1402	118
Rewind Tape	61	Stop Key, 1403	119
Ribbon Changing, 1403	125	Stop Time, Tape	152
Ribbon Reverse Lever, 1407	131	Storage Address Dial Switches	111
Ribbon Shield	121	Storage Address Light	111
RH Tractor Vernier	121	Storage Layout Chart	19
Rule 1, Program Loading	164	Storage Light	109
Rule 2, Program Loading	165	Storage Print Out	113
Rules, Editing	41	Storage Scan	114
Rules of Division	75	Store A-Address Register	85
Rules of Multiplication	74	Store Address Register Feature	85
Run Mode	112	Store B-Address Register	85
		Stored Program	7, 19
		Stored Program Instructions	15
Scanning Storage	116	Subtract A-Address	31
Schematic of Instruction Loading	21	Subtract A- and B-Address	30
Seek	65	Summary, Timing Chart	148
Seek Disk	65	Suppress, Space	105
Select Light, 729, 7330	134	Symbolic Languages	23
Select Stacker	51	Symbolic Statements	23
Select Stacker and Branch	51	Sync Check Light	119
Sense Switch Indicators	87	Sync Points	117
Sense Switches	112	Systems Timings	149
Sense Switches Feature	87		
Sequence of Characters for Comparing	34	Tab Clear Key	130
Set Word Mark, A-Address	36	Tab Set Key	130
Set Word Mark, A- and B-Address	36	Tagging	84
Setup Operations, 51-Column Feed Feature	97	Tape Adapter Unit (TAU)	152
Seven-Bit Tape Coding	53	Tape Checking	56
Shift Interlock, 1403	123	Tape-Controlled Carriage	123
Sign, Arithmetic Operations	28	Tape-Density Lights	134
Sign Control for Addition	28	Tape Indicate On Light	134
Sign Control for Division	75	Tape Instructions	57
Sign Control for Multiplication	74	Tape Intermix	55
Sign Control for Subtraction	30	Tape I/O, Auxiliary Mode Switch	117
Sign Control Left	83	Tape I/O R/P, Auxiliary Mode Switch	117
Simultaneous Input-Output Operations	144	Tape Light	109
Single-Address Instructions	22	Tape Load Key	115
Single-Cycle Key	120	Tape Mark Character	60
Single-Cycle Non-Process	113	Tape Operations, Processing Overlap	98
Single-Cycle Process	112	Tape or Input-Output Busy, Processing Overlap	103
Single Record	65	Tape Processing Time	152
Skip and Blank Tape	61	Tape Select Switch	114
Skipping, 1403	11	Tape Unit Characteristics	56
Slow Brushes	124	Tape Units	55
Solid-State Circuitry	9	TAU (Tape Adapter Unit)	152
Source Program	23	Test High, Low, or Equal Compare	86
Space Bar, 1407	72	Thermal Interlock, 1403	123

Timing	140
Timing Chart, Summary	148
Timing, Input-Output Operations	140
Timings, Divide	150
Timings, Multiply	150, 151
Timings, Systems	149
Total Job Time	159
Tractor Slide Bar	121
Transport Light	118
True Add	28
Turning Off the System	136
Unequal Address Compare, 1405	69
Unload Key	135
Using Modulus Arithmetic	106
Using the Modify Address Instruction	107
Validity Checking	14
Validity Light	118
Variable Word Length	15
Vertical Print Adjustment	121
Weight, Paper	162
Width of Forms	161, 162
Word Mark Key, 1407	129
Word Marks	15
Word Separator Character	59, 60
Words	15

Write a Line	47
Write and Branch	47
Write and Punch	49
Write and Read	48
Write Binary Tape	93
Write Check	65, 67
Write Disk Check	67
Write Disk, Full Track	66
Write Disk, Full Track with Word Marks	68
Write Disk, Single Record	66
Write Disk, Single Record with Word Marks	68
Write on Console Printer	71
Write on Console Printer with Word Marks	72
Write, Punch, and Branch	50
Write, Read, and Branch	48
Write, Read, and Punch	50
Write, Read, Punch, and Branch	50
Write, Read Punch Feed	81
Write, Read Punch Feed and Branch	81
Write Tape	58
Write Tape in Overlap Mode	101
Write Tape Mark	60
Write Tape with Word Marks	59
Write Word Marks	47
Write Word Marks and Branch	48
Writing High-Density Tape in Overlap Mode	101
Wrong-Length Record, 1405	69
Zero and Add	30
Zero and Subtract, A-Address	31
Zero and Subtract, A- and B-Address	31
Zero Suppression, Editing	43
Zone Value, Increased Core Storage	77

IBM

**International Business Machines Corporation
Data Processing Division
112 East Post Road, White Plains, New York**