

# Climates: Architecture and the Planetary Imaginary

James Graham  
**Editor**

Caitlin Blanchfield  
**Managing Editor**

Alissa Anderson  
Jordan H. Carver  
Jacob Moore  
**Contributing Editors**

Columbia Books on  
Architecture and the City

Lars Müller Publishers

The Avery Review  
[www.averyreview.com](http://www.averyreview.com)

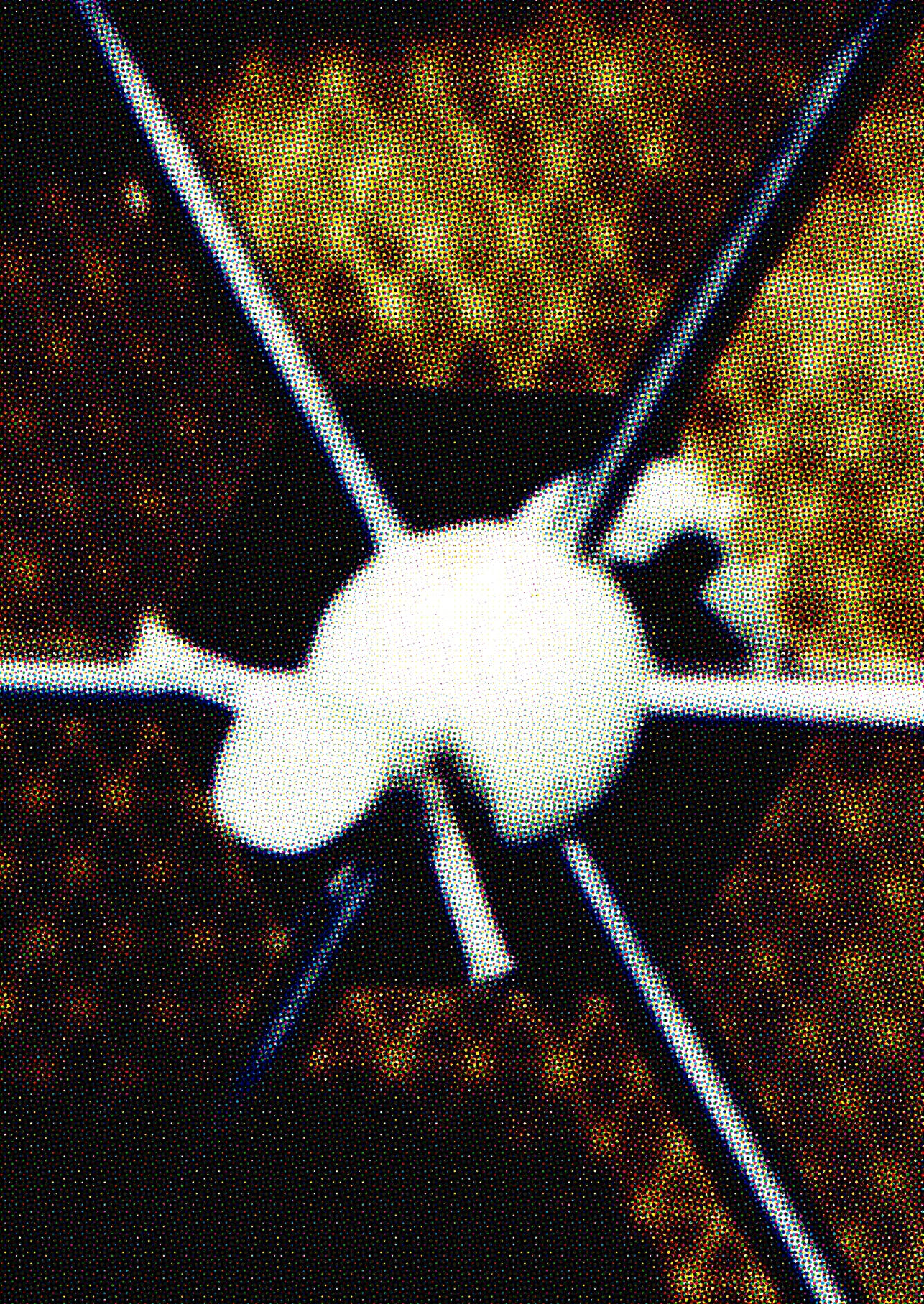

# Securing Adjustable Climate

FELICITY D. SCOTT



*Endcap View of Cylindrical Colony with Suspension Bridge*, Don Davis, 1975. Courtesy of NASA Ames Research Center.

On May 13, 1974, front page headlines in the *New York Times* read, “Proposal for Human Colonies in Space Is Hailed by Scientists as Feasible Now.”<sup>1</sup> The article was illustrated with a rather prosaic diagram modeled after eighteenth-century mathematician Joseph Louis Lagrange’s hypothesis on celestial mechanics. It identifies Lagrange Libration point 5 (or L5), a point of stable equilibrium between the sun, the earth and its moon, as an ideal site for the first space colony, since the colony could retain its position within this celestial orbit without having to accelerate. Walter Sullivan, a prominent science journalist, reported on an event convened three days earlier at Princeton University by physics professor Gerard K. O’Neill, a renowned high-energy particle physicist. Liberated not only from gravity and friction but also from inhospitable climates, material scarcity, “large scale governments,” and other Earthly threats, O’Neill’s space colonies were imagined to take the form of giant, rotating, man-made habitats (initially in cylindrical form) that would replicate, or so he insisted, the most beautiful parts of Earth, exemplified for him by Carmel Bay, California, along with the Grand Teton mountains in Wyoming, the island of Bermuda, and “attractive villages in Italy and Southern France.”<sup>2</sup> His space colonies were represented at this time by technical diagrams, supplemented by a powerful and distinctly neoliberal narrative. With an abundance of material goods, endless sunshine, “virtually unlimited”

1

Walter Sullivan, “Proposal for Human Colonies in Space Is Hailed by Scientists as Feasible Now,” *New York Times*, May 13, 1974, 1, 23.

2

Gerard K. O’Neill, “A-III. The Colonization of Space,” Appendix A, Proceedings of the Princeton Conference on the Colonization of Space, May 10, 1974, in *Space Manufacturing Facilities (Space Colonies)*, Proceedings of the Princeton/AIAA/NASA Conference, May 7–9, 1975, ed. Jerry Grey (New York: American Institute of Aeronautics and Astronautics, Inc., 1977), A7, A10. O’Neill speaks of their “independence from large-scale governments” on page A7 and likens them to “attractive villages in Italy and Southern France” on page A10.

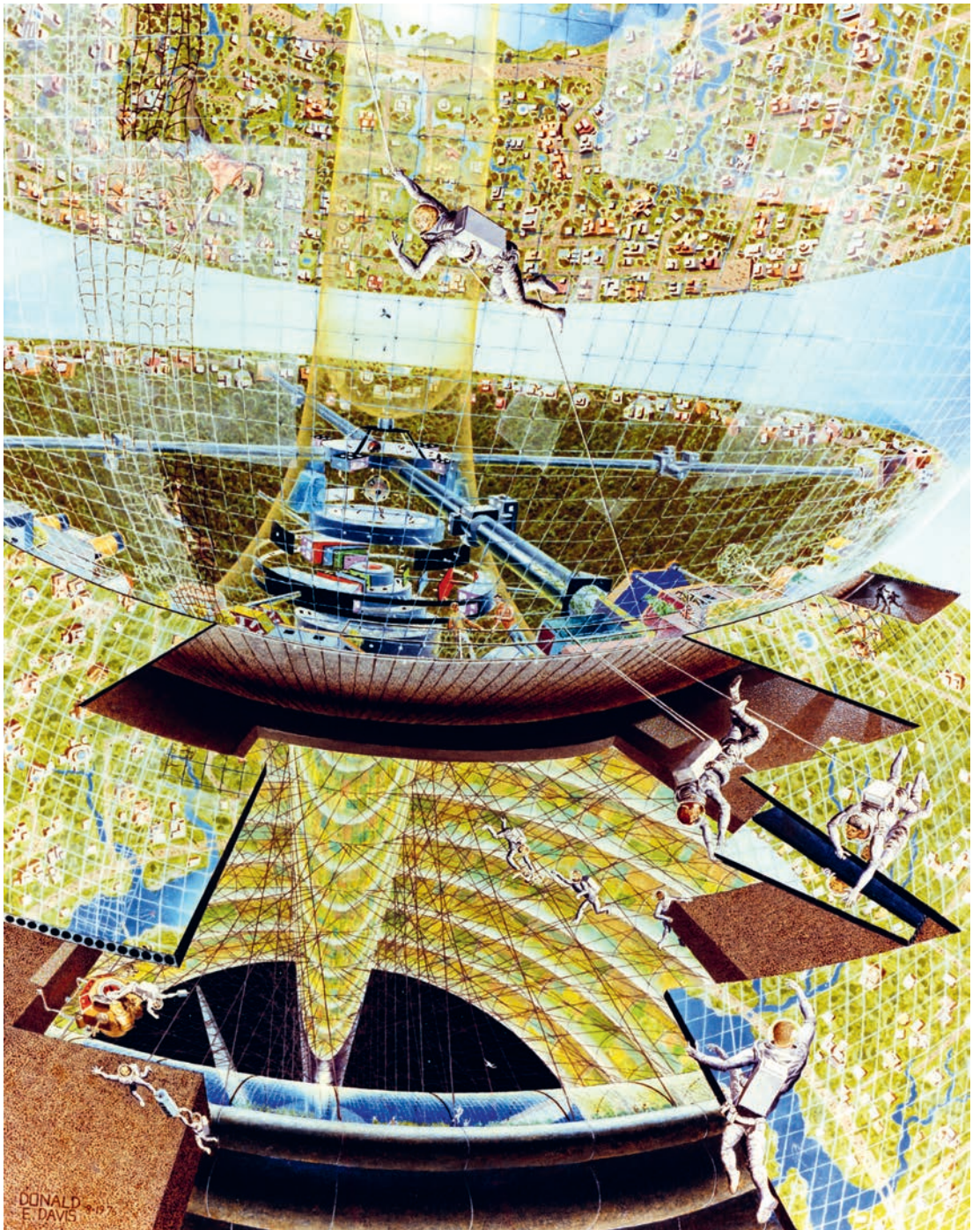

*Construction Crew at Work on Bernal Sphere Colony, Don Davis, 1976. Courtesy of NASA Ames Research Center.*

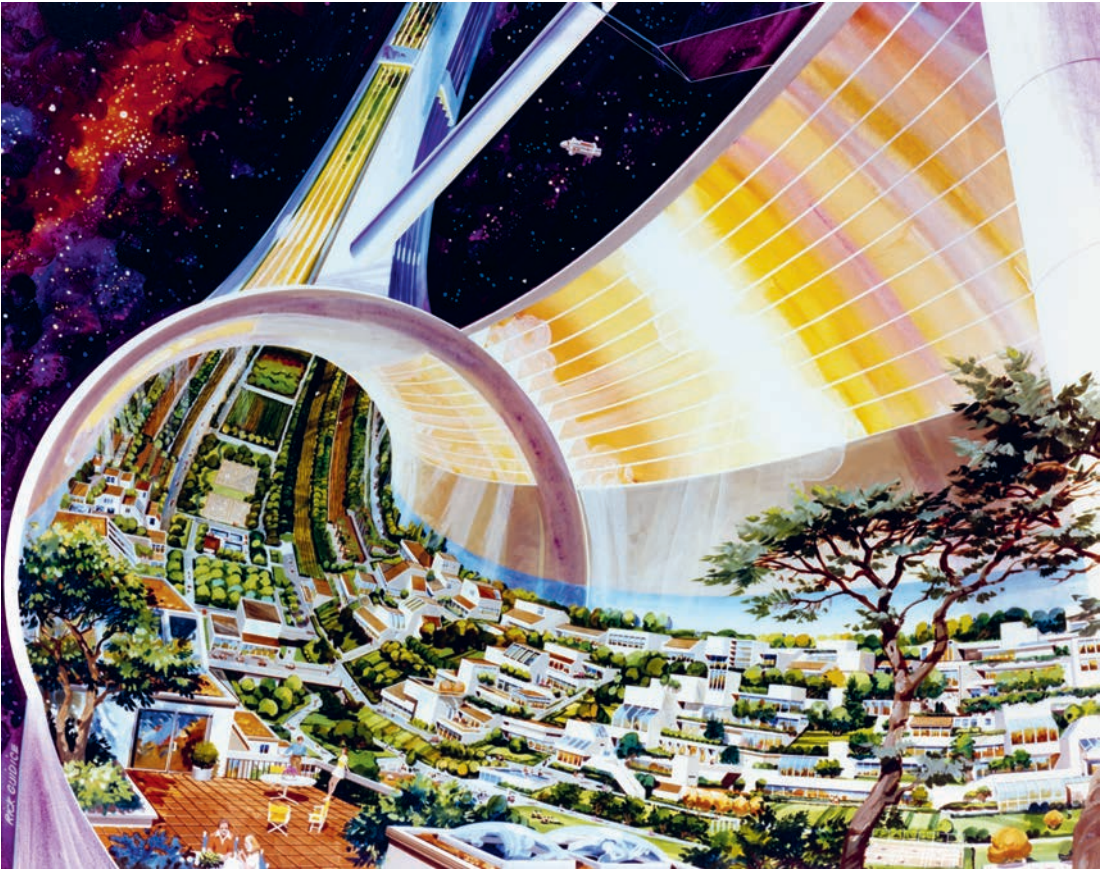

Cutaway View of Torus Space Colony, Rick Guidice, c. 1975. Courtesy of NASA Ames Research Center.

resources harvested from outer space, freedom to travel, and, as he repeatedly underscored, “independence from large-scale governments,” pioneering colonists were promised attractive, self-sufficient, profitable, Earth-like environments.<sup>3</sup> Yet, unlike Earth, there would be no unproductive workers, no pollution, no limits to energy consumption, no garden-destroying pests. Fresh strawberries would be available throughout the year.<sup>4</sup>

Confidently pitching science-fiction-like narratives as the most rational scientific solution to the world’s problems, O’Neill offered truly fantastic figures of emigration rates, population growth, and (through an avowedly “bootstrap” plot) the rapid self-replication of space communities. Starting with a small, higher-density Model 1 colony (soon to be called Island One and from which the others would be fabricated), he estimated that by 2074 “more than 90% of the human population could be living in space colonies” such as his Model 4.<sup>5</sup> Although not necessarily desirable, there would be room, he claimed, to expand the human population by a factor of twenty thousand. Here was an exponential growth curve speaking not to imminent doomsday, as with neo-Malthusian systems dynamics studies like Jay W. Forrester’s *World Dynamics* of 1971 and *The Limits to Growth*, published by the Club of Rome as an intervention to the UN’s 1972 Conference on the Human Environment in Stockholm.<sup>6</sup> O’Neill’s diagrams indicated Earth’s population decreasing as that in outer space spiraled upward on account of unlimited resources. With industry and populations relocated to

3

O’Neill, “A-III. The Colonization of Space,” A7.

4

O’Neill, “A-III. The Colonization of Space,” A10.

5

O’Neill, “A-III. The Colonization of Space,” A6–A7.

6

On this aspect of the Stockholm Conference, see Felicity D. Scott, *Outlaw Territories: Environments of Insecurity/ Architectures of Counterinsurgency* (Brooklyn: Zone Books, 2016).

outer space, as Sullivan reported, Earth would be left with “few permanent residents. It would be ‘a worldwide park, a beautiful place to visit for a vacation.’”<sup>7</sup>

As indicated in the *New York Times*, this rosy vision was haunted by a constellation of contemporary anxieties: Columbia University physicist professor Gerald Feinberg, Sullivan reported, “said that in a world threatened by nuclear devastation or catastrophic pollution effects, colonies in space would provide insurance for the continuity of the human race and other life forms.” Life itself, that is, was at stake. Feinberg, too, mobilized the Jeffersonian appeal to self-sufficiency and self-government, drawing analogies to the colonization of the Americas to suggest that space colonies would “tend to be independent” and “could provide a haven for dissidents and would offer the advantages of small, independent political units.”<sup>8</sup> Sullivan concluded by alluding to a lingering doubt: “Within the solar system, Dr. O’Neill pointed out, there is plenty of room for colonization ‘without shooting any Indians.’”<sup>9</sup> “In contrast to our experience with expanding civilizations on Earth,” O’Neill had explained at Princeton, distancing himself from the specter of colonial violence, “in space colonization there would be no destruction of indigenous primitive populations; nothing corresponding to the Indian wars of 19th century America.”<sup>10</sup> Space colonization was repeatedly and ambiguously likened to the European discovery of the New World and the ideology of manifest destiny associated with the nineteenth-century American frontier: at a moment when US expansion and economic growth seemed threatened by resource scarcity, environmental degradation, nuclear fallout, or political pressures both at home and from developing countries, including the oil-rich nations of OPEC, space colonization suggested continuity in US supremacy and pioneering know-how.

The *New York Times* coverage proved pivotal. O’Neill had struggled to gain support for his ideas in the preceding years, eventually gaining seed money for the 1974 event from Michael Phillips, president of the Point Foundation, the California agency through which Stewart Brand channeled the immense profits of his alternative lifestyle initiative, the *Whole Earth Catalog*. O’Neill’s space colony obsession began somewhat by chance in fall 1969 when, in the wake of the euphoria of the Apollo moon landing, and seeking to counter growing disenchantment with science and engineering among the country’s youth arising from the violence of the US-led war in Vietnam, he posed the question to his freshman physics students, “Is the surface of a planet really the right place for an expanding technological civilization?”<sup>11</sup> As detailed by W. Patrick McCray in *The Visioneers*, O’Neill became increasingly convinced by his findings, and increasingly frustrated by their rejection among the scientific community, finally gaining an audience when the popular magazine *Physics Today* published “The Colonization of Space” in September 1974.<sup>12</sup>

In addition to outlining technical and scientific details behind his evidently inflated claim that self-sufficient space colonies were achievable in the next few decades, O’Neill’s *Physics Today* article underscored that colonization held the promise of solving not only the US’s but the world’s major problems by offering an abundant clean energy supply, protection of the biosphere, the expansion of living space (*lebensraum*) and even equalizing living standards. Indeed, adding the question of security to that of scarcity, territory, and population, he claimed nothing less than world peace to be at stake.

7

O’Neill, “A-III. The Colonization of Space,” A7.

8

Gerald Feinberg cited in Sullivan, “Proposal for Human Colonies in Space Is Hailed by Scientists as Feasible Now,” 23.

9

Sullivan, “Proposal for Human Colonies in Space Is Hailed by Scientists as Feasible Now,” 1, 23. O’Neill expands on the bootstrap logic in “The Space Manufacturing Facility Concept,” in *Space Manufacturing Facilities (Space Colonies)*, 7–11.

10

O’Neill, “A-III. The Colonization of Space,” A11.

11

See, for instance, “Is the Surface of a Planet Really the Right Place for an Expanding Civilization?: Interviewing Gerard O’Neill,” in Stewart Brand, ed., *Space Colonies* (New York: Penguin Books, 1977), 22.

12

See W. Patrick McCray, *The Visioneers: How a Group of Elite Scientists Pursued Space Colonies, Nanotechnologies, and a Limitless Future* (Princeton, NJ: Princeton University Press, 2013); and Gerard O’Neill, “The Colonization of Space,” *Physics Today*, September 1974, 32–40.

Figure A-3 Possible Arrangement For The End Cap Of A Model 1 Space Colony

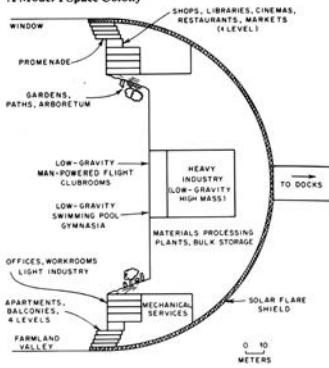

Possible Arrangement for the End Cap of a Model 1 Space Colony, c. 1974.

Figure A-4 Scale of 4-mile-diameter Model 4 Space Colony

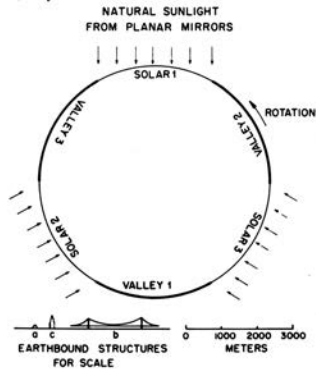

Diagram showing scale of a 4-mile-diameter Model 4 Space Colony, c. 1974.

Figure A-2 The "Model 1" Space Colony

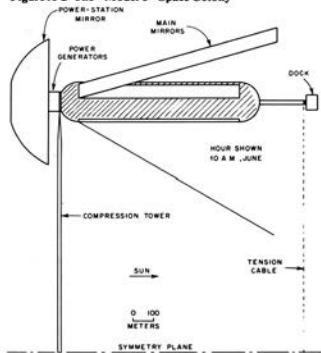

Diagram of the Model 1 Space Colony, c. 1974. Images from *Space Manufacturing Facilities (Space Colonies): Proceedings from the Princeton/AIAA/NASA Conference May 7-9, 1975.*

I hesitate somewhat to claim for space-colonization the ability to solve one other problem, one of the most agonizing of all: the pain and destruction caused by territorial wars. Cynics are sure that humanity will always choose savagery even when territorial pressures are much reduced ... Yet I am more hopeful; I believe that we have begun to learn a little bit in the past few decades. The history of the past 30 years suggests that warfare in the nuclear age is strongly, although not wholly, motivated by territorial conflicts; battles over limited, nonextendable pieces of land.<sup>13</sup>

13

O'Neill, "The Colonization of Space," 36.

It was powerful rhetoric. Picking up momentum from the *Times* article, and the popular reception of O'Neill's ideas in *Physics Today*, the US National Aeronautics and Space Administration (NASA), its funding then in decline in the wake of the Apollo missions and the winding down of Skylab, recognized an opportunity. NASA gave \$12,000 toward, and co-convened, a second, larger conference at Princeton in May 1975, the Conference on Space Manufacturing Facilities (Space Colonies). In addition to convening physicists from Princeton, Columbia, and MIT (as in the first event), it brought together experts from large corporations; the US government and military agencies; as well as from legal, diplomatic, social-scientific, cultural, and management realms.<sup>14</sup> Additionally, NASA contributed \$100,000 for the NASA/Ames-Stanford University Summer Study on Space Colonization that year and funded O'Neill's book-length manifesto, *The High Frontier: Human Colonies in Space* of 1977.<sup>15</sup> It also contributed to visual marketing. Hence, when on July 23, 1975, O'Neill testified about the benefits of space colonization to the US House of Representatives' Committee on Science and Technology, he arrived armed with a large model, seductive renderings by California artist Donald Davis and Frank Guidice of the NASA-Ames laboratory, and even a short film produced by NASA in association with the National Public Affairs Center for Television and Dolphin Productions, New York.

14

I have written elsewhere on the contribution of MoMA's Ludwig Glaeser to this event and the relation of O'Neill's work to the period's architecture more generally. See Felicity D. Scott, "Earthlike," forthcoming in *Grey Room*.

15

Gerard O'Neill, *The High Frontier: Human Colonies in Space* (New York: Morrow, 1977).

Wavering between the language of plenty and economic development and the threat of scarcity, insurrection, and war, and with characteristic rhetorical flair, O'Neill launched his congressional testimony at the nexus of "American know-how" and appeals to freedom, cast in distinctly neoliberal terms. The moon landing, he proposed, was better understood not as a scientific venture but as a "prospecting survey" for space colonization, much as a mining company might undertake. He ended by recalling that, on a recent trip to Alabama, he was greeted by a large group of young people waving placards and shouting not in protest but in an enthusiastic embrace of his new techno-scientific developments. As demonstrated in the beautiful renderings, space colonies would establish productive, profitable, isolated, normative, passive workforce communities living "in comfort, even in some luxury, within a large enclosed volume having a climate where flowers, trees, birds and animals could flourish."<sup>16</sup> As I argue elsewhere, drawing on De Witt Douglass Kilgore's *Astrofuturism*, O'Neill's promise of a lush, protected suburban lifestyle was code for racial segregation in America.<sup>17</sup> Here I want to try to refract this "promise" through a different lens, for the proclaimed "benefits" and the violent reshufflings implied by his space colonization enterprise were directed not only toward forces within the US, wherein they might serve to contain insurrection and dissent, but also globally. Indeed, at stake was their potential to help foster the country's dominant role in processes of economic globalization and in scripting the global management of environmental resources, the contours of which were then being articulated simultaneously through business and institutions like the United Nations and World Bank. Whether domestically or globally, within this shifting geopolitical landscape space colonies were to operate in the interest of corporate profit.

O'Neill told Congress that space colonies were key to the US's economic and resource security now that "both the oil-consuming nations and the underdeveloped third world are vulnerable to the threat of supply cutoff from the Middle East."<sup>18</sup> Promising to transmit solar satellite energy back to earth via giant microwave beams, US energy independence would be assured without the political backlash caused, domestically, by strip-mining and nuclear proliferation, and at a scale far beyond the Alaska pipeline. Given the scale of the marketplace for the primary product—energy—the payoff for investors would also be enormous. "We can put the Middle East out of business!" he recounted one of collaborators as having exclaimed.<sup>19</sup> Moreover, taking lessons from the development sector, he rehearsed the argument that what was good for the US was good for the world, claiming the US would be able to supply cheap energy to developing countries or even provide it as humanitarian aid, thereby overcoming growing hostility to the US as "exploiters of scarce resources."<sup>20</sup> Additionally, through promoting development, this energy supply would even reduce population growth in the global south and with it, as was widely feared at this moment, threats to political stability.

The fantasy that no one was exploited during processes of territorial expansion was an old trope, manifest in the European habit of imagining new worlds as empty territory, or in claims that modernization or religious conversion of indigenous populations was in their interest, as in the so-called civilizing mission. By the 1970s, development initiatives were increasingly forced to account for the rights of indigenous and formerly colonized peoples, and as with the period's developmental ideology, space colony enthusiasts thus turned to casting their work as humanitarian aid. Under the auspice of aid, poorer countries might be remade as a degraded image of the

16

Gerard K. O'Neill, testimony at *Future Space Programs 1975*, Hearings before the Subcommittee on Space Science and Applications of the Committee on Science and Technology, US House of Representatives," July 23, 1975, 170. The main body of O'Neill's testimony is reproduced in Brand, ed., *Space Colonies*, but that version elides the preamble, images, and question-and-answer period.

17

See Scott, "Earth-like."

18

O'Neill, testimony at *Future Space Programs 1975*, 129.

19

O'Neill, testimony at *Future Space Programs 1975*, 134.

20

O'Neill, testimony at *Future Space Programs 1975*, 135.



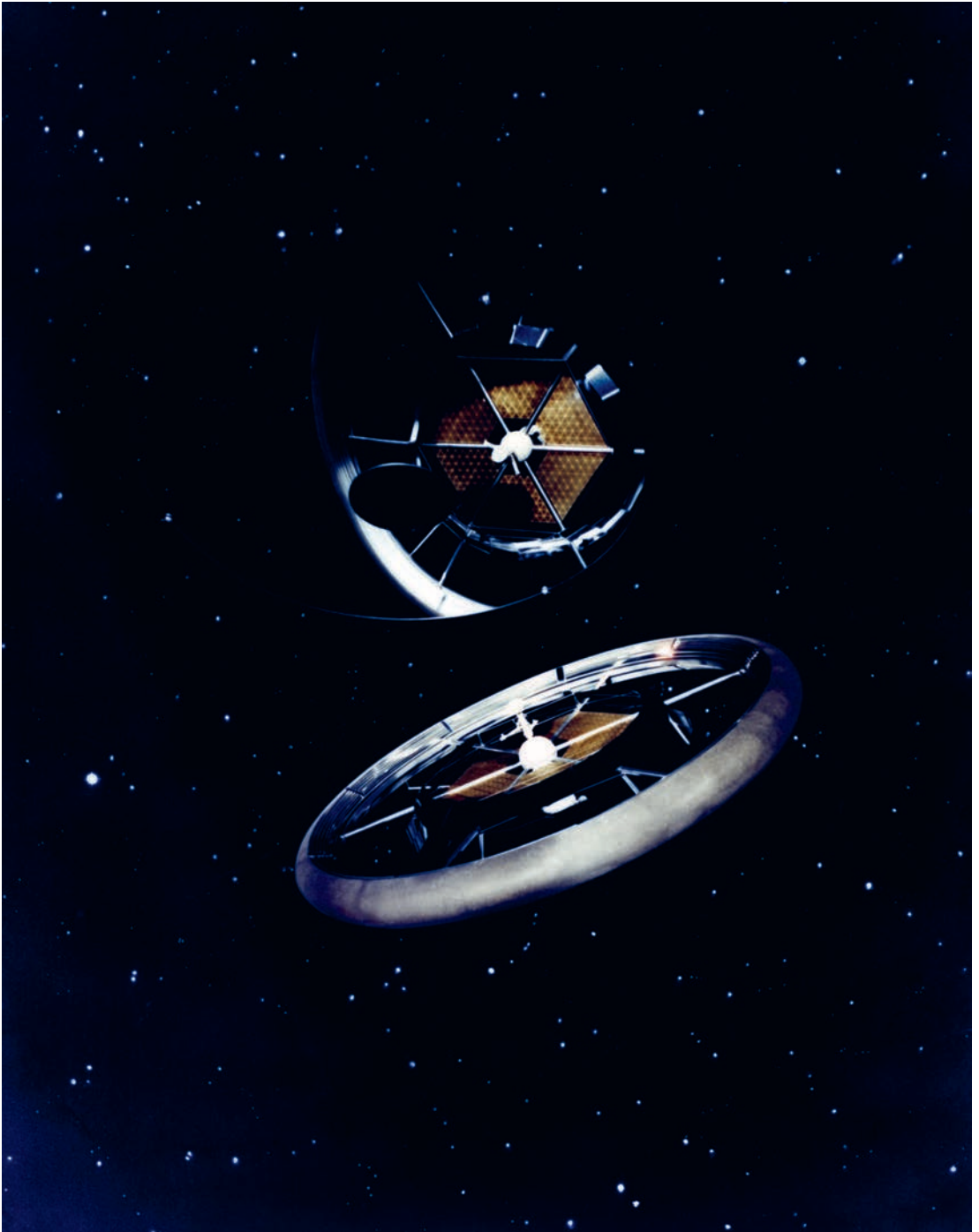

*Model of Torus Colony*, Don Davis, c. 1975. Courtesy of NASA Ames Research Center.

free world, replete with massive debt and burdened with technologies that, whether appropriate or not, ensured their ongoing dependence upon multinational corporations who were invariably the primary beneficiaries.

In a 1976 *Penthouse* interview, O'Neill again claimed space colonization for liberalism, calling it "a natural continuation of greater freedom, a greater amount of diversity and control over the environment."<sup>21</sup> Pointing to warlike tension resulting from the 1973 oil crisis and "pressure on land area as populations increase," as well as rising nuclear threats, he posited, "The unattractive alternatives seem to be a more tense situation in which nations are increasingly threatening each other in order to get the raw materials they need or some massive type of conflict that will result in a global dictatorship."<sup>22</sup> Space colonies, by contrast, offered a panacea, a way to "de-escalate that situation on Earth." There would be "much less reason for warlike activities than [between] countries on the Earth" not only on account of self-sufficiency but also since "their boundaries would be their own choice: if they don't like the neighboring colony, they could move somewhere else. If they don't like the land area they have, they could build more very easily without encroaching on anyone else's space."<sup>23</sup> The need for political negotiation, that is, would simply be eliminated. Yet within such a limitless, supposedly borderless place, space colonies would proliferate a new generation of border, even if freed from geographical constraints. In a world increasingly interconnected by communication and travel, the surfaces of space colonies sought to operate less like a border between sovereign states—which came with international protocols—than a police or even private security checkpoint that could regulate flows and movements of people more tactically, managing the distribution of populations following a "rational" metric of productivity and profit. As a counterpart to the ambiguous territorial logics of space colonies, many were left wondering if Earth would become a privileged site for those who could afford to live in nature, supported by energy from outer space, or if, rather, it would become the prison for those without the means, education, or work ethic to leave.

## OUTLAW AREA

It is not surprising that O'Neill first obtained support for his space colony initiative from the Point Foundation. An offshoot of the Portola Foundation, which published the *Whole Earth Catalog*, the Point Foundation was established in late 1971 by Stewart Brand and Richard Raymond, buoyed by enormous profits from the *Last Whole Earth Catalog*. Noting that it served as "an activist arm" for Brand, Andrew Kirk argues in *Counterculture Green*, "Point was an active experiment fostering the design science revolution."<sup>24</sup> That is, we might say, concomitant with Brand's avowed indebtedness to R. Buckminster Fuller, Point served as another mechanism through which to promote revolution not through politics but by design. In 1974 Brand launched *CoEvolution Quarterly* under the auspice of the Point Foundation, using it to sermonize on his rising fascination with space colonization. While O'Neill was in town for the summer study session at Stanford two years later, Brand and Phillips interviewed him in what they termed, trying to maintain the semblance of a countercultural edge, a "ghetto apartment in San Francisco." After discussing O'Neill's early struggles for support, the conversation turned to Point and the "famous \$600" grant. "So the *Whole Earth Catalog* is

21

"Penthouse Interview with Dr. Gerard K. O'Neill," *Penthouse* (August 1976), 175.

22

"Penthouse Interview with Dr. Gerard K. O'Neill," 176.

23

"Penthouse Interview with Dr. Gerard K. O'Neill," 176.

24

Andrew G. Kirk, *Counterculture Green: The Whole Earth Catalog and American Environmentalism* (Lawrence: University Press of Kansas, 2007), 119.

responsible for the colonization of space,” Brand blithely exclaimed, alluding to his savvy ability to script emergent cultural imaginaries. Phillips recalled his idea of putting the grant in Princeton’s name, which O’Neill concurred served very well in harnessing the university’s publicity apparatus. This strategy facilitated Sullivan’s article and the ensuing “media flash.”<sup>25</sup> Formerly a director of marketing and planning for Bank of America and vice president of the Bank of California, and with an economics degree from the University of Chicago, Phillips at this time effectively engineered a dramatic turn toward commercial entrepreneurship and free market ideals among hippies and the counterculture, the bible for which was his 1974 publication, *The Seven Laws of Money*. The seventh law, Kirk recalls, submits “you can never really receive money as a gift.”<sup>26</sup>

When Brand anthologized *CoEvolution Quarterly* entries on the subject as *Space Colonies*, he attributed his conversion “from mild interest in the Space Colonies to obsession” to O’Neill’s 1975 lecture at the World Future Society convocation in Washington, D.C., a few weeks before the professor’s congressional testimony.<sup>27</sup> Brand’s interest in the libertarian potentials of outer space in fact predated this encounter by a number of years. In January 1970, “The Outlaw Area” supplement to the *Whole Earth Catalog* included “The space out,” an inconspicuous note that, in retrospect, seems to have haunted Brand’s thinking throughout the decade. Citing British physicist Freeman Dyson, it reproduced part of a text from the December 1969 issue of *The Futurist*. The answer to the contemporary threat of permanent extinction of the human race on Earth following a nuclear holocaust, Dyson explained, was not found in colonizing planets like Mars—terraforming would not increase living space very much—but in “isolated city states floating in the void” and possibly attached to comets. “Above all they provide an open frontier, a place to hide and to disappear without trace, beyond the reach of snooping policemen and bureaucrats,” Dyson argued. “Space is huge enough so that somewhere in its vastness there will always be a place for rebels and outlaws ... Perhaps most important of all for man’s future, there will be groups of people setting out to find a place where they can be safe from prying eyes, free to experiment undisturbed with the creation of radically new types of human beings, surpassing us in mental capacities as we surpass the apes.”<sup>28</sup> Resonating with countercultural and libertarian ideals, and with the alternative lifestyle promoted in the *Whole Earth Catalog*, Dyson’s thesis was mirrored in Brand’s editorial for promoting “outlaw areas,” described as testing grounds beyond the domain of the law, or “state-of-the-art frontiers whose languages are still foreign to lawmakers.”<sup>29</sup> Despite international laws put in place following the launch of Sputnik, Brand listed space among “present outlaw areas.”

O’Neill’s presentation at the World Future Society, which so captured Brand’s attention, had a particularly Fulleresque tone. After refuting the premise that human activity, as with material and energy resources, be confined to Earth, O’Neill rejected the assumption that “any realistic solutions to our problems of food, population, energy, and materials must be based on a zero-sum game, in which no resources can be obtained by one nation or group without being taken from the other.”<sup>30</sup> It was such beliefs, he objected, that had “driven most observers to the conclusion that long-term peace and stability can only be reached by some kind of systematic global arrangement, with tight constraints to insure the sharing, equable or otherwise, of the limited resources available.” Repeatedly insisting that he was avoiding

25

O’Neill in “Is the Surface of a Planet Really the Right Place for an Expanding Civilization?” 25.

26

See Michael Phillips, *The Seven Laws of Money* (Menlo Park, CA: Word Wheel, 1974).

27

Stewart Brand, editorial note to Gerard O’Neill, “The High Frontier,” in *Space Colonies*, 8.

28

“The Space Out,” *Whole Earth Catalog* supplement, “The Outlaw Area” (January 1970): 48. The note is citing “Garbage Disposal Seen as Benefit of Space,” the *Futurist* (December 1969): 148, which in turn published excerpts from Freeman Dyson, “Human Consequences of the Exploration of Space,” *Bulletin of the Atomic Scientists* (September 1969): 8–15.

29

Stewart Brand, “Apocalypse Juggernaut, Hello,” *Whole Earth Catalog* supplement, “The Outlaw Area” (January 1970): 21. See Scott, *Outlaw Territories*.

30

O’Neill, “The High Frontier,” 8.

prophecy and speaking only of realistic possibilities, O'Neill posited that the frontier "can be exploited for all of humanity, and its ultimate extent is a land area many thousands of times that of the entire Earth."<sup>31</sup> Like Fuller's *World Game*, O'Neill rejected the political mandate of any such a "systematic global arrangement"—presumably a reference to the United Nations—in favor of technical solutions in line with the evolution of capitalism. Moreover, following what Brand called Fuller's "wealth sanction," not only would these solutions help overcome famine, war, and disease; like an earlier phase of colonization they promised enormous economic profit for nations who get there first.<sup>32</sup> "The human race," O'Neill proclaimed of the urgency to try, "stands now on the threshold of a new frontier, whose richness surpasses a thousand fold that of the new western world of five hundred years ago."<sup>33</sup> "It would be naïve to assume that its benefits will be initially shared equably among all of humankind," he acknowledged, reassuring potential investors of his intent, "The world has never worked that way."<sup>34</sup>

That Brand's conception of the new social formations possible within such outlaw areas remained premised on political exceptionality and militarism was evident in the scenarios he offered to readers of the *Whole Earth Catalog* in 1970. As Kirk recalls, Brand's initial concept for the use of the vast profits from the catalog was in fact to purchase vast tracts of land to realize "Mountain Fantasy" as a "permanent encampment" or "proving ground" to foster "social invention."<sup>35</sup> In 1975 Brand asked O'Neill what had come out of the second Princeton conference. O'Neill acknowledged "an interesting paper on Space Law," presumably that of Edward R. Finch, a permanent NGO representative to the UN Committee on the Peaceful Uses of Outer Space. The presentation, O'Neill recalled, brought three constraints to his attention:

First thing, it's got to be non-military. The second, that if anything interesting, new research, comes out of it, like information about the surface composition of the moon ... that it does have to be made available through the United Nations ... And last is that, at least in some nominal form, the community has got to be under the jurisdiction of the nation or group of nations which establishes it. You cannot, at least deliberately, send people out to be absolutely on their own.<sup>36</sup>

Finch, who preferred the term "space station" to "colony," was in fact also an advocate for commercialization of space research, later playing a major role in a business advocacy group, the National Space Society.<sup>37</sup> While Finch was largely concerned with reading international law to allow for the excavation of

31

O'Neill, "The High Frontier," 8.

32

See Thomas Albright, "The Environmentalists: The Whole Earth Catalog," *Rolling Stone*, December 13, 1969, 30–33.

33

O'Neill, "The High Frontier," 8.

34

O'Neill, "The High Frontier," 11.

35

Kirk, *Counterculture Green*, 120.

36

O'Neill in "Is the Surface of a Planet Really the Right Place for an Expanding Civilization?" 26.

37

See also Edward R. Finch and Amanda Lee Moore, *Astro-business: A Guide to Commerce and Law of Outer Space* (New York: Praeger, 1984); and Finch and Moore, "Outer Space Law and the Global Community," *The International Lawyer*, vol. 8, no. 4 (October 1974): 752–771.



Gerard K. O'Neill testifying before the Subcommittee on Space Science and Applications of the Committee on Science and Technology, United States House of Representatives, July 23, 1975. Photograph by Punky Crow from Stewart Brand, ed., *Space Colonies*.

materials on the moon, and other vital elements of O'Neill's vision, his outlining of the relevant UN resolutions and treatise made it evident that outer space was no longer beyond the law or the responsibilities attending national jurisdiction. Indeed, from *Resolution 1721* of 1961, which stated that international law and the UN charter applies to outer space, and that territory in outer space could not be subject to national appropriation, to the 1967 *Treaty on Principles Governing the Activities of States in the Exploration and Use of Outer Space, Including the Moon and Other Celestial Bodies*, and its updating, it was evident that prospective colonies fell firmly within the domain of international law. O'Neill's retort, resisting UN constraints, was that "technology and scientific advancement can be retarded if international law does not keep step with the progress of science," a notion of progress serving the interests of financial investors.<sup>38</sup>

When O'Neill testified to the US House of Representatives, he found himself again confronted with UN protocols, appearing after Peter Jankowitsch, Austrian ambassador to the United Nations and chairman of the thirty-seven-nation Committee on Peaceful Uses of Outer Space. He accounted for limits born of international law, not by embracing them but modifying his language to ensure that his scheme remained "realistic." By 1977, following repeated critiques of his proposal for strip-mining the moon, O'Neill decided to have a voice in such matters, establishing the Institute for Space Studies at Princeton, a nonprofit corporation that sought to become a recognized NGO by the UN. "We want to be able to make an input to the UN deliberations on such things as treatise about the Moon. We don't want things to be bargained away which we may very much want to be able to use later on," he explained to Brand. Citing a precedent in the troublesome Law of the Sea, he remarked, "Nobody's mining the sea because of the arguments."<sup>39</sup> Brand, by contrast, continued to seek a domain beyond the law. Introducing *Space Colonies*, he wrote, "for those who long for the harshest freedoms, who believe with Buckminster Fuller that a culture's creativity requires an Outlaw Area, Free Space becomes what the oceans have ceased to be—Outlaw Area too big and dilute for national control."<sup>40</sup> Fuller had long celebrated the maritime power born of mastering the high seas, regarding it not only as the key to European expansion but to technological invention. Aligning himself with Fuller, Brand, too, celebrated practices seeking to operate beyond national borders and outside the law as giving rise to spaces wherein one could try anything. Hence, although, as he noted—"the term 'Space Colony' has been expressly forbidden by the US State Department because of anti-colonial feelings around the world"—he would be sticking to it. Returning us to O'Neill's claim, Brand added, "It's more accurate. This time there's a difference in that no space natives are being colonized." Noting that some things "went well in previous colonizations," Brand concluded, "If we're lucky we may enact a parallel with what happened in Europe when America was being colonized. Intellectual ferment—new lands meant new possibilities; new possibilities meant new ideas."<sup>41</sup> When, in 1988, as founder of the Global Business Network, he interviewed Dyson for *Wired*, the elderly physicist refused Brand's technological determinism by invoking the presence of international laws, to which Brand responded, hopefully, "Won't overseas labs that don't care about such matters show up soon and do all the forbidden things?"<sup>42</sup>

Buoyed by the rhetoric of a better and more open future and no doubt visually seduced by the spectacular pastoral images produced to illustrate O'Neill's ideas, many within the counterculture and environmental movement

38

Edward R. Finch, "International Law and Outer Space Stations," in *Space Manufacturing Facilities (Space Colonies)*, 192.

39

Gerard O'Neill, in Gerard O'Neill, Stewart Brand, and Jane McClure, "Instead of Frictionless Elephants; Talking with Gerard O'Neill," in *Space Colonies*, 153.

40

Stewart Brand, "The Sky Starts at Your Feet," in *Space Colonies*, 6.

41

Brand, "The Sky Starts at Your Feet," 5. See Scott, *Outlaw Territories*.

42

"Freeman Dyson's Brain," accessible at <http://archive.wired.com/wired/archive/6.02/dyson.html>.

embraced *CoEvolution Quarterly's* celebration of space colonization as the next frontier. But, as recorded in the magazine following Brand's solicitation of commentary, many of his long-standing interlocutors expressed doubts and even an outright rejection of his new obsession. Some recognized the impossibility of simulating ideal landscapes: as John Holt suggested, the environment would be closer at best to the lobbies of Las Vegas hotels and luxury ocean liners, but more likely to military barracks and troopships; alternative technology celebrity Steve Baer offered an even more compelling image:

Once on board, in my mind's eye I don't see the landscape of Carmel by the Sea as Gerard O'Neill suggests ... Instead, I see acres of airconditioned Greyhound bus interior, glinting, slightly greasy railings, old rivet heads needing paint—I don't hear the surf at Carmel and smell the ocean—I hear piped music and smell chewing gum. I anticipate a continuous, vague low-key "airplane fear."<sup>43</sup>

43

John Holt and Steve Baer, commentary in *Space Colonies*, 64, 40.

Even more tellingly than rejecting the visual sales pitch, "biological designer" John Todd questioned the scientific claims upon which the agricultural and landscape vision was premised. Co-founder of the New Alchemy Institute, Todd was then working to complete the Ark on Prince Edward Island, an experimental "bioshelter" designed to simulate an almost closed ecosystem, and then the closest experimental test site to O'Neill's vision. Todd pointed out that ecological systems were far from simple to replicate in artificial environments, current understanding of whole systems being entirely "primitive" compared to nature's complexity. "When I read of schemes to create living spaces from scratch upon which human lives will be dependent for the air they breathe, for extrinsic protection from pathogens and for biopurification of wastes and food culture," he scoffed, "I begin to visualize a titanic-like folly born of an engineering world view." Citing statistics derived from Howard Odum's research, he suggested that Island One would be more appropriate to sustain forty rather than ten thousand people.

Beyond those refuting the aesthetic, scientific, and technical basis of O'Neill's arguments, others rightfully questioned its political underpinnings. Even neo-Malthusian Garrett Hardin, best known for his problematic diatribe "The Tragedy of the Commons," had doubts, recognizing that the Brave New World envisioned would likely be subject to totalitarian rule or that it would manifest as an expanded domain of hermetic religious cults. "The principle attraction of the Space Colony proposal is that it apparently permits us to escape the necessity of political control," he proffered, adding, "But, as we have just seen, this is only an apparent escape. In fact, because of the super-vulnerability of the spaceship to sabotage by tribal action, the most rigid political control would have to be instituted from the outset in the selection of the inhabitants and in their governance thereafter."<sup>44</sup> Indeed, by 1977 O'Neill was willing to acknowledge that, as with a sailing ship in open waters, the most effective governance structure for an isolated group might be far from democratic: "a dictatorship is what works," he noted in a later interview with Brand, since "there's nothing that produces conflict more than an ill-defined situation of authority."<sup>45</sup> With conflict comes the need for political negotiation within a democratic framework, hence dissensus had to be banished from the homogenous communities isolated in space. If space colonies were cast as a utopian multiplicity of potential domains, in which groups could maintain autonomy and diversity and assert their distinctions,

44

Garrett Hardin, commentary in *Space Colonies*, 54.

45

O'Neill in "Instead of Frictionless Elephants," 151.

the identitarian structure (which they cast as diversity—not within a colony but between them) and selection process implicitly evacuated the possibility of opening democratic forms of political space.

That O'Neill's politics remained aligned with economic paradigms driving colonialism and, more proximately, with the neocolonial ambitions of multinational corporations and neoliberal policies informing the US-led process of globalization was evident to others. Ridiculing Brand's suggestion that a democratic processes would prevail, as evident in Brand's claim that "voters will be interested enough to approve the requisite \$100 billion," Jan Bronstein insightfully responded by pointing to forces driving capitalism's long-standing expansionist ethos.

Since when do voters, or congress for that matter, appropriate money for those kinds of projects? They are pushed through by the folks that profit from huge government expenditures (enterprising capitalists and corporations) and passed by the people (government officials) who profit from the profit. Who stimulated European settlement of the Americas? The British East India Company, the Dutch East India Company, the gold seeking Spanish royalty. So realistically, the space colonies will get started when the Exxons of the future decide to monopolize this energy resource too.<sup>46</sup>

46

Jan Bronstein,  
commentary in  
*Space Colonies*, 35.

Novelist, environmental activist, and farmer Wendell Berry offered the most insightful dissent, pointing to many interconnected facets of O'Neill's elaborate and cynical apparatus. Mobilizing "every shibboleth of the cult of progress," he argued, O'Neill's vision was entirely conventional in its "lust for unrestrained expansion, its totalitarian concentrations of energy and wealth ... its exclusive reliance on technical and economic criteria ... its compulsive salesmanship." Here was a plan to strip-mine the moon presented as care for Earth's environment. "Anyone who has listened to the Army Corps of Engineers, the strip miners, the Defense Department, or any club of boosters will find all this dishearteningly familiar," he lamented of the "thug mentality of the technological specialist." With unchecked chauvinism and mindless of the neocolonial violence it implicitly condoned, O'Neill's public relations exercise was, as Berry put it, referring to the physicist as a "professional mind-boggler," "superbly attuned to the wishes of the corporation executives, bureaucrats, militarists, political operators, and scientific experts who are the chief beneficiaries of the forces that have produced our crisis."<sup>47</sup> What bothered him most, however, was that Brand had finally revealed himself to be an enemy masquerading as a friend.

47

Wendell Berry,  
commentary in  
*Space Colonies*, 36.

A closer look at Brand's activities seeking to mediate between the counter-culture and the US establishment suggests that such an ambiguous identity had long facilitated a less than progressive agenda under the language of social and technological innovation; his later founding of the Global Business Network was far from out of character.<sup>48</sup> Indeed, Brand's real savvy was in understanding that radical and reactionary agendas sometimes intersected or looked the same, often drawing from the same cultural and technical imaginary. Hence countercultural ideals were easily redirected toward cynical ends, as Brand demonstrated so well in taking countercultural celebrities to perform an "environment yes, politics no" worldview at the 1972 United Nations Conference on the Human Environment in Stockholm, or, as in Phillips's sponsoring of entrepreneurial attitudes toward money, the

48

See Scott, *Outlaw Territories*.

realization that hippies' interpersonal skills could be monetized. But such an ambivalence does not mean that distinct agendas should be neatly collapsed. It is equally important to remember that semantic and political revalencing can, in turn, operate in the other direction: critical voices might infiltrate and even produce an interruption or redirection of mainstream ideologies as well. Hence the importance of ironic practices or counter-discourses that seek not to follow technocratic ideals to their logical conclusions but to unpack their political underpinnings and inherent paradoxes, to render the apparatus through which they operate more legible.

I want to come back, in concluding, to the visual logics at play here. Unlike tabulated data and technical diagrams, and the perhaps more spectacular use of data visualization and satellite images that require expertise to interpret, NASA's space colony images appear to partake of a more archaic representational and media logic, to be an archaism with a contemporary function. Underscoring the role of visual media within the space colony initiative, Brand posited with typical entrepreneurial flair,

Now is the time for NASA to encourage people besides engineers to get into the act. The program needs administrators who are not afraid of excellent artists, novelists, poets, film-makers, historians, anthropologists, and such who can speak to the full vision of what's going on. And their voice needs to be a design voice, not just advisory. America (and Russia) were in Space for ten years before they bothered to get a photograph of Earth. That's pretty arid thinking.<sup>49</sup>

On account of his 1966 campaign, "Why haven't we seen a photograph of the whole Earth yet?" Brand, or so the story goes, was himself catalytic in NASA's release of Apollo mission images of Earth from outer space, images that catalyzed popular anxieties about limited resources and environmental devastation and were widely mobilized by a range of parties, from President Nixon

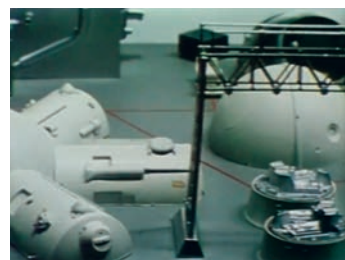
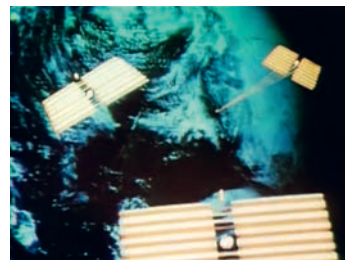
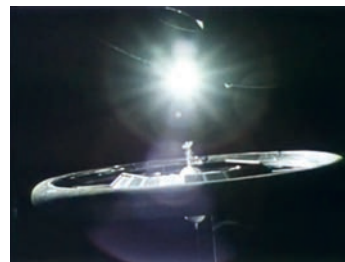

Stills from *Space Colonization*, NASA, 1975.

49

Brand, commentary in *Space Colonies*, 73.



to environmental activists and Brand himself. Space colonies, too, lent themselves to such an opportunity; seductive images were instrumental in sponsoring public support and economic investment. Cast as a vanguard, sometimes even thought to be avant-garde, futuristic visions could slip seamlessly from alternative to libertarian to neoliberal ideals and function all too effectively at the forefront of free-market capital. Resonating between an uncannily familiar environment and a spectacular otherness—a world quite literally turned inside out—renderings of O'Neill's visions, such as those produced in the mid-1970s, were powerful tools in garnering support across the social and cultural spectrum.<sup>50</sup>

While NASA's spectacular images of space colonization were put to work to mobilize support for O'Neill's purportedly "utopian" visions of a neoliberal future, with its claims to ensuring American-style freedom and diversity, power was shifting from technical know-how embodied in the agriculture and industrial machinery depicted in the NASA renderings, toward a less visible apparatus of information and management. This might help us understand why O'Neill was so disturbed by the Systems Dynamics model of Jay Forrester and the Club of Rome, which not only spoke to Earth's limited resources (in their case in the service of a racially inflected panic about population growth) but prioritized the benefits of computer-driven, social-science-informed management schemes as the techno-scientific infrastructure of new forms of governance, forms that in part displaced the priority of physicists and engineers. By 1976, O'Neill was willing to concede that the first colonies would "be much more like a Texas-tower oil rig, or a construction camp on the Alaska pipeline, or like Virginia City, Nevada, in about the year 1875" than the Carmel coastline or the South of France.<sup>51</sup> Compared to a future of exacerbated, post-planetary segregation and a return to an entirely privatized form of governance over colonial territories (think the East India Company), the violence inherent to techniques of power informing nineteenth- and early twentieth-century colonial and industrial paradigms might indeed have come to seem more limited in their reach.

In 1976 the US Congress, having lost interest in outer space exploration, amended the Space Act to allow NASA to engage in Earth science research and climate monitoring, in effect switching the agency's focus back to the planet with the mandate of expanding knowledge of Earth. At a moment marked by racially charged anxieties about population growth in the developing world, resource scarcity, and environmental catastrophe, such knowledge was critical to the maintenance of political power, whether in outer space or on Earth. Hence the importance of focusing not only on technical questions related to abstract formulations of human comfort (manifest in tables and diagrams) as well as environmental management and control, let alone the claims to

research under the rubric of complexity, and always and already operating at the nexus of the pragmatic and the utopian, were put to work as R&D for rethinking capitalist expansion. Fred Scharmen, "The High Frontier, the Megastructure, and the Big Dumb Object," paper presented at the 101st ACSA Annual Meeting, San Francisco, 2015. Available at <http://apps.acsa-arch.org/resources/proceedings/indexsearch.aspx?txtKeyword1=%22Scharmen%2C+Fred%22&ddField1=1>.

50

Fred Scharmen has offered a compelling archaeology of the visual culture informing O'Neill's space colony designs, from science fiction novels dating back to the 1950s and the research of Wernher von Braun, as well as films such as Stanley Kubrick and Arthur C. Clarke's *2001: A Space Odyssey* of 1968, to the phenomenon of architectural megastructures, which enjoyed an enhanced visibility on account of the 1967 Expo in Montreal. Unlike many other visions of occupying outer space, he notes, O'Neill saw space colonies not as rooms in space but as new ground upon which to erect a new architecture. That architecture was not entirely new by 1974. The environments in the NASA film *Space Colonization* certainly resonate with Moshe Safdie's *Habitat* in Montreal in its aesthetics of a modular diversity, with any last vestige of irony or counter-conduct long discarded in favor of an efficient, flexible, architectural machine. Here was a vision in which certain trajectories of experimental practice, those engaging scientific and technical

51

Gerard O'Neill, commentary in *Space Colonies*, 70. An editorial note explains that the text is derived from "remarks before the Senate Subcommittee on Aerospace Technology and National Needs on January 19, 1976, and his keynote address at the annual national convention of the American Institute of Aeronautics and Astronautics in Washington, D.C., on January 30, 1976."

bucolic earthlike environments that were the subject of visual representation. At stake was intervening within emergent techniques of power and hierarchical systems of global governance that were being instituted by US-driven neoliberal economic paradigms, under the rubric of technocratic forms of management and exemplified in the UN's development decade. When confronted by the seductive NASA renderings, the question is thus not what a space colony environment looked like, or even how pleasant its idealized climates might be, but how we might read the political and economic agendas they served to advance, agendas embodied within and beneath their spectacular surfaces. Such logics are reappearing in different form today in the haunting images depicting the waning of earthly beauty and stranded polar bears for NASA's current Global Climate Change initiative. All such images, and their mobilization, speak to the political nature of the period's rising interest in climate and environment as it has developed over the last five decades; they remind us that it was not natural processes (or even nature's relation to humans as a species) that was at stake so much as how questions of climate, nature, weather, and resources were framed as socioeconomic and political concerns, and hence participated in what Foucault termed "the calculated management of life."<sup>52</sup>

52

Michel Foucault, "Right of Death and Power over Life," in *The History of Sexuality: An Introduction*, trans. Robert Hurley (New York: Random House, 1990), 139–140.



**Climates: Architecture and  
the Planetary Imaginary**

**Columbia Books on  
Architecture and the City**

An imprint of the Graduate  
School of Architecture,  
Planning and Preservation  
Columbia University  
407 Avery Hall  
1172 Amsterdam Avenue  
New York, NY 10027  
[arch.columbia.edu/books](http://arch.columbia.edu/books)

**The Avery Review**

A digital periodical of critical  
essays on architecture  
[www.averyreview.com](http://www.averyreview.com)

**Lars Müller Publishers**

Zurich, Switzerland  
[www.lars-mueller-publishers.com](http://www.lars-mueller-publishers.com)

© 2016 Lars Müller Publishers  
and the Trustees of Columbia  
University in the City of New York  
Essays © the authors  
All rights reserved

ISBN 978-3-03778-494-5

Printed in Germany

No part of this book may be used  
or reproduced in any manner with-  
out the written permission of the  
publisher, except in the context of  
reviews. Every reasonable attempt has  
been made to identify the owners of  
copyright. Errors or omissions will be  
corrected in subsequent editions.

This book has been produced  
through the Office of the Dean,  
Amale Andraos and the Office of  
Publications at Columbia University  
GSAPP.

**Director of Publications**

James Graham

**Managing Editor**

Caitlin Blanchfield

**Associate Editor**

Alissa Anderson

**Copyeditor**

Ellen Tarlin

**Designed by**

Neil Donnelly  
Sean Yendrys

**Printing and Binding**

Kösel, Altusried-Krugzell, Germany

**Paper**

Munken Polar  
170 g/m<sup>2</sup>, 150 g/m<sup>2</sup>, 130 g/m<sup>2</sup>,  
120 g/m<sup>2</sup>, 100 g/m<sup>2</sup>, 80 g/m<sup>2</sup>

Avery Review website and  
identity designed by Eric Hu,  
Nothing in Common

**Library of Congress Cataloging-  
in-Publication Data**

Title: *Climates : architecture and  
the planetary imaginary* / edited  
by James Graham with Caitlin  
Blanchfield, Alissa Anderson, Jordan  
Carver, and Jacob Moore.

Description: New York : Columbia  
Books on Architecture and the City,  
2016. |

Includes bibliographical references  
and index.

Identifiers: LCCN 2016015773 |  
ISBN 9783037784945 (alk. paper)

Subjects: LCSH: Architecture and  
climate.

Classification: LCC NA2541 .C544  
2016 | DDC 720/.47—dc23

LC record available at [https://lccn.  
loc.gov/2016015773](https://lccn.loc.gov/2016015773)