



MacBook Pro

User's Guide

Includes setup, expansion,
and troubleshooting
information for your
MacBook Pro computer

 Apple Computer, Inc.

©2006 Apple Computer, Inc. All rights reserved.

Under the copyright laws, this manual may not be copied, in whole or in part, without the written consent of Apple.

Every effort has been made to ensure that the information in this manual is accurate. Apple is not responsible for printing or clerical errors.

Apple

1 Infinite Loop
Cupertino, CA 95014-2084
408-996-1010
www.apple.com

Apple, the Apple logo, AirPort, AppleTalk, Final Cut Pro, FireWire, iCal, iDVD, iLife, iMovie, iPhoto, iPod, iTunes, Mac, Macintosh, and Mac OS are trademarks of Apple Computer, Inc., registered in the U.S. and other countries.

AirPort Express, Exposé, FileVault, Finder, the FireWire logo, iSight, MacBook, Safari, Spotlight, SuperDrive, Tiger, and Xcode are trademarks of Apple Computer, Inc. AppleCare, Apple Store, and iTunes Music Store are service marks of Apple Computer, Inc., registered in the U.S. and other countries.

.Mac is a service mark of Apple Computer, Inc.

ENERGY STAR® is a U.S. registered trademark.

The Bluetooth® word mark and logos are owned by the Bluetooth SIG, Inc. and any use of such marks by Apple Computer, Inc. is under license.

Intel and Intel Core are trademarks or registered trademarks of Intel Corporation or its subsidiaries in the United States and other countries.

Other company and product names mentioned herein are trademarks of their respective companies. Mention of third-party products is for informational purposes only and constitutes neither an endorsement nor a recommendation. Apple assumes no responsibility with regard to the performance or use of these products.

The product described in this manual incorporates copyright protection technology that is protected by method claims of certain U.S. patents and other intellectual property rights owned by Macrovision Corporation and other rights owners. Use of this copyright protection technology must be authorized by Macrovision Corporation and is intended for home and other limited viewing uses only unless otherwise authorized by Macrovision Corporation. Reverse engineering or disassembly is prohibited.

Apparatus Claims of U.S. Patent Nos. 4,631,603, 4,577,216, 4,819,098 and 4,907,093 licensed for limited viewing uses only.

Simultaneously published in the United States and Canada.

Contents

7 Chapter 1: Getting Started

- 8 Setting Up Your MacBook Pro
- 16 Basic Features of Your MacBook Pro
- 18 Keyboard Features of Your MacBook Pro
- 20 Additional Features of Your MacBook Pro
- 22 Putting Your MacBook Pro to Sleep or Shutting It Down
- 24 Calibrating Your Battery
- 25 Getting More Information

27 Chapter 2: Getting to Know Your MacBook Pro

- 28 Adjusting Your Display
- 30 Using Your Power Adapter
- 31 Using the Trackpad
- 33 Using the Keyboard
- 34 Using a Mouse
- 35 Using the Apple Remote and Front Row
- 39 Using the Built-in iSight Camera
- 42 Getting Answers Using Mac Help

- 44 Learning About Mac OS X
- 45 Customizing Your Desktop and Setting Your Preferences
- 46 Using Applications
- 47 When an Application Does Not Respond
- 47 Keeping Your Software Up to Date
- 48 Connecting to a Printer
- 49 Playing a CD and Connecting Headphones
- 50 Connecting a Camera or Other FireWire or USB Device
- 50 Transferring Files to Another Computer

- 53 **Chapter 3: Using Your MacBook Pro**
- 54 Using Universal Serial Bus Devices
- 57 Connecting with FireWire
- 61 Using ExpressCards
- 62 How AirPort Provides Wireless Internet Access
- 64 Using Bluetooth Wireless Technology
- 66 Connecting with Ethernet
- 67 Using External Video Support
- 71 Connecting Speakers and Other Audio Devices
- 72 Using Your SuperDrive
- 76 Understanding Sudden Motion Sensor Technology
- 77 Using Your Battery
- 81 Securing Your MacBook Pro

- 83 **Chapter 4: Adding Memory to Your MacBook Pro**
- 84 Installing Additional Memory
- 91 Making Sure Your MacBook Pro Recognizes the New Memory

- 93 **Chapter 5: Troubleshooting**
- 94 Problems That Prevent You From Using Your Computer
- 96 Other Problems
- 99 Reinstalling the Software That Came With Your Computer
- 101 Using Apple Hardware Test
- 102 Installing Xcode Tools
- 102 Locating Your Product Serial Number

- 103 **Appendix A: Specifications**

- 105 **Appendix B: Safety, Use, and Care Information**
- 105 Understanding General Safety Instructions
- 106 Setting Up Your MacBook Pro and Power Adapter
- 107 Using Your MacBook Pro
- 109 Avoiding Hearing Damage
- 111 Understanding Ergonomics
- 113 Apple and the Environment

- 115 **Appendix C: Connecting to the Internet**
- 117 Gathering the Information You Need

- 119 Entering Your Information
- 121 Troubleshooting Your Connection
- 125 [Appendix D: Top Ten Questions](#)
- 131 Communications Regulation Information
- 135 [Index](#)

Getting Started

1

Your MacBook Pro includes the following components:

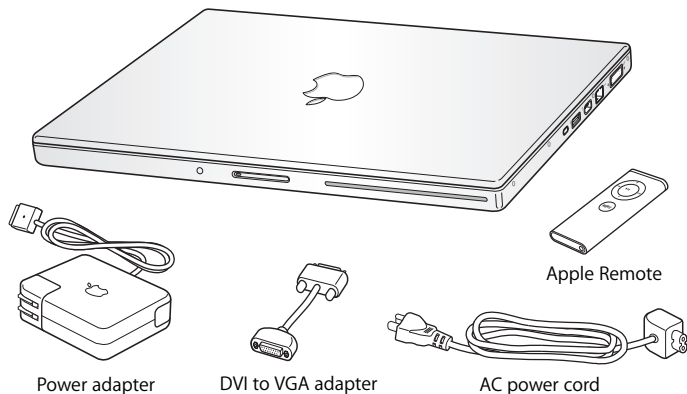

Important: Read all the installation instructions and safety information (see “Safety, Use, and Care Information” on page 105) carefully before you plug your computer into a power outlet.

Setting Up Your MacBook Pro

Your MacBook Pro is designed so that you can set it up quickly and start using it right away. The following pages take you through the setup process, including these tasks:

- Plugging in the power adapter
- Connecting the cables
- Turning on your MacBook Pro
- Configuring a user account and other settings using Setup Assistant

Step 1: Plug In the Power Adapter

If there is protective film around the power adapter, remove it before setting up your MacBook Pro.

- Insert the AC plug of your power adapter into an outlet and the power adapter plug into the MacBook Pro power adapter port. As you get close to the port, you will feel a magnet, which helps draw and guide the power adapter plug in.

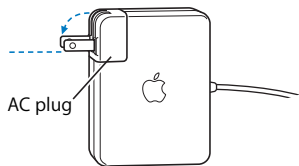

Warning: Make sure the AC plug is fully inserted into the power adapter and the electrical prongs on your AC plug are in their completely extended position before you plug the adapter into the power outlet.

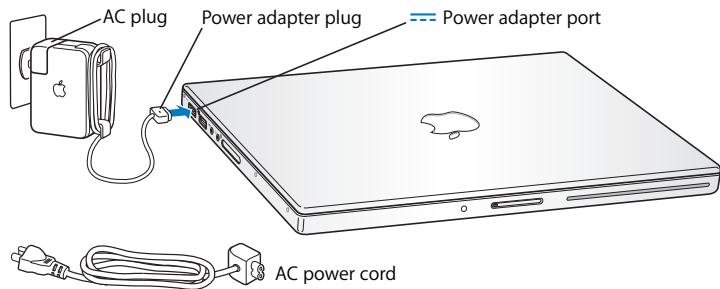

To extend the reach of your power adapter, you can attach the AC power cord. First, pull up on the AC plug to remove it from the adapter, and then attach the included AC power cord to the adapter. Plug the other end into a power outlet. For an illustration, see page 30.

Step 2: Connect Your Cables

Next, for an Internet connection, connect your MacBook Pro to a DSL modem, cable modem, external modem, or Ethernet network. If you're connecting to a wireless AirPort Extreme network, you don't need cables.

For information about types of connections, see Appendix C, "Connecting to the Internet," on page 115.

Note: Using a dial-up connection requires the external Apple USB Modem, available for purchase from the online Apple Store at www.apple.com/store or from an Apple Authorized Reseller. Plug the Apple USB Modem into a USB port on the MacBook Pro, and then connect a phone cord (not included) from the modem into a phone wall jack.

To connect to a DSL or cable modem or an Ethernet network:

- Connect the cable to your DSL or cable modem as shown in the modem instructions, or connect the Ethernet cable to the Ethernet hub or outlet. Then connect the other end of the cable to the computer's Ethernet (↔) port.

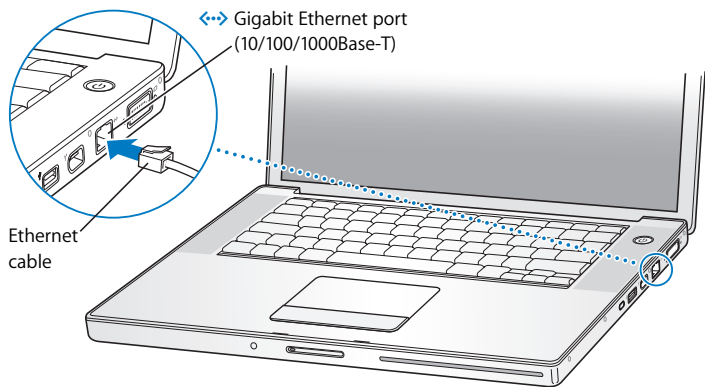

To connect wirelessly using AirPort:

- 1 Turn AirPort on, if necessary, by choosing “Turn AirPort on” from the AirPort (📶) status menu in the menu bar. AirPort detects available wireless networks.

2 Choose a network from the AirPort (📶) status menu.

Step 3: Turn On Your MacBook Pro

1 To turn on the MacBook Pro, press the power (⏻) button briefly (up to 1 second).

Do not continue to hold down or press the power button after the startup tone or you might cause the computer to shut down again.

When you turn on the computer, you should see the sleep indicator light turn on (and stay on), and you should hear a tone.

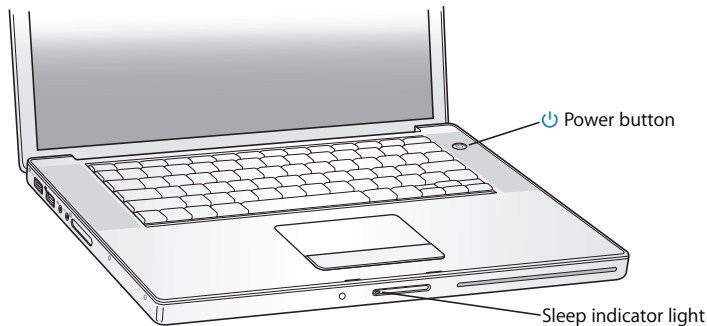

It takes the MacBook Pro a few moments to start up. After it starts up, the sleep indicator light turns off, and Setup Assistant opens automatically.

- 2 Use your MacBook Pro trackpad to select and move items on the screen, just like you use a mouse with a desktop computer.
- To move the arrow pointer on the screen, slide your finger across the trackpad.

Important: Use only one finger on the trackpad to move the pointer. The trackpad is designed to allow scrolling when you use two fingers and the scrolling feature is turned on by default. See “Using the Trackpad” on page 31 for more information.

- Use the trackpad button to select, click, or double-click items on the screen.

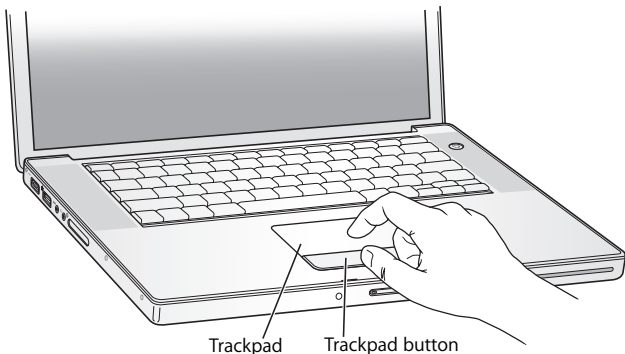

Problems Turning On the Computer?

Nothing happens when you press the power (⏻) button.

- The battery might be drained. Make sure that you plugged the power adapter firmly into both the computer and a power source. The power adapter plug should light when you plug it into the computer.
- If the computer still doesn't start up, see "Problems That Prevent You From Using Your Computer" on page 94.

You see a picture of a disk or a folder with a blinking question mark.

This icon usually means that the computer can't find the system software on the hard disk or any disks attached to the computer. Disconnect all external peripherals and try restarting. Hold down the power (⏻) button for 8 to 10 seconds until the computer turns off. Then press the power button again. If the problem persists, you might need to reinstall the system software. See "Reinstalling the Software That Came With Your Computer" on page 99.

Step 4: Configuring With Setup Assistant

The first time you turn on your computer, Setup Assistant starts. Setup Assistant helps you enter your Internet and email information and set up a user account on your computer.

If you already have a Mac, Setup Assistant can help you automatically transfer files, applications, and other information from your previous Mac to your new MacBook Pro.

To transfer information, make sure:

- Your other Mac has built-in FireWire and supports FireWire Target Disk Mode
- Your other Mac has Mac OS X v10.1 or later installed
- You have a standard 6-pin to 6-pin FireWire cable

Setup Assistant takes you through the process of transferring your information—just follow the onscreen instructions. Transferring information to your MacBook Pro does not affect the information on your other Mac. (If you set up partitions on the new MacBook Pro, all information from the other Mac will be transferred to one partition.)

Using Setup Assistant, you can transfer:

- User accounts, including preferences and email.
- Network settings, so your new MacBook Pro is automatically set up to work with the same network settings as your other Mac.
- Files and folders on the hard disk and partitions. This gives you easy access to the files and folders you used on your old Mac.
- The Applications folder, so most of the applications you used on your other Mac are now on your new MacBook Pro. (You may need to reinstall some of the applications you transfer.)

Important: Use caution when you transfer applications so that you don't overwrite later versions of the applications already installed on your MacBook Pro.

If you don't intend to keep or use your other Mac, it's best to deauthorize it from playing music, videos, or audiobooks that you've purchased from the iTunes Music Store. Deauthorizing a computer prevents any songs, videos, or audiobooks you've purchased from being played by someone else and frees up another authorization for use (you can have only five authorized computers at a time for an iTunes account).

If you don't use Setup Assistant to transfer information when you first start up your computer, you can do it later using Migration Assistant. Go to the Applications folder, open Utilities, and double-click Migration Assistant.

Note: If you used Setup Assistant to transfer information from an older Macintosh and you want to use Migration Assistant to transfer information from it again, make sure FileVault is turned off on the older Macintosh. To turn off FileVault, open the Security pane of System Preferences and click Turn Off FileVault. Follow the onscreen instructions.

Setup Assistant can also take you through the process of setting up your computer to connect to the Internet. For home users, Internet access requires an account with an Internet service provider (ISP). Fees may apply. If you already have an Internet account, see Appendix C, "Connecting to the Internet," on page 115 for information you'll need to enter.

Congratulations, you're up and running!

Basic Features of Your MacBook Pro

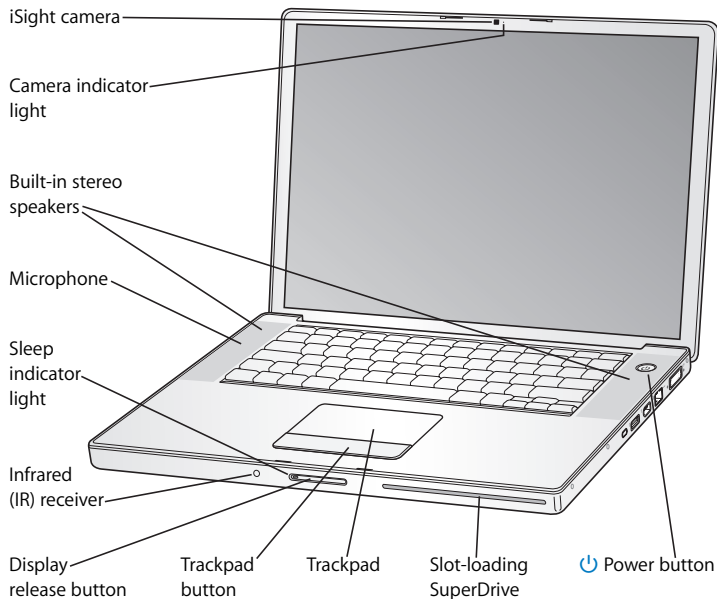

Built-in iSight camera and camera indicator light

Videoconference with others using the included iChat AV application. The green camera indicator light illuminates when the video camera is capturing and displaying video.

Built-in stereo speakers

Listen to music, movies, games, and other multimedia files.

Microphone (built in under the left speaker grille)

Use for videoconferencing with iChat AV and to record sounds directly on your hard disk.

Sleep indicator light

Pulsates when the MacBook Pro is in sleep mode. The white light glows steadily for a short time when you start up and shut down your MacBook Pro or when the display goes dark to save energy.

Built-in infrared (IR) receiver

Use your Apple Remote and the built-in IR receiver to control your digital content from a distance.

Display release button

Push to release your display and open your MacBook Pro.

Trackpad

Move the pointer on the MacBook Pro display with one finger on the trackpad; scroll with two fingers on the trackpad.

Slot-loading SuperDrive

Optical drive that reads and writes to CDs and DVDs.

**Power button**

Turn your MacBook Pro on and off or put it to sleep.

Keyboard Features of Your MacBook Pro

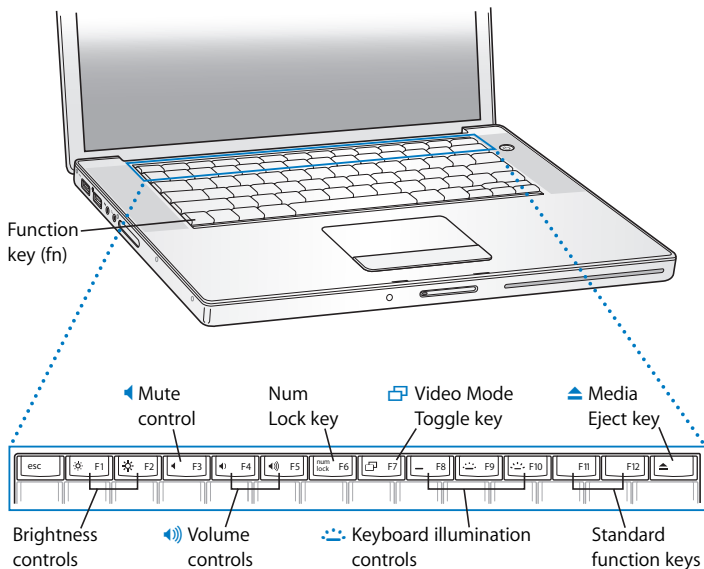

Function (Fn) key

Press and hold to activate customized actions assigned to the function keys (F1 to F12). To learn how to customize function keys, choose Help > Mac Help and search for “function keys.”

**Brightness controls**

Increase or decrease the brightness of your MacBook Pro display.

**Mute control**

Mute the volume of the sound coming from the built-in speakers and headphone port.

**Volume controls**

Increase or decrease the volume of the sound coming from the speakers and headphone port.

Num Lock key

Activate the numeric keypad embedded in the MacBook Pro keyboard. When the numeric keypad is activated, a green light glows on the key.

**Video Mode Toggle key**

Switch between dual-display mode (extending your desktop across the built-in and an external display) and video-mirroring mode (presenting the same information on both the built-in and an external display).

**Keyboard illumination controls**

Increase (⌘+F5), decrease (⌘+F6), or turn off (⌘+F7) the brightness of your keyboard illumination.

F11, F12

F11 is preset to open Exposé and F12 opens Dashboard.

**Media Eject key**

Press and hold this key to eject a disc.

Additional Features of Your MacBook Pro

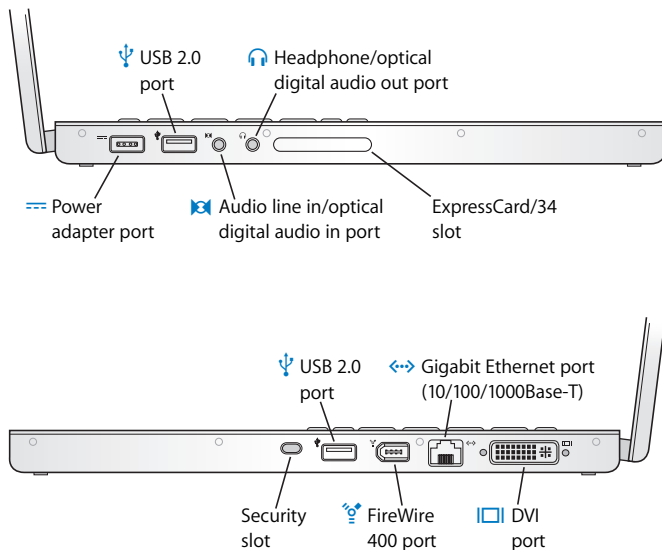

**Power adapter port**

Plug in the included power adapter to recharge your MacBook Pro battery.

**Two Hi-Speed USB 2.0 (Universal Serial Bus) ports**

Connect equipment to your MacBook Pro, such as iPods, printers, digital cameras, modems, and more. (Compatible with standard USB devices.)

**Audio line in/optical digital audio in port**

Connect your MacBook Pro to a line-level microphone or digital audio equipment.

**Headphone/optical digital audio out port**

Connect external speakers, headphones, or digital audio equipment.

ExpressCard/34 slot

Expand the capabilities of your MacBook Pro. Accepts 34mm ExpressCards.

Security slot

Protect your MacBook Pro by connecting a security cable (sold separately).

**FireWire 400 port**

Connect high-speed external devices, such as digital video cameras and external storage devices. You can connect a standard 6-pin FireWire device directly to the FireWire 400 port.

**Gigabit Ethernet port (10/100/1000Base-T)**

Connect to a high-speed Ethernet network or connect to another computer and transfer files. The Ethernet port's autosensing feature detects other Ethernet devices and doesn't require an Ethernet crossover cable in order to connect.

**DVI (external display) port**

Connect to an external display or projection device that uses a DVI connector, or use the included DVI to VGA adapter to connect a VGA monitor.

For more information about these features, see Chapter 3, “Using Your MacBook Pro,” on page 53.

Putting Your MacBook Pro to Sleep or Shutting It Down

When you finish working with your MacBook Pro, you can put it to sleep or shut it down.

Putting Your MacBook Pro to Sleep

If you will be away from your MacBook Pro for only a short time, put the computer to sleep. When the computer is in sleep, you can quickly wake it and bypass the startup process.

To put the computer to sleep, do one of the following:

- Close the display.
- Choose Apple () > Sleep from the menu bar.
- Press the power (⏻) button and click Sleep in the dialog that appears.



- Choose Apple () > System Preferences, click Energy Saver, and set a sleep timer.
- Press and hold the Play/Pause (⏮) button on the Apple Remote for 3 seconds.

Warning: Wait a few seconds until the white sleep indicator light on the display latch starts pulsating (indicating that the computer is in sleep and the hard disk has stopped spinning) before you move your MacBook Pro. Moving your computer while the hard disk is spinning can damage the hard disk, causing loss of data or the inability to start up from the hard disk.

To wake the computer:

- *If the display is closed*, simply open it to wake up your MacBook Pro.
- *If the display is already open*, press the power (⏻) button or any key on the keyboard or any button on the Apple Remote.

Shutting Down Your MacBook Pro

If you aren't going to use your MacBook Pro for a day or two, it's best to shut it down. The sleep indicator light goes on briefly during the shutdown process.

To shut down your computer, do one of the following:

- Choose Apple () > Shut Down from the menu bar.
- Press the power (⏻) button and click Shut Down in the dialog that appears.

If you plan to store your MacBook Pro for an extended period of time, see “Storing Your MacBook Pro” on page 108 for information about how to prevent your battery from draining completely.

Calibrating Your Battery

To get the longest running time from your battery, calibrate it sometime during the first week you have your MacBook Pro and repeat these steps occasionally to keep your battery functioning at its fullest capacity.

To calibrate your battery:

- 1 Plug in the power adapter and fully charge your MacBook Pro battery until the light on the power adapter plug changes to green and the Battery icon in the menu bar indicates that the battery is fully charged.
- 2 Allow the battery to rest in the fully charged state for two hours or longer. You may use your computer during this time as long as the adapter is plugged in.
- 3 Disconnect the power adapter with the MacBook Pro on and start running it from the battery. You may use your computer during this time.

When your battery gets low, you will see the low battery warning dialog on the screen.

- 4 Continue to keep your computer turned on until it goes to sleep. Save your work and close all applications when the battery gets low and before the system goes to sleep.
- 5 Turn off the computer or allow it to sleep for five hours or longer.
- 6 Connect the power adapter and leave it connected until the battery is fully charged again.

Important: Repeat the calibration process occasionally to keep your battery fully functioning. If you use your MacBook Pro infrequently, it's best to recalibrate the battery at least once a month.

If you purchased additional batteries, follow the calibration procedure with those batteries as well. For more battery information, see “Using Your Battery” on page 77.

Getting More Information

For more information about your MacBook Pro, check out these resources:

- Read Chapter 2, “Getting to Know Your MacBook Pro,” on page 27 for important basics.
- If you’re unfamiliar with Mac OS X, review the *Welcome to Tiger* booklet that came with your computer and open Mac Help to browse the information there. For more information, see “Getting Answers Using Mac Help” on page 42.
- If you’re having a problem that prevents you from using your computer, see Chapter 5, “Troubleshooting,” on page 93.
- Check out the most commonly asked questions in “Top Ten Questions” on page 125.
- For support information, user discussion boards, and the latest Apple software downloads, go to www.apple.com/support.
- If you can’t find the answer to your question in these places, see the AppleCare materials that came with your computer for information about contacting Apple.

Getting to Know Your MacBook Pro

2

This chapter introduces important basics about your MacBook Pro.

Whenever you stop using your MacBook Pro, wait a few moments to let the hard disk and any disc (such as a CD or DVD) in your optical drive stop spinning before you transport the computer. Avoid jostling or bumping your MacBook Pro while discs are spinning.

Note: Your MacBook Pro uses Sudden Motion Sensor technology to help protect the hard disk if the computer is dropped or experiences extreme vibration. See “Understanding Sudden Motion Sensor Technology” on page 76 for more information.

When you use your MacBook Pro or charge its battery, it is normal for the bottom of the case to get warm. For prolonged use, place your MacBook Pro on a flat, stable surface. The bottom of the case is raised slightly to allow airflow, which keeps the unit within normal operating temperatures.

As you get to know your new MacBook Pro, you might hear system sounds during startup and when using your hard disk and optical drive. After the MacBook Pro runs for some time, small fans might turn on to cool it, producing a faint sound. System sounds such as these are part of the computer’s normal functioning.

For more safety instructions about handling and using your MacBook Pro in different locations, make sure to see Appendix B, “Safety, Use, and Care Information,” on page 105.

The rest of this chapter includes sections about using components of your MacBook Pro, such as the display, power adapter, trackpad, keyboard, built-in iSight camera, and Apple Remote, and information about Mac OS X, Mac Help, applications, and connecting to peripheral hardware.

Adjusting Your Display

Your MacBook Pro is equipped with an ambient light sensing (ALS) system (located under the speaker grille) that automatically adjusts the brightness of the display according to the available light. After you begin working with your new MacBook Pro, you might need to adjust your display so that the screen is easier to see. Use the F1 and F2 keys labeled with the brightness (☼) icon to adjust screen brightness.

To turn off the automatic display brightness feature:

- Choose Apple () > System Preferences from the menu bar. Open the Displays pane and deselect the “Automatically adjust brightness as ambient light changes” checkbox.

There are two options for your display that can optimize your battery life. You can find these options in the Energy Saver pane of System Preferences.

To set preferences for your display that optimize battery use:

- 1 Open System Preferences and click Energy Saver.
- 2 In the “Settings for” pop-up menu, choose Battery and click Options.

- 3 Deselect “Reduce the brightness of the built-in display when using this power source” if you don’t want your display to dim to save on battery consumption.

When this feature is enabled, your display dims a small amount when you go from using the power adapter with your MacBook Pro to using battery power. When you plug in the power adapter again, your display returns to its previous level of brightness. Deselect “Automatically reduce the brightness of the display before display sleep” if you don’t want the display to dim before the MacBook Pro sleeps.

Changing the Size of Images on the Screen

Your MacBook Pro has a 15.4-inch display with a default resolution of 1440 x 900.

You can increase or decrease the size of images on your screen by switching from the native resolution to a scaled resolution.

You can choose scaled resolutions in the Displays pane of System Preferences. When you switch to a scaled resolution, items on the screen appear larger, making them easier to see. Scaled resolutions might not be as sharp as the display’s default resolution.

With some resolutions, a black band appears on each side of the display. If you do not want to see the bands, you can choose a “stretched” version of the resolution to have the image cover the entire screen and eliminate the bands.

To adjust the resolution on your display:

- Choose Apple () > System Preferences from the menu bar. Open the Displays pane of System Preferences.

To control your display settings using the Displays status menu in the menu bar, click “Show displays in menu bar.”

Using Your Power Adapter

Plugging in the power adapter provides AC power to the MacBook Pro and recharges the computer's battery.

Important: For optimal performance, use only the power adapter that came with your computer, or purchase an additional 85W Apple Portable Power Adapter.

When you first connect your power adapter to your computer, an indicator light on the power adapter plug turns on. If you don't see a light, your plug is probably not seated correctly. Check for any debris and remove it, if necessary. An amber light indicates that power is going to the battery. A green light indicates that no power is going to the battery, which can mean the battery is fully charged, is not installed, or has a problem. You can monitor the battery level using the Battery status menu in the menu bar or by checking the battery level indicator lights on the bottom of the battery (see page 77).

Warning: The MacBook Pro power adapter port contains a magnet that can erase data on a credit card, iPod, or other device. To preserve your data, keep these and other magnetic media away from the power adapter port.

To extend the reach of your power adapter, first pull the AC plug up to remove it from the adapter. Attach the included AC power cord to the adapter, making sure it is seated firmly. Plug the other end into a power outlet. The AC power cord provides a grounded connection.

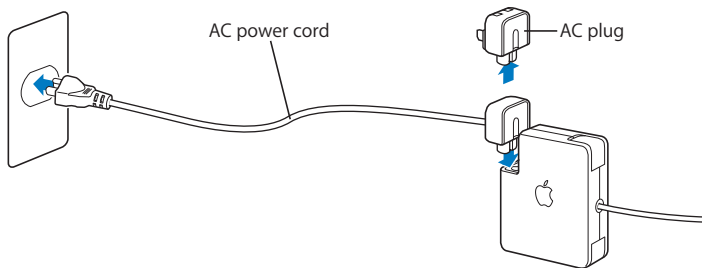

For best results, always use the AC power cord and connect it to a grounded power outlet when one is available. Use only the AC power cord that came with your power adapter. Make sure to push the power plug snugly into the power adapter port on the computer to ensure it is engaged and power is flowing to the computer. If the cord is plugged in properly, you will see an indicator light on the end of the cord that plugs into your MacBook Pro.

When disconnecting the power adapter from a power outlet or from the computer, pull the plug, not the cord. For safety instructions about using your power adapter, see “Setting Up Your MacBook Pro and Power Adapter” on page 106.

Using the Trackpad

How quickly the pointer moves onscreen is based on how quickly you move your finger across the trackpad. To move the pointer a short distance, move your finger slowly across the trackpad; the faster you move your finger, the farther the pointer moves onscreen.

You can also scroll vertically and horizontally in a window that has scroll bars by moving two fingers on the trackpad. This feature can be turned off or adjusted in the Keyboard & Mouse pane of System Preferences.

Tips for Using the Trackpad

For best results when using the trackpad, keep in mind these tips:

- Use only one finger, except when the scrolling feature is turned on and you want to scroll.
- Do not use a pen or any other object.
- Keep your finger and the trackpad dry. If the trackpad becomes moist from humidity or condensation, gently wipe it with a clean cloth before you use it.
- Never use any kind of cleaning solution on the trackpad.

For more information about using the trackpad, choose Help > Mac Help from the menu bar at the top of the screen.

Instead of using the trackpad button, you can use your finger to click and double-click directly on the trackpad. You can turn on this feature and other trackpad options in the Keyboard & Mouse pane of System Preferences.

Note: If you find that the pointer moves as you type because you accidentally brush the trackpad, you can avoid this problem by selecting the “Ignore accidental trackpad input” option in the Keyboard & Mouse pane of System Preferences.

Using the Keyboard

Your MacBook Pro keyboard has a numeric keypad incorporated in the standard keyboard keys. Keys used for the numeric keypad have a smaller secondary label.

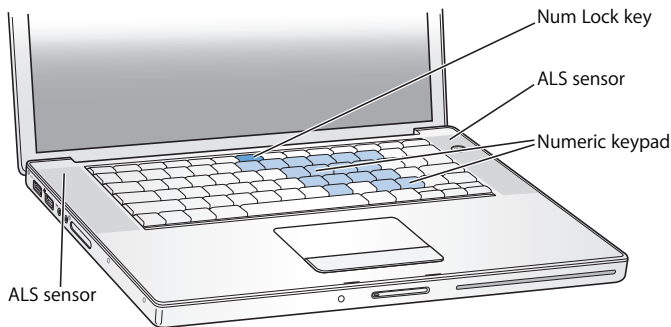

To use the numeric keypad, press the Num Lock key. The Num Lock key glows green, indicating that the keypad is active. When you finish using the keypad, press the Num Lock key again to turn it off.

Important: If your keyboard doesn't seem to be working correctly, check the Num Lock key. When the numeric keypad is active, other keys and keyboard equivalents for menu commands (such as ⌘ -Q to quit) are deactivated.

Your MacBook Pro is equipped with an illuminated keyboard that is adjusted by the ambient light sensing (ALS) system according to the available light in your operating environment.

You can also adjust the keyboard illumination using the F8, F9, and F10 keys.

Important: Even when the keyboard illumination feature is on, the keyboard illuminates only in low-light situations.

You can turn off the keyboard illumination feature in the Keyboard & Mouse pane of System Preferences or by pressing the F8 key.

Note: Exposé is preset to use the F9 and F10 keys, the same keys that adjust your keyboard illumination. To use Exposé to manage your desktop windows, hold down the Fn key and press F9 or F10, or open the Dashboard & Exposé pane in System Preferences and choose different function keys to manage the windows.

You can use your keyboard as well as your Apple Remote to control the Front Row application. See “Using the Keyboard to Control Front Row” on page 38.

If you like to use keyboard shortcuts to work efficiently, choose Help > Mac Help from the menu bar and search for “navigation shortcuts.” You’ll find a list of keyboard shortcuts for many common procedures and applications.

Using a Mouse

If you have an Apple mouse with a USB connection, you can insert the USB connector into the USB 2.0 port and use your mouse right away. If you want to use an Apple wireless mouse with Bluetooth® technology, see “Using Bluetooth Wireless Technology” on page 64 for information about connecting it. You can purchase a wireless or USB mouse from the online Apple Store at www.apple.com/store or from an Apple Authorized Reseller.

Using the Apple Remote and Front Row

Your Apple Remote works with the Front Row interface and the built-in infrared (IR) receiver, which is located next to the display release button on your MacBook Pro. Use the Apple Remote to open Front Row and work with iTunes, iPhoto, QuickTime, DVD Player, and more from across the room.

Use your Apple Remote to:

- Open Front Row and navigate through the Music, Photos, Videos, and DVD menus.
- Adjust the volume of a song, play or pause a song, or skip to the next or previous track in iTunes.
- Play a slideshow of any of your photo albums in iPhoto.
- Play movies that are in your Movies folder or watch online QuickTime movie trailers.
- Play a DVD in your optical drive with DVD Player.
- Sleep or wake your MacBook Pro.

To use your Apple Remote:

- Press the Menu (**MENU**) button to open Front Row.
- Use the Menu (**MENU**) button to return to the previous menu while you're navigating.
- Press the Volume/Menu Up (**+**) and Volume/Menu Down (**-**) buttons to move through the menu options and adjust the volume.
- Press the Select/Play/Pause (**▶||**) button to select an option from the menu.
- Press the Select/Play/Pause (**▶||**) button to play or pause a song, slideshow, or movie.
- Press the Next/Fast-forward (**▶▶**) or Previous/Rewind (**◀◀**) button to skip to the next or previous song in iTunes or the next or previous chapter in a DVD movie.

- Hold down the Next/Fast-forward (▶▶) or Previous/Rewind (◀◀) button to fast-forward or rewind within a song or movie.
- Hold down the Play/Pause (▶||) button for 3 seconds to put your MacBook Pro to sleep.

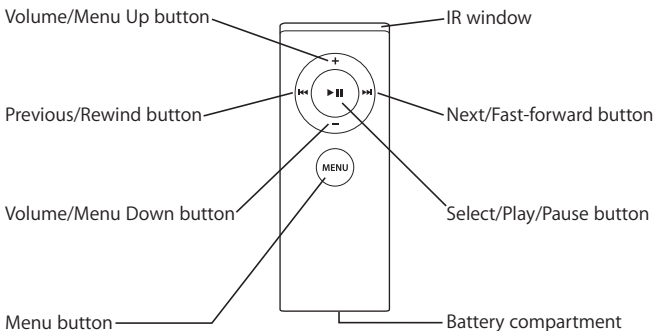

Pairing Your Apple Remote

If you have multiple computers or other devices with built-in IR receivers in a room (for example, more than one MacBook Pro or iMac in a home office or lab), you can “pair” your Apple Remote with a specific computer or device. Pairing sets up the receiving computer or device to be controlled by a specific Apple Remote.

To pair your Apple Remote with your MacBook Pro:

- 1 Position the Apple Remote 3 to 4 inches from the IR receiver on your MacBook Pro.
- 2 Press and hold the Menu (MENU) and Next/Fast-forward (▶▶) buttons on the Apple Remote for 5 seconds.

When you successfully pair your Apple Remote with your MacBook Pro, you will see a chainlink symbol (⌘) onscreen.

To delete a pairing between the Apple Remote and your MacBook Pro:

- 1 Choose Apple () > System Preferences from the menu bar.
- 2 Click Security and then click Unpair.

Replacing the Battery

The Apple Remote includes a battery. When needed, replace the battery with a CR 2032 battery.

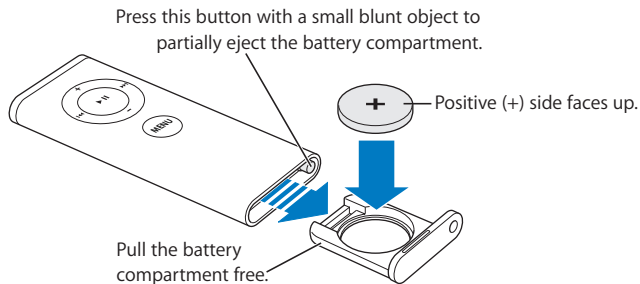

To replace the battery:

- 1 Open the battery compartment by pressing the button (pictured above) with a small object, such as the end of a paper clip.
- 2 Pull the battery compartment out and remove the battery.
- 3 Insert the replacement battery with the positive (+) side facing up.

4 Close the battery compartment.

Turning Off IR Reception

You can use Security preferences to turn IR reception on your MacBook Pro on or off.

To turn off IR reception:

- Choose Apple (🍏) > System Preferences from the menu bar and click Security.
- Select the “Disable remote control infrared receiver” checkbox.

Using the Keyboard to Control Front Row

In addition to using the Apple Remote to control Front Row, you can also use your keyboard. The following keys correspond to the buttons on the Apple Remote:

Keyboard equivalent	Apple Remote button
Command (⌘) - Esc	Enter Menu (MENU)
Esc	Exit Menu (MENU)
Space or Return	Select/Play/Pause (▶)
Up arrow (↑)	Volume/Menu Up (⊕)
Down arrow (↓)	Volume/Menu Down (⊖)
Right arrow (→)	Next/Fast forward (▶▶)
Left arrow (←)	Previous/Rewind (◀◀)

Getting More Information About the Apple Remote

More information about your Apple Remote is available in Mac Help. Choose Help > Mac Help from the menu bar and search for “Apple Remote.”

Using the Built-in iSight Camera

With the built-in iSight camera, you can take pictures with Photo Booth or video chat with other iChat AV users.

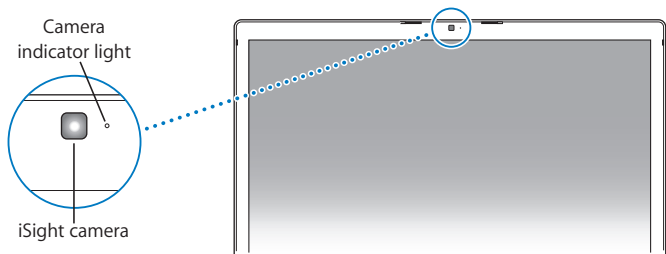

Taking Pictures with Photo Booth

Use Photo Booth to take pictures and add fun visual effects such as sepia, black and white, glow, colored pencil, and more.

To take a picture with Photo Booth:

- 1 Click the Photo Booth icon in the Dock (or choose Applications > Photo Booth) to open Photo Booth and turn on the built-in iSight camera.

The green indicator light next to the camera tells you it's on.

- 2 Select an effect to apply to your picture, if you like.
- 3 Click the Camera icon below the image to take a picture.

Save your photo as your iChat buddy picture, email it to your friends, or save it in your iPhoto library.

To use a picture as your buddy picture or account picture:

- 1 Open Photo Booth and take a picture.
- 2 Select the picture you'd like to use as your buddy picture or account picture.
- 3 Click the Buddy Picture or Account Picture icon to automatically update your picture.

More information about Photo Booth is available by choosing Help > Mac Help from the menu bar, and then choosing Library > Photo Booth Help.

Using Your iSight Camera with iMovie HD

You can capture live video from your built-in iSight camera directly into iMovie HD.

To capture live video:

- 1 Open iMovie HD by clicking its icon in the Dock (or choose Applications > iMovie HD).
- 2 Click the mode switch to set iMovie HD to built-in camera mode.

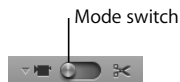

- 3 Click the camera icon to the left of the mode switch and choose Built-in iSight from the pop-up menu.
- 4 Click the “Record With iSight” button in the iMovie monitor to begin recording.
The video you see in the iMovie monitor is recorded as a clip in the iMovie Clips pane.
- 5 Click the “Record With iSight” button again to stop recording.
You can record video as long as your MacBook Pro has enough disk space to hold it.

More information about iMovie HD is available in Mac Help. Choose Help > Mac Help, then choose Library > iMovie HD Help from the menu bar.

Videoconferencing with iChat AV

When you open iChat AV, the green indicator light goes on. Click the video icon of a buddy to videoconference with another iChat AV user in real-time full-motion video. Your MacBook Pro also has a built-in microphone, so you have both voice and video support for iChat AV videoconferences.

To use the built-in iSight to videoconference, you must have the following:

- A .Mac, America Online (AOL), or AOL Instant Messenger (AIM) account (required for iChat AV).
- A broadband Internet connection using a DSL or cable modem, or a local area network (LAN). Note that a dial-up Internet connection doesn't support this activity.

To start a videoconference:

- 1 Open iChat AV.
- 2 Click the Camera button next to a buddy in your buddy list.

For information about adding people to your buddy list, choose Help > iChat AV Help.

Clicking a Camera button in the buddy list illuminates the green indicator light to indicate you are recording video. This also sends an invitation to your buddy to accept your video request and lets you preview how you look on camera. When a buddy accepts your invitation, you can see him or her on your screen as well as yourself.

Videoconferencing with More Than One Buddy

You can videoconference with up to three buddies at once. One buddy “hosts” the videoconference, and the others participate.

To start a videoconference with more than one buddy:

- 1 Open iChat AV.
- 2 Hold down the Command key while you select the buddies you want to invite.
- 3 Click the Camera button at the bottom of your buddy list.

Turning Off the iSight Camera

To turn off your iSight camera, close the active iChat window. The green indicator light turns off, indicating that the iSight camera is off and recording has stopped.

Using Your Picture as Your Buddy Icon

You can take a picture of yourself using the iSight camera and use it as your buddy icon. People who have placed you in their buddy lists will see this picture.

To set your buddy icon:

- 1 Open iChat AV.
- 2 Choose Buddies > Change My Picture.
- 3 Click the Camera button.

Getting Answers Using Mac Help

Most of the information about using your Macintosh is available right on your computer in Mac Help. You'll find plenty of information for new users, experienced users, and people switching to the Mac.

To access Mac Help:

- 1 Click the Finder icon in the Dock (the bar of icons at the bottom of the screen).



- 2 Choose Help > Mac Help (click the Help menu in the menu bar and choose Mac Help).

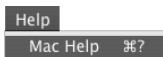

- 3 Click in the search field, type a question, and press Return on your keyboard.

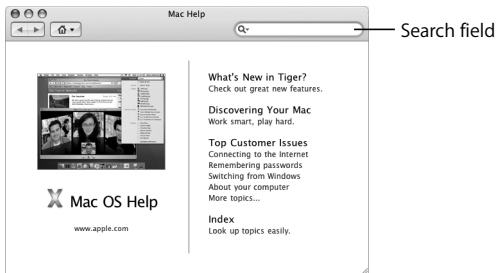

Learning About Mac OS X

Your computer comes with Mac OS X v10.4 Tiger, which includes Spotlight, a search engine that automatically indexes all of your files; Dashboard, an interface for putting handy “widgets” or mini-applications at your fingertips; Exposé, which tiles and neatly displays all your open applications; and much more.

When you’re ready to learn more about Mac OS X and the award-winning iLife applications that came with your computer, see the *Welcome to Tiger* booklet that came with your MacBook Pro or browse the information in Mac Help. If you experience any problems while using Mac OS X, see Chapter 5, “Troubleshooting,” or Mac Help.

For information about the software applications compatible with Mac OS X or to read more about Mac OS X, check the Apple website at www.apple.com/macosx.

Customizing Your Desktop and Setting Your Preferences

You can quickly make your desktop look the way you want using System Preferences. Choose Apple (🍏) > System Preferences from the menu bar.

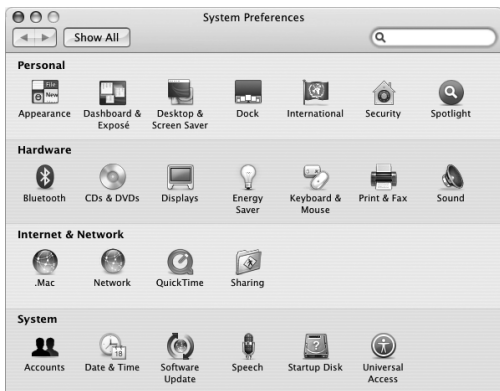

Feel free to make changes and experiment with the following:

- *Appearance*: Select this preferences pane to change the colors of buttons, menus, windows, and highlight colors, among other options.
- *Dashboard & Exposé*: Select this preferences pane to set active screen corners and shortcuts for Dashboard, the desktop, your application windows, and all windows.

- *Desktop & Screen Saver*: Select this preferences pane to change the background color or pattern of your desktop, or change it to a photo or image you like. You can also choose an eye-catching screen effect that will appear on your screen when the computer is left idle.
- *Dock*: Select this preferences pane to change the look, location, and behavior of your Dock (the bar of icons along the edge of the screen).

As you get to know your computer, explore the other system preferences. System Preferences is your command center for most settings on your MacBook Pro. For more information, open Mac Help and search for “System Preferences” or for the specific preferences pane you want to change.

Note: Because Apple frequently releases new versions and updates to its system software, applications, and Internet sites, images shown in this book might be slightly different from what you see on your screen.

Using Applications

Your MacBook Pro comes with software applications for sending email, surfing the Internet, and chatting online. It also includes the iLife suite of applications for activities such as organizing music and digital photos, making movies, and much more. For more information about these applications, see the *Welcome to Tiger* booklet that came with your computer.

When an Application Does Not Respond

On rare occasions, an application may “freeze” on the screen. Mac OS X provides a way to quit a frozen application without restarting your computer. Quitting a frozen application might allow you to save your work in other open applications.

To force an application to quit:

- 1 Press Command (⌘)-Option-Esc or choose Apple () > Force Quit from the menu bar. The Force Quit Applications dialog appears with the application selected.
- 2 Click Force Quit.

The application quits, leaving all other applications open.

If you need to, you can also restart the Finder from this dialog.

If you're experiencing other problems with an application, see Chapter 5, “Troubleshooting,” on page 93.

Keeping Your Software Up to Date

You can connect to the Internet and automatically download and install the latest free software versions, drivers, and other enhancements from Apple.

When you are connected to the Internet, Software Update checks Apple's Internet servers to see if any updates are available for your computer. You can set your Mac to check the Apple server periodically and download and install updated software.

To check for updated software:

- 1 Open System Preferences.
- 2 Click the Software Update icon and follow the directions on the screen.
 - For more information, search for “Software Update” in Mac Help.
 - For the latest information about Mac OS X, go to the Mac OS X website at www.apple.com/macosx.

Connecting to a Printer

Follow the instructions that came with your printer to install the required software and connect the printer. The drivers for most printers are built into Mac OS X.

You can connect many printers with a USB cable; others require a network connection, such as Ethernet. If you have an AirPort Express or AirPort Extreme Base Station, you can connect a USB printer to the base station (instead of connecting it to your computer) and print wirelessly. For more information about your USB ports, see “Using Universal Serial Bus Devices” on page 54. For more information about a wireless or network connection, see “How AirPort Provides Wireless Internet Access” on page 62 and “Connecting with Ethernet” on page 66.

After you connect a USB or FireWire printer, your computer usually detects it automatically and adds it to the list of available printers. You might need to know the network name or address of printers connected to a network before you can print to them. Use the Print & Fax pane of System Preferences to select your printer.

Note: If your printer is not working, you might need to check the web site of the printer for compatible printer driver software to install.

To set up a printer:

- 1 Open System Preferences and click the Print & Fax icon.
- 2 Click Printing and then click the Add (+) button to add a printer.
- 3 Select the printer you want to use, and then click Add.
- 4 Use the Add (+) and Remove (–) buttons to choose the printers that appear in the printer list.

Monitoring Printing

After you send a document to a printer, you can monitor printing, including deleting your print job or putting it temporarily on hold. Click the printer icon in the Dock to open the Printer window. For more information, choose Help > Mac Help and search for “printing.”

Playing a CD and Connecting Headphones

You can use iTunes—an easy-to-use digital jukebox and store from which you can download music, videos, podcasts, and audiobooks—to listen to your iTunes music and CDs while you work. Insert a music CD in your optical drive and iTunes appears automatically on the screen. You can listen to your music on the MacBook Pro internal speakers or connect headphones to the headphone port of your MacBook Pro for private listening.

To learn more about iTunes:

- Open iTunes and choose Help > “iTunes and Music Store Help.”

Connecting a Camera or Other FireWire or USB Device

If you have an iPod, digital camera, video camera, scanner, or other device that has a USB or FireWire connector, you can connect it to your MacBook Pro. Follow the installation instructions that came with your device. For more information about FireWire, see “Connecting with FireWire” on page 57. For more information about USB, see “Using Universal Serial Bus Devices” on page 54.

Transferring Files to Another Computer

If you want to transfer files or documents to or from your MacBook Pro, there are several ways of doing it.

- You can easily transfer files using Migration Assistant and a FireWire cable (sold separately). You can also connect to another Mac using a FireWire cable and start up your MacBook Pro in FireWire Target Disk Mode. Your MacBook Pro appears as a hard disk on the other computer and you can drag files to it. For information about using FireWire to transfer files, see “Connecting Your MacBook Pro to Another Computer Using FireWire” on page 60.
- If you have an external hard disk drive, iPod, flash drive, or other data storage device that connects through a USB or FireWire cable, you can use it to transfer files.
- If you have an email connection, you can email your files to another computer.
- If you register for a .Mac account from Apple (fees apply), you can use it to transfer files. With a .Mac account, you get an iDisk, which provides Internet space for backing up and storing files so that other computers can access the files you transfer there.
- If the other computer has a recordable optical drive, you can transfer files that you have recorded on a CD or DVD disc.

- If you connect your computer to a network using Ethernet, you can transfer files to another computer on a network. You can access a server or another computer by clicking Network in the Finder sidebar, or by choosing Go > Connect to Server from the menu bar.
- You can create a small Ethernet network by connecting an Ethernet cable from your MacBook Pro to another computer's Ethernet port. After you're connected, you can transfer files directly from one computer to the other. For more information, open Mac Help and search for "connecting two computers."
- You can connect to an AirPort Extreme wireless network to transfer files. For more information, see "How AirPort Provides Wireless Internet Access" on page 62.
- If you have access to devices that communicate using Bluetooth wireless technology, you can transfer files to other Bluetooth equipped devices. For more information, see "Using Bluetooth Wireless Technology" on page 64.

For general information about transferring files and documents, open Mac Help and search for "transferring" or for the type of connection you need.

Your MacBook Pro has many built-in features and connection capabilities.

These include the following:

- Universal Serial Bus (USB) 2.0 ports for connecting additional equipment such as iPods, printers, scanners, and other devices. See “Using Universal Serial Bus Devices” on page 54.
- A FireWire 400 port for connecting high-speed equipment such as digital video cameras and external hard drives. See “Connecting with FireWire” on page 57.
- An ExpressCard/34 slot. See “Using ExpressCards” on page 61.
- Bluetooth wireless connectivity, AirPort Extreme wireless networking capability, and Ethernet networking capability. See “Using Bluetooth Wireless Technology” on page 64, “How AirPort Provides Wireless Internet Access” on page 62, and “Connecting with Ethernet” on page 66.
- An audio line in/optical digital audio in port and a headphone/optical digital audio out port for connecting headphones, speakers, microphones, and digital audio equipment. See “Connecting Speakers and Other Audio Devices” on page 71.

- DVI video output with included DVI to VGA adapter for using your MacBook Pro with an external monitor or digital flat-panel display, including support for closed-lid operation, video mirroring, and extended desktop (dual-display) modes. Use the Apple DVI to Video Adapter, available separately, to display content on your TV. See “Using External Video Support” on page 67.
- A SuperDrive for playing and burning CDs and DVDs. See “Using Your SuperDrive” on page 72.
- Sudden Motion Sensor technology that helps protect the internal hard disk if the MacBook Pro is dropped or experiences severe vibration. See “Understanding Sudden Motion Sensor Technology” on page 76.
- A security slot to help prevent theft of your computer. See “Securing Your MacBook Pro” on page 81.

Using Universal Serial Bus Devices

Your MacBook Pro comes with two USB 2.0 (ψ) ports, also referred to as Hi-Speed USB, which you can use to connect many types of external devices, including iPods, printers, scanners, digital cameras, game pads, joysticks, keyboards, and floppy disk drives. Your USB 2.0 ports are compatible with earlier USB devices. In most cases, you can connect and disconnect a USB device while the computer is running. After you connect the device, it is ready to use. You don't need to restart or reconfigure your computer.

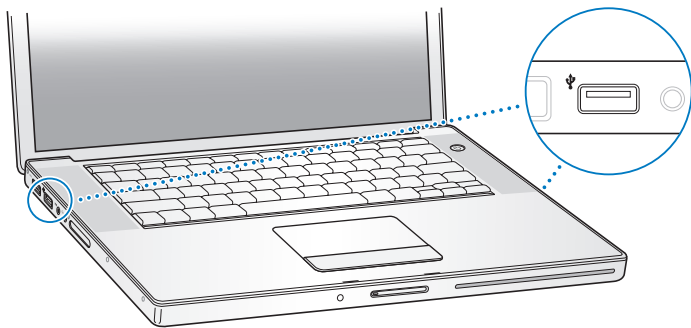

To use a USB device with your computer, connect the device to the computer. Your computer automatically detects newly connected devices and loads the correct software to work with the device.

Note: If your MacBook Pro cannot find the correct software when you connect a USB device, you can either install the software that came with the device or go to the website of the device manufacturer to locate and install the correct software.

Understanding USB Devices and Battery Power

You can use USB devices, such as joysticks and keyboards, which are powered by the MacBook Pro USB connection instead of a separate power adapter. However, these types of USB devices can cause your MacBook Pro battery to become depleted faster. If you are using the device for an extended period, it is a good idea to connect the MacBook Pro power adapter.

Using Multiple USB Devices at the Same Time

You can purchase a USB hub to connect multiple USB devices to your computer.

The USB hub connects to an open USB port on your computer and provides additional USB ports (usually four or seven). Hi-Speed hubs can support USB 2.0 Hi-Speed devices as well as USB 1.1-compatible devices. USB 1.1 hubs don't allow Hi-Speed USB devices to operate at their maximum data speed. Some USB hubs have a power adapter and should be plugged into a power outlet.

Note: If you are using a chain of USB devices and hubs, some USB devices may not work when connected through a combination of USB 2.0 Hi-Speed hubs and USB 1.1 full-speed or low-speed hubs. For example, you might not see an external USB hard disk on your desktop. To avoid this problem, do not connect USB devices with different speeds together. Connect your Hi-Speed hub directly to your computer and connect Hi-Speed devices to it. Connect a full-speed or low-speed hub directly to your computer and connect similar-speed devices to it.

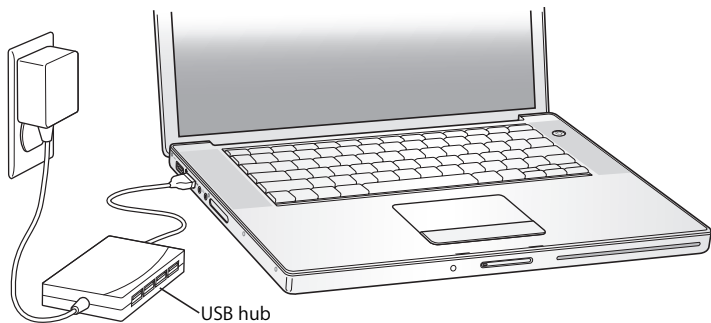

Getting More Information About USB

Additional information about USB is available in Mac Help. Choose Help > Mac Help in the menu bar and search for “USB.” You can also find information on the Apple USB website at www.apple.com/usb. For information about USB devices available for your computer, check the Macintosh Products Guide at www.apple.com/guide.

Connecting with FireWire

Your computer has one FireWire 400 (⌘) port. With FireWire, you can easily connect and disconnect external high-speed devices—such as high definition video (HDV) or digital video (DV) cameras and hard disks—without restarting your computer.

You can connect a standard 6-pin FireWire device directly to the FireWire 400 (⌘) port. The port provides power to connected devices, so the devices don’t need a separate power plug.

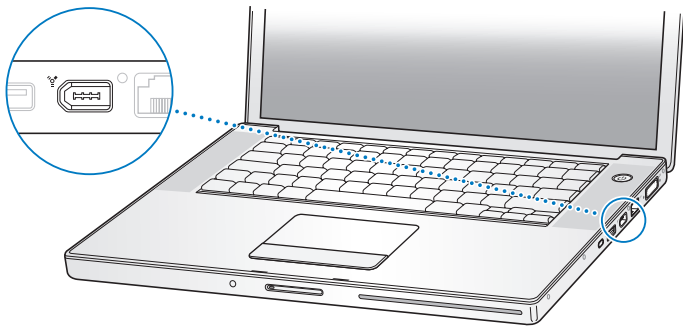

These are some of the things you can do with FireWire:

- Connect a HDV or DV camera and capture, transfer, and edit high-quality video directly on your computer using video editing software such as iMovie HD or Final Cut Express.
- Connect an external FireWire hard disk drive and use it to back up data or transfer files.
- Start up from an external FireWire hard disk. Connect an external FireWire hard disk (with Mac OS X v10.4.4 installed on it), open the Startup Disk pane of System Preferences, and click the FireWire hard disk. Restart your computer.
- Transfer files between your MacBook Pro and another FireWire-equipped computer using FireWire Target Disk Mode. See “Connecting Your MacBook Pro to Another Computer Using FireWire” on page 60 for more information.

Using FireWire Devices

To use a FireWire device with your computer, connect the device to the computer and install any software that came with the device. Your computer automatically detects newly connected devices.

Note: If your MacBook Pro cannot find the correct software when you connect a FireWire device, you can either install the software that came with the device or go to the website of the device manufacturer to locate and install the correct software.

Understanding FireWire Devices and Battery Power

You can use FireWire devices, such as certain external hard disks, which are powered by the MacBook Pro FireWire connection instead of a separate power adapter. However, these types of FireWire devices can cause your MacBook Pro battery to become depleted faster. If you are using the device for an extended period, it is a good idea to connect the MacBook Pro power adapter.

Note: The FireWire port is designed to support power for FireWire devices (up to 7 watts maximum). You can connect multiple devices to each other and connect the chain of devices to the FireWire port on your computer, but only one device should get power from the computer. The rest of the devices in the chain should be powered by separate power adapters. Connecting more than one FireWire device that gets power from the port can cause problems. If a problem occurs, shut down the computer, disconnect the FireWire devices, and restart your computer.

Connecting Your MacBook Pro to Another Computer Using FireWire

If you want to transfer files between your MacBook Pro and another FireWire-equipped Macintosh computer, or if you have a problem that prevents your computer from starting up, you can use FireWire Target Disk Mode to connect to another computer. When you start up your computer in FireWire Target Disk Mode, the other computer can access your MacBook Pro as if it were an external hard disk.

Note: When using FireWire Target Disk Mode, it's a good idea to connect your power adapter to the MacBook Pro.

To connect your MacBook Pro to another computer in FireWire Target Disk Mode:

- 1 Make sure that your MacBook Pro is shut down.
- 2 Use a FireWire cable to connect your MacBook Pro to another FireWire-equipped computer.
- 3 Start up your MacBook Pro and immediately hold down the T key.
Your MacBook Pro display shows the FireWire logo. The other computer's display shows the MacBook Pro internal hard disk icon. You can now drag and drop files between the computers.
- 4 When you finish transferring files, drag the MacBook Pro hard disk icon to the Trash (Eject icon).
- 5 Press the power (⏻) button on the MacBook Pro to shut it down, and then disconnect the FireWire cable.

Getting More Information About FireWire

More information about FireWire is available in Mac Help. Choose Help > Mac Help in the Finder menu bar and search for “FireWire.” You can also find information on the Apple FireWire website at www.apple.com/firewire.

Using ExpressCards

You can expand your computer’s capabilities using the ExpressCard/34 slot. You can connect a TV tuner, flash memory cards, and more. Your MacBook Pro has one ExpressCard/34 slot that accepts 34mm ExpressCards. You can insert an ExpressCard when your computer is on, off, or in sleep.

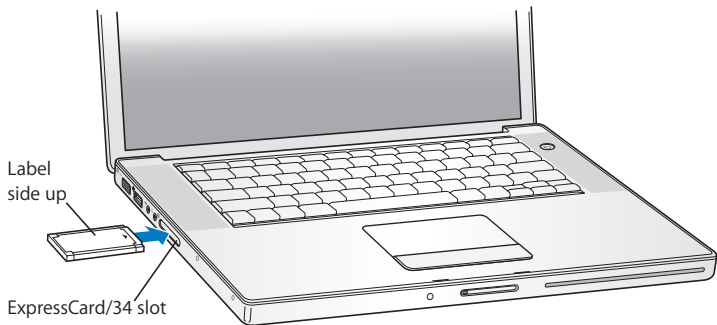

Inserting and Ejecting an ExpressCard

When inserting an ExpressCard, make sure the label is facing up and the card is level. You'll feel some resistance as you slide in the card. When the card is firmly seated in the slot, it clicks into place and an icon appears on the desktop. You can eject an ExpressCard when your computer is on or off, but not when it is in sleep.

To eject an ExpressCard:

- 1 If the computer is turned on, drag the card's icon to the Trash (Eject icon).
- 2 Push gently on the card to activate the spring, and then pull the card out of the slot.

Getting More Information About ExpressCards

For information about the ExpressCards available for your MacBook Pro, check the Macintosh Products Guide at www.apple.com/guide.

How AirPort Provides Wireless Internet Access

With AirPort Extreme technology, your MacBook Pro makes a wireless connection to an AirPort Express, AirPort Extreme Base Station, or any 802.11a-, 802.11b-, or 802.11g-compliant product that is connected to the phone line, a DSL or cable modem, or a local-area network with Internet access.

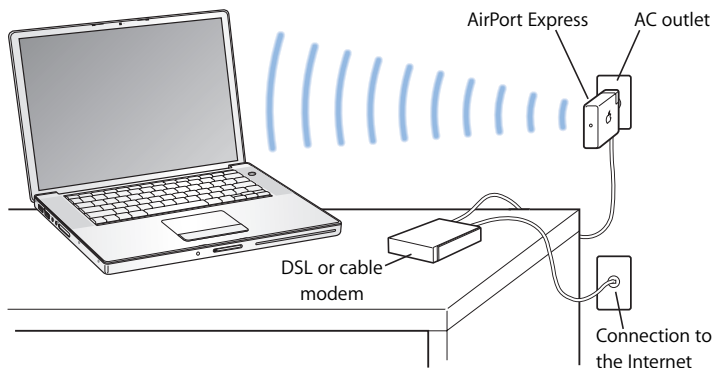

Getting More Information About AirPort Extreme

To purchase an AirPort Extreme Base Station or AirPort Express, go to the online Apple Store at www.apple.com/store or contact an Apple Authorized Reseller.

More information about AirPort Extreme and AirPort Express is available in AirPort Help. Choose Help > Mac Help, and then choose Library > AirPort Help. You can also find information on the Apple AirPort website at www.apple.com/airport.

Using Bluetooth Wireless Technology

Your MacBook Pro comes with Bluetooth wireless technology. With Bluetooth, you can make short-range wireless connections between desktop and portable computers, personal digital assistants (PDAs), mobile phones, camera phones, printers, digital cameras, and wireless input devices such as the Apple Wireless Keyboard and Apple Wireless Mouse (available for purchase from the online Apple Store at www.apple.com/store).

Bluetooth wireless technology eliminates the need for many cables that traditionally connect devices together. Bluetooth enabled devices can connect to each other wirelessly at distances of up to 33 feet (10 meters).

With Bluetooth wireless technology, you can do the following:

- Use your MacBook Pro to communicate with a compatible Bluetooth enabled mobile phone. Your phone can act as a modem to connect you to a wireless service provider, at speeds of up to 56 kilobits per second (kbit/s), so you can use your mobile phone to access the Internet.
- Synchronize with your handheld Bluetooth enabled PDA. Using iSync, you can perform a HotSync operation without cables or send your business card or calendar events directly to a colleague's PDA.
- Exchange files between Bluetooth enabled computers and devices—even Mac to PC.
- Use a Bluetooth wireless printer, keyboard, mouse, or headset.

Setting Up a Bluetooth Device

Before you can use a Bluetooth device with your MacBook Pro, you need to set up the device to work with your computer. After you set up the device, it is “paired” with your computer, and you can see it in the Devices pane of Bluetooth preferences. You pair your computer with the device only once, and they remain paired until you delete the pairing.

To set up a Bluetooth device:

- 1 Choose Bluetooth (⌘) status menu > Set up Bluetooth Device.
- 2 Follow the onscreen instructions for the type of device you want to set up.

Important: If the Bluetooth (⌘) status menu is not in the menu bar, open System Preferences and click Bluetooth. Click Settings and then select “Show Bluetooth status in the menu bar.”

To delete a pairing with a Bluetooth enabled device:

- 1 Open System Preferences and click Bluetooth.
- 2 Click Devices and select the device from the list.
- 3 Click Delete.

Getting More Information About Bluetooth Wireless Technology

You can find out more about using Bluetooth wireless technology by opening the Bluetooth File Exchange application (located in the Utilities folder within the Applications folder) and choosing Help > Bluetooth Help. You can also find information on the Apple Bluetooth website at www.apple.com/bluetooth.

Connecting with Ethernet

Your computer comes with built-in Ethernet (↔) networking capability, which you can use to connect to a network or to a cable or DSL modem.

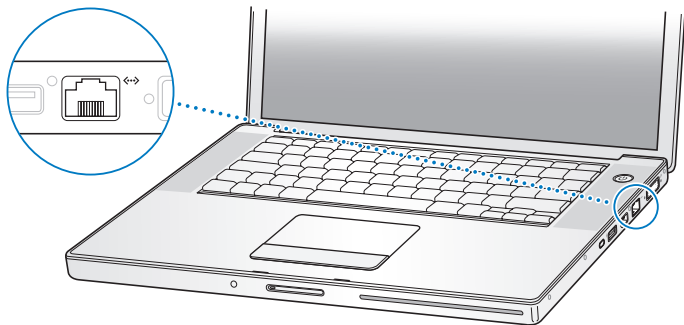

Connecting to a network gives you access to other computers and potentially to network printers, modems, email, and the Internet. You can use Ethernet to share files between two computers or set up a small network. The Ethernet port on your MacBook Pro automatically detects other Ethernet devices. You don't need an Ethernet crossover cable when connecting to other Ethernet devices. Use a 2-pair category 5 (or higher) Ethernet cable to connect to a 10Base-T, 100Base-T, or 1000Base-T Ethernet network.

Getting More Information About Using Ethernet

More information, including setting up an Ethernet network and transferring files using Ethernet, is available in Mac Help. Choose Help > Mac Help and search for “Ethernet” or “network.”

For information about networking products you can use with your MacBook Pro, check the Macintosh Products Guide at www.apple.com/guide.

Using External Video Support

Your computer has an external monitor (DVI) port that allows you to directly connect a display or projector with a DVI port. Use the included DVI to VGA adapter to connect your MacBook Pro to monitors and projectors that have VGA connectors.

You can display images on a TV, record computer images on a VCR, or play DVD-Video discs on your TV by connecting the Apple DVI to Video Adapter (available separately). You can purchase the Apple DVI to Video Adapter from an Apple Store retail location, the online Apple Store at www.apple.com/store, or an Apple Authorized Reseller.

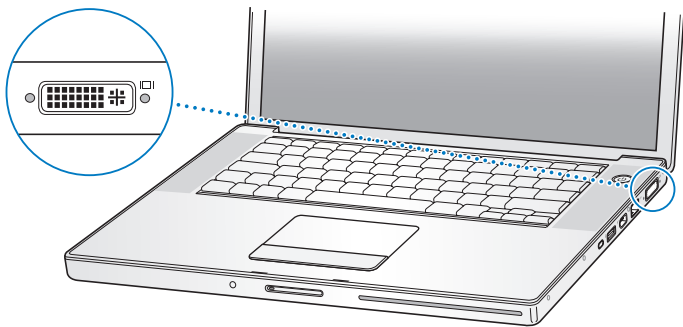

When an external monitor or TV is connected, you can either have the same image appear on both the built-in display and the external monitor (known as *video mirroring*) or use the external monitor to extend the size of the Mac OS desktop (known as *dual-display* or *extended desktop mode*). By default, your MacBook Pro starts up in dual-display mode. Press the F7 (\square) key to switch between dual-display and video-mirroring modes.

If you want sound to come from the external display, such as a projector or TV, you need to connect an audio cable (not included) from the computer's headphone ($\hat{\text{H}}$) port to that device.

Note: Because of the display limitations of most TVs, images displayed on the TV screen will be of lower quality than those on the built-in display or an external monitor.

Connecting an External Display or Projector

To connect an external display or projector with a DVI connection to your computer:

- 1 Turn on the external display or projector.
- 2 Make sure the display cable is connected to the external projector or display.
- 3 Connect the display cable to your MacBook Pro. Your MacBook Pro automatically detects the external display.
- 4 Adjust the resolution on the external display by using the Displays pane of System Preferences or the Displays status menu in the menu bar.

To connect an external display or projector with a VGA connection to your computer:

- 1 Turn on the external display or projector.
- 2 Make sure the display cable is connected to the external projector or display.
- 3 Connect the DVI to VGA adapter that came with your MacBook Pro to the VGA connector of the external display or projector, and then connect the adapter to your MacBook Pro.

Your MacBook Pro automatically detects the external display.

- 4 Adjust the resolution on the external display by using the Displays pane of System Preferences or the Displays icon in the menu bar.

Using Your MacBook Pro with the Display Closed

You can use your MacBook Pro with the display closed if the computer is connected to an external monitor, keyboard, and mouse.

Important: To use your MacBook Pro with the display closed, the power adapter must be plugged into the MacBook Pro and a functioning power outlet.

To operate your computer with an external monitor attached and the display closed:

- 1 Connect a USB keyboard and mouse to your MacBook Pro.
- 2 Connect the power adapter to the MacBook Pro and a power outlet. Check that the power adapter light is on.
- 3 Close the MacBook Pro display to put the computer to sleep.
- 4 Follow the steps in the previous section to connect your MacBook Pro to an external display.
- 5 Wait a few seconds and then press any key on the external keyboard to wake the MacBook Pro.

Connecting a TV, VCR, or Other Video Device

To connect a TV, VCR, or other video device to your MacBook Pro:

- 1 Connect the Apple DVI to Video Adapter (available separately) to the DVI port on your MacBook Pro.
- 2 If you want to send the sound from your MacBook Pro to the device, connect a miniplug-to-RCA cable (not included) from the headphone (🔊) port on your MacBook Pro to the audio input ports on your device.
- 3 Turn on the external device.
- 4 To detect the TV or other external device, hold down the Command (⌘) key and press the F2 key.
- 5 To adjust how the images are displayed on the device, use the Displays pane of System Preferences.

Connecting an Apple Flat-Panel Display

You can connect your MacBook Pro to an Apple flat-panel display. Depending on the display used, the connection might require a DVI to ADC adapter, available from an Apple Store retail location, the online Apple Store at www.apple.com/store, or an Apple Authorized Reseller.

Getting More Information About Using an External Monitor or TV

Additional information about using and configuring an external monitor is available in Mac Help. Choose Help > Mac Help from the menu bar and search for “monitor.”

Connecting Speakers and Other Audio Devices

Your MacBook Pro comes with two built-in speakers, a built-in microphone, an audio line in/optical digital audio in port, and a headphone/optical digital audio out (🎧) port.

You can connect external speakers, headphones, 5.1 surround systems, and other sound output devices to the headphone (🎧) port. The headphone port is also a S/PDIF stereo 3.5 mini-phono jack. When devices are plugged in, sound won't come through your built-in speakers. Unplug any headphones or speakers to hear the computer speakers.

You can record sound onto your hard disk using the built-in microphone located under the left speaker grille. You can also connect external microphones or other audio equipment to the audio line in port. The audio line in port is also a S/PDIF stereo 3.5 mini-phono jack, which does not provide power to a connected device, so you must use self-powered peripherals. Using a Toslink jack-to-miniplug adapter, you can use a Toslink cable to connect Digital Audio Tape (DAT) decks or digital instruments to input and mix your own music.

For applications that can record sound, such as iMovie, use the Sound pane of System Preferences to select the audio input device you want to use, including microphones connected through USB.

The volume controls on your keyboard allow you to easily change volume. You can also access these controls from the Sound pane of System Preferences.

For more information about using or troubleshooting sound on your computer, choose Help > Mac Help and search for “sound.”

Using Your SuperDrive

With your SuperDrive, you can:

- Install or use software from CDs or DVDs
- Play multimedia on CD discs and music from audio CDs
- Write music, documents, and other digital files to CD-R and CD-RW discs
- Play DVD movies and use most DVD discs (single-layer)
- Record information on blank single-layer DVD-R, DVD-RW, DVD+R, and DVD+RW discs

Important: The SuperDrive in your MacBook Pro supports standard circular 12 cm discs. Irregularly shaped discs or discs smaller than 12 cm are not supported. Noncircular discs can become lodged in the drive.

Inserting a CD or DVD Disc

To install or use software from a CD or DVD disc:

- 1 With the computer turned on, insert the disc (with the label facing up) into the drive slot until you feel the drive catch the disc and pull it in.

You might need to push the disc nearly all the way in before the drive takes it the rest of the way. This is normal.

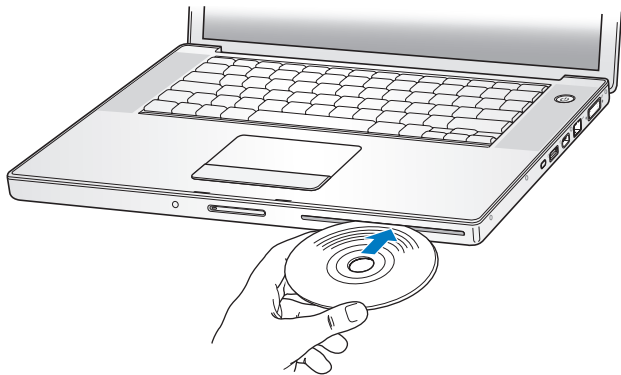

- 2 When the disc icon appears on the desktop, the disc is ready to use.

Ejecting a Disc

To eject a disc, do one of the following:

- Drag the disc icon to the Trash (Eject icon).
- Press and hold the Media Eject (⏏) key on the keyboard until the disc ejects.

Allow the disc to fully eject before removing or reinserting it.

If you can't eject the disc, quit any applications that might be using the disc and try again. If that doesn't work, restart the computer while holding down the trackpad button.

Playing DVDs

To play a DVD-Video disc on your MacBook Pro, insert the DVD. DVD Player opens automatically. You'll find DVD Player provides easy-to-use controls for starting, stopping, and viewing DVDs.



If your MacBook Pro is connected to a TV so that you can watch a DVD-Video on the TV screen, select 720 x 480 NTSC (in the United States) or 720 x 576 PAL (in Europe and other regions) in the Displays pane of System Preferences.

You can easily connect your MacBook Pro to your stereo system. Use a miniplug-to-RCA cable (not included) to connect the headphone (🎧) port on your MacBook Pro to the audio input ports on your stereo.

Recording on CD and DVD Discs

Your MacBook Pro can record data to CD-R and CD-RW discs. You can record your own digital movies on blank recordable DVD-R, DVD-RW, DVD+R, or DVD+RW discs. You can also record other kinds of digital data, such as backing up files onto a recordable DVD disc. Your MacBook Pro can read but not record on DVD-RAM discs.

To record data on CD-R, CD-RW, DVD-R, DVD-RW, DVD+R, or DVD+RW discs:

- 1 Insert a blank recordable CD or DVD disc into the drive.
- 2 In the dialog that appears, enter a name for the disc and select the format you want to use.
- 3 Double-click the disc icon that appears on your desktop, and then drag files and folders to it.
- 4 Click the Burn Disc icon beside the disc name in the Finder sidebar.

You can also record music on CD or DVD discs right from your iTunes library.

To record music from your iTunes library:

- 1 Click the iTunes icon in the Dock.
- 2 Select the playlist or songs you want to record.
- 3 Insert a blank recordable CD or DVD disc.
- 4 At the top of the iTunes window, click Burn CD.

Important: If your battery runs down when you are burning a CD, the burn can fail and you will not be able to use the CD disc again. To prevent this, always use your power adapter when burning a CD.

With applications like iDVD, you can create your own customized digital media project, burn it on a blank recordable disc, and play it on most standard DVD players.

To burn an iDVD project onto a blank DVD-R, DVD-RW, DVD+R, or DVD+RW disc:

- 1 Open iDVD and open your completed iDVD project.
- 2 Click the Burn button.
- 3 When prompted, insert a blank recordable DVD disc into the drive.

4 Click the Burn button again.

For more information, open iDVD and choose Help > iDVD Help.

Important: If your battery runs down when you are burning a DVD, the burn can fail and the DVD disc will not be able to be used again. To prevent this, always use your power adapter when burning a DVD.

Getting More Information

For more information about DVD Player and iTunes, see these resources:

- For instructions about using DVD Player, open DVD Player and choose Help > DVD Player Help from the menu bar.
- For information about how to use iTunes to record music files on a CD or DVD disc, choose Help > “iTunes and Music Store Help” from within iTunes.

Understanding Sudden Motion Sensor Technology

Your MacBook Pro has Sudden Motion Sensor technology, built-in protection for the hard disk that is designed to help prevent disk failures if the computer is dropped or experiences severe vibration.

Sudden Motion Sensor protection does not affect hard disk performance during regular MacBook Pro operation. Occasionally, unusually strong vibrations might activate the Sudden Motion Sensor technology at a time when your MacBook Pro is writing or reading data intensively (such as when playing or recording video or audio). If you notice dropped frames or sound elements, make sure that your MacBook Pro is in a stable environment without vibration or abrupt movement.

Using Your Battery

When the external power adapter is not connected, your computer draws power from its battery. The length of time that you can run your MacBook Pro varies, depending on the applications you use and the external devices connected to your MacBook Pro. Turning off features such as AirPort Extreme or Bluetooth wireless technology can help conserve battery charge. For more information about using your battery, see “Understanding Battery Conservation Tips” on page 79.

You can determine the charge left in your battery by looking at the battery level indicator lights on the battery itself. Press the button next to the lights and the lights glow to show how much charge is left in the battery. The indicator lights remain lit for a few seconds after you press the button. You can check the charge with the battery in or out of your MacBook Pro.

If your battery runs low while you are working, attach your power adapter and let the battery recharge. To replace a low battery with a charged one when you are not connected to a power adapter, it's best to shut down your computer. If you put your MacBook Pro to sleep to replace the battery, wait until the sleep indicator light is pulsating before removing the battery. Although your computer will shut down when you remove the battery, you won't lose any data.

Important: If only one flashing light is on, very little charge is left. If no lights are visible, the battery is completely drained and the computer will not start up unless the power adapter is connected. Plug in the power adapter to let the battery recharge, or replace the drained battery with a fully charged battery (see page 78).

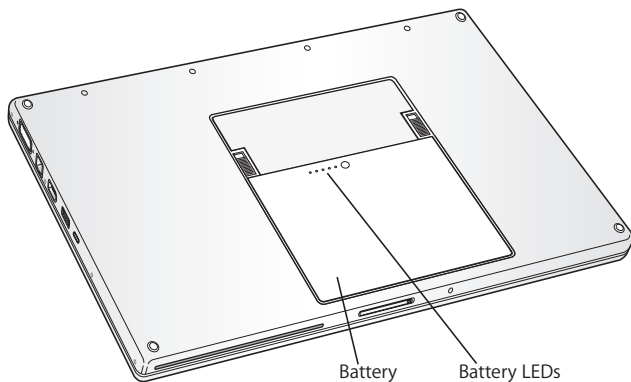

If the battery icon in the Finder menu bar is set to show the percentage of charge, you might sometimes notice that the battery does not attain a full 100 percent charge when the power adapter is attached. This is normal behavior; battery life is maximized if charging is not continuously cycled on and off when the battery's charge capacity is between 95 and 100 percent. When the battery level eventually drops below 95 percent, it will charge all the way to 100 percent.

Removing and Replacing the Battery

For instructions on removing and replacing the battery, see “Installing Additional Memory” on page 84.

Note: Dispose of batteries according to your local environmental laws and guidelines. For more information, see “Disposal and Recycling Information” on page 133.

Charging a Battery

When the power adapter that came with your computer is connected, the battery recharges whether the computer is off, on, or in sleep. However, the battery recharges more quickly if the computer is off or in sleep. When the MacBook Pro is on, you can monitor the battery charge level using the Battery status menu in the menu bar.

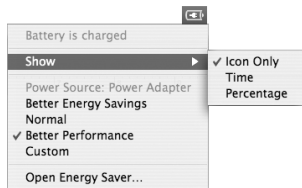

The battery charge level displayed is based on the amount of power left in the battery with the applications, peripheral devices, and system settings (display brightness, Energy Saver settings, and so on) you are currently using. To conserve battery power, close applications and disconnect peripheral devices not in use, and adjust your Energy Saver settings (see the next section).

Understanding Battery Conservation Tips

The amount of work time your MacBook Pro battery can provide before you need to recharge depends on the applications and peripheral devices you're currently using and the steps you take to conserve power while you work.

For the best conservation of battery power, do the following:

- Disconnect bus-powered USB or FireWire devices when they are not in use.

- Turn off AirPort or Bluetooth when they are not in use. (Use the AirPort and Bluetooth status menus in the menu bar. If these icons don't appear in the menu bar, you can turn them on in the Network and Bluetooth panes of System Preferences.)
- Quit open applications that you are not using.
- Remove CD and DVD discs when they are not in use.
- Reduce screen brightness using the brightness controls on the MacBook Pro keyboard.
- Set the hard disk to spin down after a short time. In the Energy Saver pane of System Preferences, select the “Put the hard disk to sleep when possible” option.
- Set your MacBook Pro to sleep after inactivity of five minutes or less.
- Your MacBook Pro is preset to automatically reduce its processing speed during periods of light processing activity when using battery power, thus reducing power usage. The setting that determines this is the Normal option in the Optimization pop-up menu of the Energy Saver pane of System Preferences. During periods of high processing activity, your computer will automatically switch to a higher processing speed. To conserve the most battery life, choose Better Battery Life from the Optimization pop-up menu. Be aware that choosing this option may affect your computer's performance. To set your computer to use its highest processing speed at all times, choose Better Performance.

Getting More Information About Your MacBook Pro Battery

Additional information is available in Mac Help. Choose Help > Mac Help and search for “battery.” You can also find information about extending the life of your battery at www.apple.com/batteries/notebooks.html.

Securing Your MacBook Pro

You can purchase a security cable lock to protect your MacBook Pro. With a lock, you can secure your computer to a desk or table.

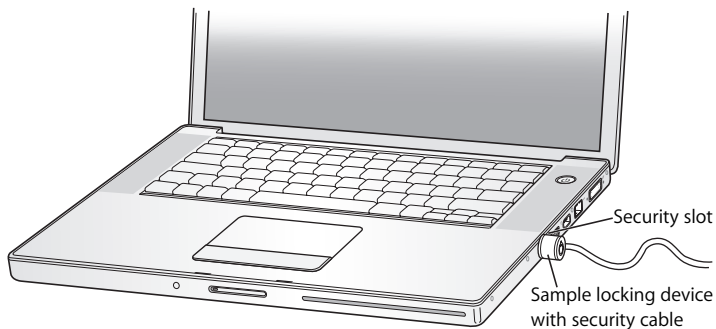

Getting More Information About Security Options

Additional information about the software security features of your MacBook Pro, including multiple user passwords and file encryption, is available in Mac Help. Choose Help > Mac Help and search for “security” or “multiple users.”

Adding Memory to Your MacBook Pro

4

This chapter provides information and instructions for installing additional memory and for removing and replacing the battery in your MacBook Pro.

Warning: Apple recommends that you have an Apple-certified technician install memory. Consult the service and support information that came with your computer for instructions on how to contact Apple for service. If you attempt to install memory and damage your equipment, such damage is not covered by the limited warranty on your computer.

Your computer has two memory slots that you access by removing the memory door in the battery bay. Your MacBook Pro comes with a minimum of 512 megabytes (MB) of 667 MHz Double Data Rate (DDR2) Synchronous Dynamic Random-Access Memory (SDRAM) installed. Both memory slots can accept an SDRAM module that meets the following specifications:

- Double Data Rate Small Outline Dual Inline Memory Module (DDR SO-DIMM) format
- 1.25 inch or smaller
- 512 MB or 1 gigabyte (GB)
- 200-pin

- PC2-5300 DDR2 667 MHz Type RAM

Depending on the configuration of the MacBook Pro you purchased, both memory slots might already be full.

The maximum amount of memory you can install in your MacBook Pro is 2 GB, using 1 GB DIMMs in both memory slots.

Installing Additional Memory

Installing memory involves removing and replacing your battery. The following procedure includes instructions for adding memory and replacing your battery.

Step 1: Removing the Battery

- 1 Shut down your MacBook Pro. Disconnect the power adapter, Ethernet cable, and any other cords connected to the MacBook Pro to prevent damaging the computer.
- 2 Turn over the MacBook Pro and locate the release latches on either side of the battery. Slide both latches up. The battery should pop up slightly. Lift it out.

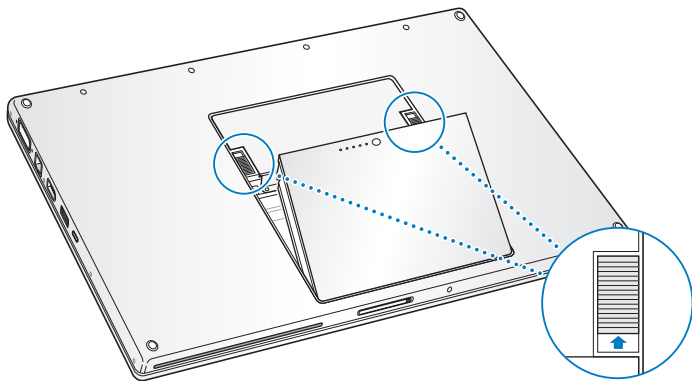

Warning: The internal components of your MacBook Pro can be hot. If you have been using your MacBook Pro, wait 10 minutes after shutting down to let the internal components cool before continuing.

Step 2: Installing Memory

- 1 Using a Phillips size 00 screwdriver, unscrew the memory door and remove it from the battery bay of your computer.

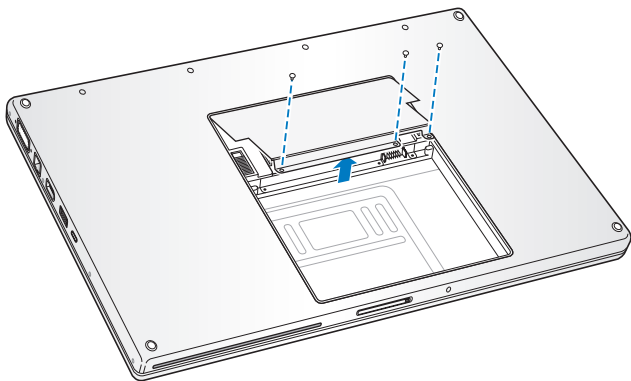

- 2 Touch a metal surface inside the computer to discharge any static electricity from your body.

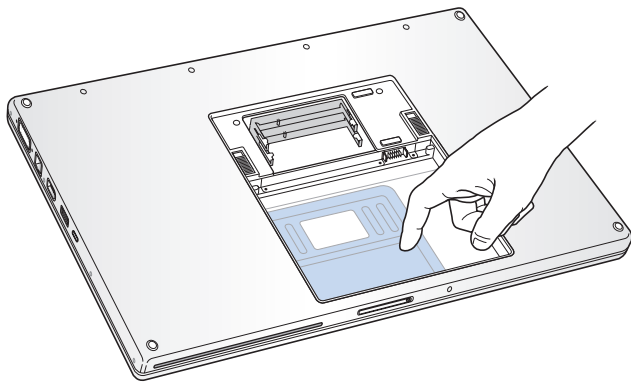

- 3 If you already have a memory card installed in the slot, remove it. Spread the tabs in the slot away from the notches in the memory card. The card should pop up slightly. Lift the memory card to a 25-degree angle and then gently slide the card out of the memory slot.

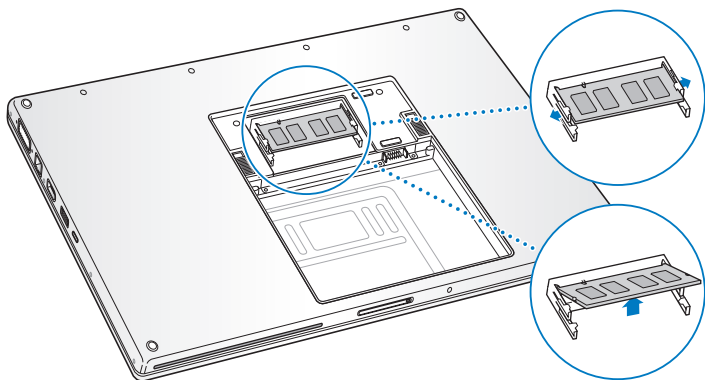

- 4 Insert the memory card at a 25-degree angle. Line up the notch in the card with the small tab in the memory slot and slide the card into the slot until the gold edge is almost invisible. Then firmly push the memory card into the memory slot. You might feel some resistance.

- 5 Gently spread the small tabs in the memory slot away from the notches and push the memory card down until the two snaps on either side of the card lock into place.

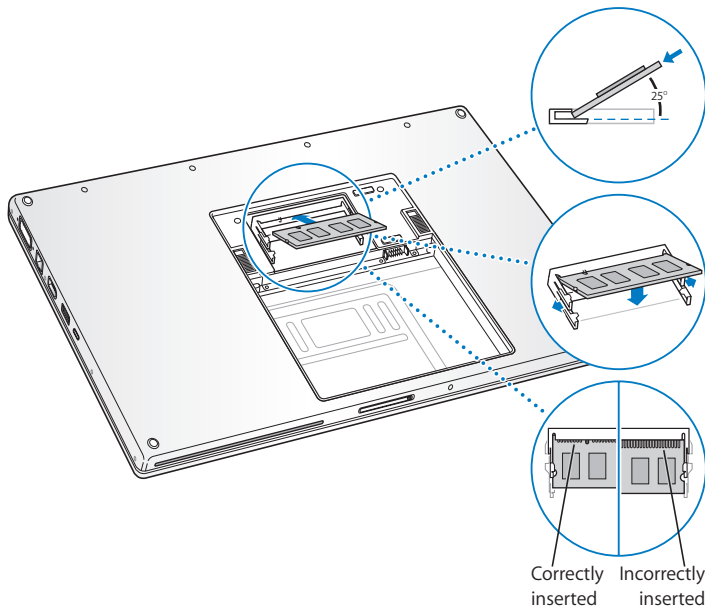

Note: Make sure your memory is installed according to this illustration, where the gold contacts are almost completely inserted into the connector.

- 6 Insert any additional memory in the second slot.
- 7 Replace the memory door and make sure it is lying flat before screwing it into place.

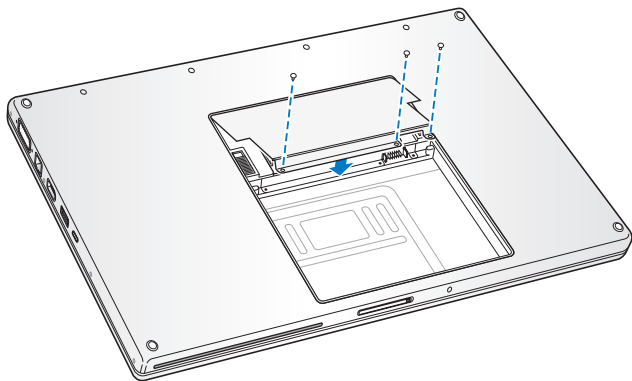

Step 3: Replacing the Battery

- 1 Place the bottom edge of the battery in the battery compartment. Gently press the top edge of the battery down until the battery latch locks into place.

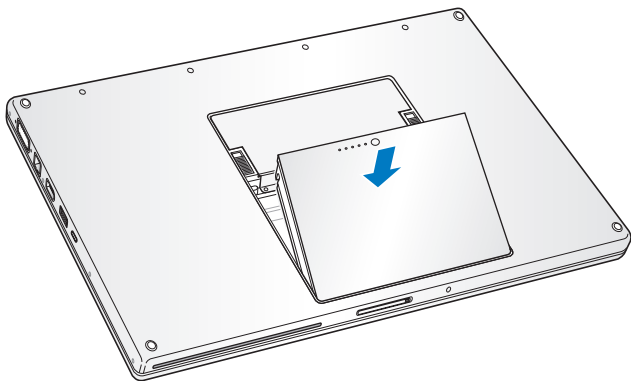

- 2 Reconnect the power adapter and any other cables that were attached.

Making Sure Your MacBook Pro Recognizes the New Memory

After installing additional memory in your MacBook Pro, check whether the computer recognizes the new memory.

To check the computer's memory:

- 1 Start up your computer.
- 2 When you see the Mac OS desktop, choose Apple (🍏) > About This Mac.



— Total memory installed in your MacBook Pro

The total memory includes the amount of memory that originally came with the computer plus the new memory you added. For a detailed breakdown of the amount of memory installed in your computer, open System Profiler by clicking More Info and then Memory.

If your computer doesn't recognize the memory or it doesn't start up correctly, shut down your MacBook Pro and check the instructions again to make sure the memory you installed is compatible with this MacBook Pro and that it is installed correctly. If you still have problems, remove the memory and consult the support information that came with the memory or contact the vendor who provided the memory.

If you have a problem working with your MacBook Pro, check here first for solutions and advice.

When you experience a problem working with your MacBook Pro, there is usually a simple and quick solution. Be aware of the conditions that led up to the problem. Making a note of things you did before the problem occurred will help you narrow down possible causes and then find the answers you need.

Note the following:

- The applications you were using when the problem occurred. Problems that occur only with a specific application might indicate that the application is not compatible with the version of the Mac OS installed on your computer.
- Any software that you recently installed, especially software that added items to the System folder.
- Any new hardware that you installed, such as additional memory or a peripheral.

You can also find more troubleshooting information in Mac Help and on the Apple Service & Support website at www.apple.com/support.

Problems That Prevent You From Using Your Computer

If the computer doesn't respond or the pointer doesn't move

- Press Command (⌘)-Option-Esc to force a frozen application to quit. In the dialog that appears, select the application you would like to quit and click Force Quit. Next, save your work in any open applications and restart the computer to make sure the problem is entirely cleared up.
- If you are unable to force the application to quit, press and hold the power (⏻) button for a few seconds to shut down the computer.
- If the computer still doesn't respond, try to restart it by simultaneously pressing the Command (⌘) and Control keys on your keyboard and the power (⏻) button.

If the problem occurs frequently, choose Help > Mac Help from the menu bar at the top of the screen. Search for the word “freeze” to get help for instances when the computer freezes or doesn't respond.

If the problem occurs only when you use a particular application, check with the application's manufacturer to see if it is compatible with your computer. If you know an application is compatible, you might need to reinstall your computer's system software.

If the computer freezes during startup or you see a flashing question mark or the display is dark and the sleep indicator light is glowing steadily (not in sleep)

- Wait a few seconds. If the computer doesn't start up after a delay, shut down your computer by pressing and holding the power (⏻) button for about 5 seconds, until the computer shuts down. Then hold down the Option key and press the power (⏻) button again to start up your computer. When your computer starts up, click the hard disk icon, and then click the right arrow. After the computer starts up, open System Preferences and click Startup Disk. Select a local Mac OS X System folder.

- If that doesn't work, try using Disk Utility to repair the disk by inserting the Mac OS X Install Disc 1 into your computer. Then restart your computer and hold down the C key as it starts up. Choose Installer > Open Disk Utility. When Disk Utility opens, follow the instructions in the First Aid pane to see if the utility can repair your disk. If using Disk Utility doesn't work, you might need to reinstall your computer's system software. For instructions, see "Reinstalling the Software That Came With Your Computer" on page 99.

If the computer won't turn on or start up

- Make sure the power adapter is plugged into the computer and into a functioning power outlet. Make sure to use the power adapter that came with your computer. If the power adapter stops charging and you don't see the indicator light on the power adapter turn on when you plug in the power cord, try unplugging and replugging the power cord to reset it.
- Check if your battery needs to be recharged. Press the small button on the battery. You should see one to four lights indicating the battery's level of charge. If only one battery level indicator light is flashing, allow the power adapter to charge the battery until at least one indicator light is glowing continuously.
- If the first two suggestions do not solve the problem, return the computer to its factory settings by disconnecting the power adapter, removing the battery, and holding down the power (⏻) button for at least 5 seconds.
- If you recently installed additional memory, make sure that it is correctly installed and that it is compatible with your computer. See whether removing it allows the computer to start up (see "Installing Additional Memory" on page 84).

- If you are still unable to start up your computer, see the service and support information that came with your MacBook Pro for information about contacting Apple for service.

If the display suddenly goes black or your system freezes

Try restarting your system.

- 1 Unplug any devices that are connected to your MacBook Pro except the power adapter.
- 2 Hold down the Command (⌘) and Control keys and press the power (⏻) button to restart the system.
- 3 Let the battery charge to at least 10 percent before plugging in any external devices and resuming your work.

To see how much the battery has recharged, look at the Battery status menu in the menu bar.

Additionally, your display might darken if you have energy saver features set for the battery. For more information, see “Adjusting Your Display” on page 28.

Other Problems

If you forgot your password

You can reset your administrator password and passwords for all other accounts.

- 1 Insert your Mac OS X Install Disc 1. Then restart your computer and hold down the C key as it starts up.
- 2 Choose Installer > Reset Password from the menu bar. Follow the instructions on the screen.

If you have a problem with an application

- For problems with software from a manufacturer other than Apple, contact the manufacturer. Software manufacturers often provide software updates on their websites.
- You can configure your MacBook Pro to automatically check for and install the latest Apple software using the Software Update pane of System Preferences. For more information, choose Help > Mac Help from the menu bar and search for “Software Update.”

Note: Classic (or Mac OS 9) applications are not compatible with your computer and will not open.

If you have trouble using AirPort Extreme wireless communication

- Make sure the computer or network you are trying to connect to is running and has a wireless access point.
- Make sure you are within antenna range of the other computer or the network's access point by checking the AirPort Extreme or AirPort Express signal level. Check the AirPort (📶) status menu in the menu bar. Up to four bars appear, indicating signal strength.

Nearby electronic devices or metal structures can interfere with wireless communication and reduce this range. Repositioning or rotating the computer might improve reception.

- Make sure you have properly configured the software according to the instructions that came with your base station or access point.

- See AirPort Help (choose Help > Mac Help, then choose Library > AirPort Help from the menu bar) and the instructions that came with the wireless device for more information.

If your computer's hard disk is not recording data correctly

- In a few instances, if the hard disk undergoes unusually strong vibration, the Sudden Motion Sensor might become active and cause dropped frames or unrecorded portions of sound or data when the disk is recording intensively. If this occurs, make sure that your MacBook Pro is in a stable environment without vibration or abrupt movement.
- If vibration isn't the problem, run Disk Utility (in Applications/Utilities) to check the drive.

If you have trouble ejecting a disc

- Quit any applications that might be using the disc and try again. If that doesn't work, restart the computer and then immediately press and hold the trackpad button.

If you suspect a problem with your computer hardware

- You can use the Apple Hardware Test application to help determine if there is a problem with one of your computer's components, such as the memory or processor. For more information about Apple Hardware Test, see "Using Apple Hardware Test" on page 101.

If you have problems with your Internet connection

- Make sure your phone line or network cable is connected and functioning properly.
- If you are using a dial-up Internet connection, make sure that your phone cord is plugged into the Apple USB Modem (available separately) and not the Ethernet (↔) port on the computer.

- Open the Network pane of System Preferences and verify the information entered there with your Internet service provider (ISP) or network administrator.

If you have a problem using your computer or working with the Mac OS

- If the answers to your questions are not in this manual, choose Help > Mac Help from the menu bar and search for instructions and troubleshooting information.
- Check the Apple Support website at www.apple.com/support for the latest troubleshooting information and software updates.

Reinstalling the Software That Came With Your Computer

Use the software installation discs that came with your computer to reinstall Mac OS X and any applications that came with your computer.

Important: Apple recommends that you back up the data on your hard disk before reinstalling software. Apple is not responsible for any lost data.

Installing Mac OS X and Applications

To install Mac OS X and the applications that came with your computer, follow these steps:

1 Back up your essential files.

Because the Erase and Install option erases your destination disk, you should back up your essential files before installing Mac OS X and other applications.

2 Make sure your power adapter is plugged in.

3 Insert the Mac OS X Install Disc 1 that came with your computer.

4 Double-click Install Mac OS X and Bundled Software.

5 Follow the onscreen instructions.

- 6 After selecting the destination disk for installation, continue following the onscreen instructions. Your computer might restart and ask you to insert the next Mac OS X installation disc.

Note: To restore Mac OS X on your computer to the original factory settings, click Options in the Select a Destination pane of the Installer, and then select Erase and Install.

After selecting the destination disk for installation, continue following the onscreen instructions for a basic installation of Mac OS X. To install custom applications, click Customize, click the triangle next to the application, and select the application that matches your language.

Installing Applications

To install just the applications that came with your computer, follow the steps below. Your computer must have Mac OS X already installed.

- 1 Back up your essential files.
- 2 Make sure your power adapter is plugged in.
- 3 Insert the Mac OS X Install Disc 1 that came with your computer.
- 4 Double-click Install Bundled Software Only.
- 5 Follow the onscreen instructions.
- 6 After selecting the destination disk for installation, continue following the onscreen instructions. Your computer might restart and ask you to insert the next Mac OS X installation disc.

Note: To install iCal, iChat AV, iSync, iTunes, Safari, and the iLife applications, follow the instructions in “Installing Mac OS X and Applications” on page 99. You might need to insert the Mac OS X Disc 2, depending on the applications you select to install.

Using Apple Hardware Test

You can use Apple Hardware Test to help determine if there is a problem with your computer’s hardware.

To use Apple Hardware Test:

- 1 Disconnect all external devices from your computer except the power adapter. If you have an Ethernet cable connected, disconnect it.
- 2 Insert the Mac OS X Install Disc 1 that came with your computer.
- 3 Restart your computer and hold down the D key as it starts up.
- 4 When the Apple Hardware Test main screen appears, follow the onscreen instructions.
- 5 If Apple Hardware Test detects a problem, it displays an error code. Make a note of the error code before pursuing support options. If Apple Hardware Test does not detect a hardware failure, the problem might be software related.

For more information about Apple Hardware Test, see the Apple Hardware Test Read Me file on the Mac OS X Install Disc 1.

Installing Xcode Tools

To install just the Xcode Tools, which are intended for software developers to use, follow these steps:

- 1 Insert the Mac OS X Install Disc 1 that came with your computer.
- 2 Double-click Xcode Tools.
- 3 Double-click XcodeTools.mpkg.
- 4 Follow the onscreen instructions.

Locating Your Product Serial Number

You can see your computer's serial number by choosing Apple (🍏) > About This Mac and then clicking the More Info button, or by opening System Profiler (in Applications/Utilities) and clicking Hardware. The serial number for your MacBook Pro is also located in the battery bay. For information about removing the battery, see "Installing Additional Memory" on page 84.

Specifications

A

You can use System Profiler to find out detailed information about your MacBook Pro.

You can find out the amount of built-in memory, hard disk size, devices connected, and the product serial number. To access the information in System Profiler, choose Apple () > About This Mac from the menu bar and then click More Info, or open System Profiler, located in Applications/Utilities.

Click the triangles in the window to show and hide information in the different categories.

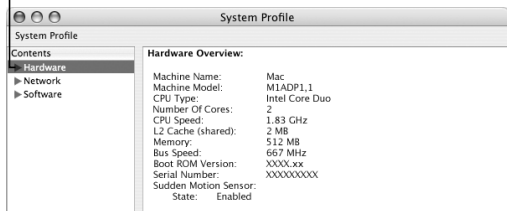

Operating Environment

- Operating temperature: 50° F to 95° F (10° C to 35° C)
- Altitude: 3048 m (10,000 ft.) maximum
- Relative humidity: 0% to 90% noncondensing

Power Adapter

- Input: AC 100–240 volts (V), 50/60 hertz (Hz)
- Output: DC 18.5 V @ 4.6 A; 16.5 V @ 3.6 A

Battery

- Output: DC 10.8 V
- Capacity: 60 Wh

Additional information is available on the Internet at www.apple.com/macbookpro and www.apple.com/support.

Safety, Use, and Care Information

B

Read this important MacBook Pro safety and maintenance information.

Apple products are designed and evaluated to the latest standards for safety of information technology equipment. However, to ensure safe usage, it is important that safety instructions marked on the product and in the documentation are followed.

Understanding General Safety Instructions

Read and follow all instructions marked on the product and in this manual before operating your MacBook Pro. Keep these instructions handy for reference by you and others.

- Set up your MacBook Pro on a stable work surface.
- Keep your computer away from sources of liquids, such as drinks, washbasins, bathtubs, shower stalls, and so on.
- Protect your computer from dampness or wet weather, such as rain, snow, and fog.
- For your own safety and that of your equipment, always take the following precautions. Disconnect the power plug (by pulling the plug, not the cord), remove the battery, and disconnect the phone cord if any of the following conditions exists:
 - You want to install memory.

- You want to remove any parts.
- The power cord or plug becomes frayed or otherwise damaged.
- You spill something into the case.
- Your computer is exposed to rain or any other excess moisture.
- Your computer has been dropped or the case has been otherwise damaged.
- You suspect that your computer needs service or repair.
- You want to clean the case (use only the recommended procedure described later).
- The MacBook Pro power adapter port contains a magnet. Do not place magnetically sensitive material or devices within 1 inch (25 mm) of this port.
- Never push objects of any kind into the MacBook Pro ventilation openings.
- Use caution when handling the battery. There is risk of explosion if the battery is replaced by an incorrect type. Dispose of used batteries according to your local environmental guidelines. Don't puncture, drop, or incinerate the battery.

Setting Up Your MacBook Pro and Power Adapter

Ensure the AC plug or AC power cord is fully inserted into the power adapter before plugging the adapter into a power outlet. For best results, connect the adapter using the AC power cord and use a grounded power outlet.

Use only the power adapter that came with your MacBook Pro. Adapters for other electronic devices (including other MacBook Pro models and other portable computers) might look similar, but they can negatively affect your computer's performance or damage your computer.

The power adapter may become hot during normal use of your MacBook Pro. Always allow adequate ventilation around the adapter and use care when handling during or immediately after operation.

Never force a connector into a port. Check for obstructions on the port. If the connector and port don't join with reasonable ease, they probably don't match. Make sure that the connector matches the port and that you have positioned the connector correctly in relation to the port.

If debris gets into the power adapter port, it can prevent the power adapter from seating properly. Remove debris gently with a cotton swab.

Using Your MacBook Pro

When you're using your MacBook Pro or charging the battery, it is normal for the bottom of the case to get warm. For prolonged use, place your MacBook Pro on a flat, stable surface.

Do not leave the bottom of your MacBook Pro in contact with your lap or any surface of your body for extended periods. Prolonged contact with your body could cause discomfort and potentially a burn.

The bottom of the MacBook Pro case functions as a cooling surface that transfers heat from inside the computer to the cooler air outside. The bottom of the case is raised slightly to allow airflow that keeps the unit within normal operating temperatures. In addition, warm air is vented from the slots in the back of the case.

Warning: Do not place your MacBook Pro on a pillow or other soft material when it is on, as the material can block the airflow vents, in particular the rear vents, and cause the computer to overheat. Never place anything over your keyboard when operating in closed-lid mode. This can cause your computer to cycle on and off which might create excessive heat and drain your battery. Never turn on your computer unless all of its internal and external parts are in place. Operating the computer when it is open or missing parts can be dangerous and can damage your computer.

Carrying Your MacBook Pro

If you carry your MacBook Pro in a bag or briefcase, make sure that there are no loose items (such as paper clips or coins) that could accidentally get inside the computer through an opening such as the optical drive slot or get stuck inside a port.

Storing Your MacBook Pro

If you are going to store your MacBook Pro for an extended period of time, keep it in a cool location (ideally, 71° F or 22° C) and do one of the following to preserve your MacBook Pro battery life:

- Discharge the battery 50 percent before storing your MacBook Pro.
- When storing your computer for longer than five months, discharge the battery to approximately 50 percent and then remove it from the MacBook Pro. If you are storing your computer for an extended period, recharge your battery to 50 percent every six months or so.

Cleaning Your MacBook Pro

Follow these general rules when cleaning the outside of your computer and its components:

- Shut down your MacBook Pro, unplug the power adapter, and remove the battery.
- Use a damp, soft, lint-free cloth to clean the computer's exterior. Avoid getting moisture in any openings. Do not spray liquid directly on the computer.
- Don't use aerosol sprays, solvents, or abrasives.

Cleaning Your MacBook Pro Display

To clean your MacBook Pro screen, do the following:

- Shut down your MacBook Pro, unplug the power adapter, and remove the battery.
- Dampen a clean, soft, lint-free cloth or paper with water only and wipe the screen. Do not spray liquid directly on the screen.

Avoiding Hearing Damage

Warning: Permanent hearing loss may occur if earbuds or headphones are used at high volume. You can adapt over time to a higher volume of sound that may sound normal but can be damaging to your hearing. If you experience ringing in your ears or muffled speech, stop listening and have your hearing checked. The louder the volume, the less time is required before your hearing could be affected. Hearing experts suggest that to protect your hearing:

- Limit the amount of time you use earbuds or headphones at high volume.
- Avoid turning up the volume to block out noisy surroundings.
- Turn the volume down if you can't hear people speaking near you.

Understanding Ergonomics

Here are some tips for setting up a healthy work environment.

Keyboard and Trackpad

When you use the keyboard and trackpad, your shoulders should be relaxed. Your upper arm and forearm should form an angle that is slightly greater than a right angle, with your wrist and hand in roughly a straight line.

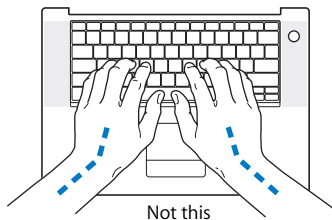
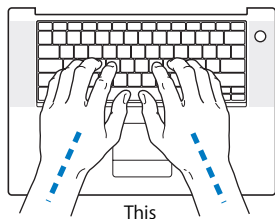

Use a light touch when typing or using the trackpad and keep your hands and fingers relaxed. Avoid rolling your thumbs under your palms.

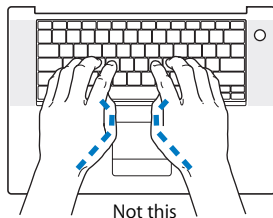
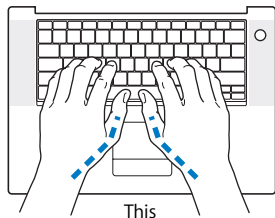

Change hand positions often to avoid fatigue. Some computer users might develop discomfort in their hands, wrists, or arms after intensive work without breaks. If you begin to develop chronic pain or discomfort in your hands, wrists, or arms, consult a qualified health specialist.

Chair

An adjustable chair that provides firm, comfortable support is best. Adjust the height of the chair so your thighs are horizontal and your feet flat on the floor. The back of the chair should support your lower back (lumbar region). Follow the manufacturer's instructions for adjusting the backrest to fit your body properly.

You might have to raise your chair so that your forearms and hands are at the proper angle to the keyboard. If this makes it impossible to rest your feet flat on the floor, you can use a footrest with adjustable height and tilt to make up for any gap between the floor and your feet. Or you might lower the desktop to eliminate the need for a footrest. Another option is to use a desk with a keyboard tray that's lower than the regular work surface.

External Mouse

If you use an external mouse, position the mouse at the same height as your keyboard and within a comfortable reach.

Built-in Display

Adjust the angle of the display to minimize glare and reflections from overhead lights and windows. Do not force the display if you meet resistance. The display is not meant to open more than 120 degrees.

You can adjust the brightness of the screen when you take the computer from one work location to another, or if the lighting in your work area changes.

Getting More Information

Go to www.apple.com/about/ergonomics.

Apple and the Environment

Apple Computer, Inc., recognizes its responsibility to minimize the environmental impacts of its operations and products. For more information, go to www.apple.com/environment/summary.html.

Connecting to the Internet

C

You can use your computer to browse the World Wide Web, send email to friends and family, and chat in real time over the Internet. Use this information to help you connect to the Internet.

When you first start up Mac OS X, Setup Assistant helps you enter your Internet configuration information. If you didn't use Setup Assistant to configure your Internet connection, you can use Network Setup Assistant later (see "Using Network Setup Assistant to Connect" on page 119). If you don't want to use Network Setup Assistant, you can use the information in this appendix to set up your connection manually.

There are four kinds of Internet connections:

- **High-speed DSL or cable modem connection:** Your computer is plugged into a special modem you get from an ISP using an Ethernet cable.
- **AirPort Extreme wireless connection:** Your computer is connected wirelessly to the Internet using an AirPort Extreme Base Station or AirPort Express.
- **Local area network (LAN):** Your computer is plugged into a LAN using an Ethernet cable. This type of connection is usually used in the workplace.

- **Dial-up connection:** Your computer is connected to an external modem that is plugged into a phone wall jack using a phone cable.

Before you connect to the Internet:

- 1 Set up an account with an Internet service provider (ISP).
- 2 Gather the connection information you need from your ISP or network administrator. See the next section, “Gathering the Information You Need,” to find out what information to get for each type of connection. You can write the information directly on the next few pages, and then enter it in Setup Assistant.

If another computer in the same location is already connected to the Internet, you might be able to use its settings.

To find the settings on a Mac OS X computer:

- Open the Network pane of System Preferences.
- Choose your connection method from the Show pop-up menu.
- Copy the information for your configuration.

To find the settings on a Windows PC:

The connection information on a Windows computer resides in two places.

- *To find the IP address and subnet mask*, open the “Network and Internet Connections” control panel.
 - *To find user account information*, open the User Accounts control panel.
- 3 If you are using an external modem, plug the Apple USB Modem (available separately) into a USB port on your MacBook Pro, and then use a phone cord (not included) to connect the modem to a phone wall jack. If you are using a DSL or cable modem, follow the instructions that came with the modem to connect it to your computer.

- 4 Turn on your computer and enter information in Setup Assistant to configure your Internet connection.

Note: If you already started up your computer and did not use Setup Assistant to configure your Internet connection, see “Using Network Setup Assistant to Connect” on page 119.

Gathering the Information You Need

You can write the information you get from your ISP, your network administrator, or your other computer on these pages, and then enter it in Network Setup Assistant.

To set up a phone dial-up connection, gather the following information:

- Service provider name
- User or account name
- Password
- ISP phone number
- Alternate phone number
- Dialing prefix to obtain an outside line

To set up a DSL modem, cable modem, LAN, or AirPort Extreme wireless connection, choose your connection method (ask your administrator or your ISP, if you don't know):

- Manually
- Using DHCP with a manual address
- Using DHCP
- Using BootP
- PPP

If you're unsure which method to use, "Using DHCP" might be a good choice, because the network supplies most of the required information for you automatically.

If you selected "Manually" or "Using DHCP with a manual address," gather the following:

- IP address
- Subnet mask
- Router address

Note: If you selected "Using DHCP with a manual address," you don't need a subnet mask or router address.

If you selected "Using DHCP," gather the following optional information (ask your ISP whether you need it):

- DHCP client ID
- DNS servers

If you selected “PPP” (for PPPoE connection), gather the following:

- Service provider
- Account name
- Password
- PPPoE service name

The information below might be optional. Ask your ISP or system administrator whether you need it.

- DNS servers
- Domain name
- Proxy server

Entering Your Information

After gathering your specific setup information from your ISP or network administrator, you can use Network Setup Assistant to connect or enter the information manually.

Using Network Setup Assistant to Connect

If you didn't use Setup Assistant to configure your Internet settings when you first started up your MacBook Pro, you can use Network Setup Assistant at any time to configure your Internet connection or to change your settings.

To use Network Assistant:

- 1 Choose Apple (🍏) > System Preferences.
- 2 Click Network and then click “Assist me.”
- 3 Click Assistant to open Network Assistant.

4 Follow the onscreen instructions.

More information about setting up an Internet connection is available in Mac Help. Choose Help > Mac Help and search for “connecting to the Internet.”

Manually Entering Information

To enter your information manually:

- 1 Open System Preferences > Network.
- 2 Select from the Show pop-up menu and set options according to the type of connection you want to make:
 - Cable modem, DSL, or LAN connection using one of these configurations:
 - **Manually:** With a manual configuration, your ISP or network administrator provides a static IP address and other information that you enter in Network preferences.
 - **Using Dynamic Host Configuration Protocol (DHCP):** With a DHCP configuration, the DHCP server automatically enters the information for you.
 - **Using Point-to-Point Protocol over Ethernet (PPPoE):** If you use a DSL modem and need a user name and password to connect to the Internet, check with your ISP to determine if you should connect using PPPoE.
 - Dial-up external modem with Point-to-Point Protocol (PPP) connection. Enter your account name and password, telephone number, and other information.
 - AirPort Extreme wireless connection: You can configure your AirPort Extreme network and Internet connection using AirPort Setup Assistant, located in the Application/Utilities folder.
- 3 If you need further help, click “Assist me”.

Troubleshooting Your Connection

If you have trouble with your Internet connection, you can try the steps in this section for your type of connection or you can use Network Diagnostics.

To use Network Diagnostics:

- 1 Choose Apple (🍏) > System Preferences.
- 2 Click Network and then click “Assist me.”
- 3 Click Diagnostics to open Network Diagnostics.
- 4 Follow the onscreen instructions.

If Network Diagnostics can't resolve the problem, there may be a problem with the Internet service provider (ISP) you are trying to connect to, with an external device you are using to connect to your ISP, or with the server you are trying to access. You can also try the following steps.

Cable Modem, DSL, and LAN Internet Connections

If you can't connect to the Internet using your cable modem, DSL, or local area network (LAN), see the following instructions.

Important: Instructions that refer to modems do not apply to LAN users. LAN users might have hubs, switches, routers, or connection pods that cable and DSL modem users do not. LAN users should contact their network administrator rather than an ISP.

Check the cables and power supplies

Make sure all modem cables are firmly plugged in, including the modem power cord, the cable from the modem to the computer, and the cable from the modem to the wall jack. Check the cables and power supplies to Ethernet hubs and routers.

Turn the modem off and on and reset the modem hardware

Cycle the power on your DSL or cable modem by turning it off for a few minutes and then turning it back on. Some ISPs recommend that you unplug the modem's power cord. If your modem has a reset button, you can press it either before or after cycling the power.

PPPoE Connections

If you are unable to connect to your ISP using PPPoE, first check the cables and power supplies, and then turn the modem off and on again and reset the modem hardware.

To check System Preferences settings:

- 1 Choose Apple (🍏) > System Preferences from the menu bar.
- 2 Click Network.
- 3 Choose Network Port Configurations from the Show pop-up menu.
- 4 Drag Built-in Ethernet to the top of the Port Configurations list.
- 5 Choose Built-in Ethernet from the Show pop-up menu.
- 6 Click PPPoE.
- 7 Select "Connect using PPPoE."
- 8 Check the Account Name field to be sure you have entered the correct information from your ISP.
- 9 If you chose to save your password, retype it to make sure it is correct.
- 10 Click TCP/IP. Make sure you've entered the correct information from your ISP in this pane.
- 11 Click Apply Now.

Network Connections

If you have two or more computers attempting to share an Internet connection, be sure that your network is set up properly. You need to know if your ISP provides only one IP address or if it provides multiple IP addresses, one for each computer.

If only one IP address is used, then you must have a router capable of sharing the connection, also known as network address translation (NAT) or “IP masquerading.” For setup information, check the documentation provided with your router or ask the person who set up your network. The AirPort Extreme Base Station can be used to share one IP address among multiple computers. For information about using the AirPort Extreme Base Station, check the onscreen help or visit the Apple AirPort website at www.apple.com/airport.

If you cannot resolve the issue using these steps, contact your ISP.

Top Ten Questions

D

Do you have a question? Here are the top ten questions commonly asked by new MacBook Pro users.

My Internet connection doesn't seem to be working. How do I set it up?

There are different types of Internet connections. For example, you can connect using a modem, a DSL connection, a wireless AirPort connection, or an Ethernet network. You will need to supply Mac OS X with specific information about your connection type, Internet service provider, or network. The first step in configuring your connection is gathering the information needed for your connection type. To find out what information you need and for instructions on how to configure your connection type, see Appendix C, "Connecting to the Internet," on page 115. Your computer also has the Setup Assistant application to help walk you through setting up an Internet connection. Open System Preferences and click Network. Click the "Assist me" button to open Network Setup Assistant.

How do I set up my printer? Is it compatible with my MacBook Pro?

Begin by connecting your printer and installing any software according to the instructions that came with your printer. Next, open System Preferences and click the Print & Fax icon. Use the Print & Fax pane to configure your MacBook Pro to access the printer. You'll find lots of information about setting up printers in Mac Help (choose Help > Mac Help from the menu bar and search for "printer"). Also see "Connecting to a Printer" on page 48 of this manual.

If your printer doesn't seem to be working as expected, you might need to check the manufacturer's website for updated print drivers. Often the latest printer software is available for downloading.

If you sent a print job to your printer but it's not printing, check to see if the print job is stopped or on hold by clicking the printer icon in the Dock. (If no icon appears in the Dock, open Printer Setup Utility in the Applications/Utilities folder and double-click the printer's name.) If the window for the printer says "Job Stopped," click the Start Jobs button. If "Hold" appears beside the job name, resume printing by selecting the job name and clicking Resume. If a print job has stopped printing because of a technical error, you can delete the faulty job by selecting the job and clicking Delete. You can then try printing the job again.

How does the Mac OS X interface work?

Users new to Mac OS X often have questions about how to carry out certain tasks. Your best source for Mac OS X information is Mac Help. You'll find introductory explanations for new users, users switching from Windows computers, and users upgrading from Mac OS 9. Open Mac Help by choosing Help > Mac Help from the Help menu in the menu bar at the top of your screen. Browse the new Mac OS X user information listed there. Many of the basic tasks users are interested in involve the Finder, so try searching for "Finder," too.

How do I make my MacBook Pro battery last longer?

Remember to calibrate your battery when you first use it (see "Calibrating Your Battery" on page 24). You can conserve battery power by using the Energy Saver preference pane to specify how quickly the computer should go to sleep or dim the display. Open System Preferences and click the Energy Saver icon. Choose settings that are optimized for your type of usage. Using peripheral devices such as hard disks, which get power from your computer, can also shorten the amount of time your battery lasts. You can conserve battery power by disconnecting such devices. You can also purchase an additional battery that you can swap into your computer when power gets low. For more information about conserving battery power, see "Understanding Battery Conservation Tips" on page 79.

I put a disc in my optical drive, but nothing happened. How do I know if the disc is compatible with my optical drive?

Press the Media Eject (⏏) key to eject the disc. Apple slot-loading optical drives support only round 12 cm discs. Nonstandard discs and discs with noncircular shapes do not work in the optical drive. For more information about nonstandard discs, go to the Apple Service & Support website at www.apple.com/support and search for “nonstandard discs.”

Warning: Inserting a nonstandard disc into the optical drive can damage the drive.

How do I connect an external display, TV, or projector with a DVI connection to my MacBook Pro?

- 1 Turn on the external display or projector.
- 2 Make sure the display cable is connected to the external projector or display.
- 3 Connect the display cable to your MacBook Pro. Your MacBook Pro automatically detects the external display.
- 4 Adjust the resolution on the external display by using the Displays pane of System Preferences or the Displays status menu in the menu bar.

Note: Use the Apple DVI to Video Adapter, available separately, to display content on your TV.

To connect an external display or projector with a VGA connection to your computer:

- 1 Turn on the external display or projector.
- 2 Make sure the display cable is connected to the external projector or display.
- 3 Connect the DVI to VGA adapter that came with your MacBook Pro to the VGA connector of the external display or projector, and then connect the adapter to your MacBook Pro.

Your MacBook Pro automatically detects the external display.

- 4 Adjust the resolution on the external display by using the Displays pane of System Preferences or the Displays status menu in the menu bar.

I forgot my password. How do I reset it?

To reset your password, start up from the software install and restore disc that came with your computer. After the installer opens, choose Installer > Reset Password from the menu bar. Follow the instructions on the screen.

I hear a fan coming on and my MacBook Pro seems to get quite warm. Is that OK?

As your MacBook Pro operates, it's designed to keep itself within safe thermal limits. The fan comes on and stays on to keep the MacBook Pro operating at normal temperatures. The bottom of your MacBook Pro can become warm because it's designed to let heat dissipate through the case. This is normal. For more information, see "Using Your MacBook Pro" on page 107.

My application or Mac OS X doesn't seem to be working correctly. Do I need to reinstall Mac OS X?

The process of troubleshooting a problem requires that you answer several questions, such as whether a problem always happens with a specific application, is related to your operating system, or is a result of faulty hardware. Before you reinstall, see “Troubleshooting” on page 93 to help analyze the problem. Apple also provides many technical explanations and advice for solving problems on the Apple Service & Support website at www.apple.com/support. If you determine that you must reinstall Mac OS X, you'll find instructions in “Reinstalling the Software That Came With Your Computer” on page 99.

I installed an application on my MacBook Pro, but it doesn't seem to be working. Where can I go for help?

Check the documentation that came with the application for instructions on how to get support. Often manufacturers are aware of common problems that might occur with their applications and provide solutions and updates for immediate use. If your application is not an Apple product, you'll need to contact the manufacturer directly for the best support.

Communications Regulation Information

Compliance Statement

This device complies with part 15 of the FCC rules. Operation is subject to the following two conditions: (1) This device may not cause harmful interference, and (2) this device must accept any interference received, including interference that may cause undesired operation. See instructions if interference to radio or television reception is suspected.

L'utilisation de ce dispositif est autorisée seulement aux conditions suivantes : (1) il ne doit pas produire de brouillage et (2) l'utilisateur du dispositif doit être prêt à accepter tout brouillage radioélectrique reçu, même si ce brouillage est susceptible de compromettre le fonctionnement du dispositif.

Radio and Television Interference

This computer equipment generates, uses, and can radiate radio-frequency energy. If it is not installed and used properly—that is, in strict accordance with Apple's instructions—it may cause interference with radio and television reception.

This equipment has been tested and found to comply with the limits for a Class B digital device in accordance with the specifications in Part 15 of FCC rules. These specifications are designed to provide reasonable protection against such interference in a residential installation. However, there is no guarantee that interference will not occur in a particular installation.

You can determine whether your computer system is causing interference by turning it off. If the interference stops, it was probably caused by the computer or one of the peripheral devices.

If your computer system does cause interference to radio or television reception, try to correct the interference by using one or more of the following measures:

- Turn the television or radio antenna until the interference stops.
- Move the computer to one side or the other of the television or radio.
- Move the computer farther away from the television or radio.
- Plug the computer into an outlet that is on a different circuit from the television or radio. (That is, make certain the computer and the television or radio are on circuits controlled by different circuit breakers or fuses.)

If necessary, consult an Apple-authorized service provider or Apple. See the service and support information that came with your Apple product. Or, consult an experienced radio/television technician for additional suggestions.

Important: Changes or modifications to this product not authorized by Apple Computer, Inc., could void the EMC compliance and negate your authority to operate the product.

This product has demonstrated EMC compliance under conditions that included the use of compliant peripheral devices and shielded cables between system components. It is important that you use compliant peripheral devices and shielded cables between system components to reduce the possibility of causing interference to radios, television sets, and other electronic devices.

Responsible party (contact for FCC matters only): Apple Computer, Inc. Product Compliance, 1 Infinite Loop M/S 26-A, Cupertino, CA 95014-2084, 408-974-2000.

Wireless Radio Use

This device is restricted to indoor use due to its operation in the 5.15 to 5.25 GHz frequency range to reduce the potential for harmful interference to co-channel Mobile Satellite systems.

Cet appareil doit être utilisé à l'intérieur.

Exposure to Radio Frequency Energy

The radiated output power of the AirPort Extreme technology is below the FCC radio frequency exposure limits. Nevertheless, it is advised to use the wireless equipment in such a manner that the potential for human contact during normal operation is minimized.

FCC Bluetooth Wireless Compliance

The antenna used with this transmitter must not be colocated or operated in conjunction with any other antenna or transmitter subject to the conditions of the FCC Grant.

Bluetooth Industry Canada Statement

This Class B device meets all requirements of the Canadian interference-causing equipment regulations.

Cet appareil numérique de la Class B respecte toutes les exigences du Règlement sur le matériel brouilleur du Canada.

Industry Canada Statement

Complies with the Canadian ICES-003 Class B specifications. Cet appareil numérique de la classe B est conforme à la norme NMB-003 du Canada. This device complies with RSS 210 of Industry Canada.

Bluetooth Europe–EU Declaration of Conformity

This wireless device complies with the specifications EN 300 328, EN 301-489, and EN 60950 following the provisions of the R&TTE Directive.

Europe - EU Declaration of Conformity

The equipment complies with the RF Exposure Requirement 1999/519/EC, Council Recommendation of 12 July 1999 on the limitation of exposure of the general public to electromagnetic fields (0 Hz to 300 GHz. This equipment meets the following conformance standards: EN300 328, EN301 893, EN301 489-17, EN60950

Hereby, Apple Computer, Inc., declares that this 802.11a/b/g Mini-PCle card is in compliance with the essential requirements and other relevant provisions of Directive 1999/5/EC.

Complies with European Directives 72/23/EEC, 89/336/EEC, 1999/5/EC

See <http://www.apple.com/euro/compliance/>

Korea Statements

"당해 무선설비는 운용 중 전파혼신 가능성이 있음"

B급 기기 (가정용 정보통신기기)

이 기기는 가정용으로 전자파적합등록을 한 기기로서 주거지역에서는 물론 모든 지역에서 사용할 수 있습니다.

Singapore Wireless Certification

Complies with
IDA Standards
DB00063

Taiwan Wireless Statements

於 2.4GHz 區域內操作之 無線設備之警告聲明

經型式認證合格之低功率射頻電機，非經許可，公司、商號或使用者均不得擅自變更頻率，加大功率或變更原設計之特性及功能。低功率射頻電機之使用不得影響飛航安全及干擾合法通信；經發現有干擾現象時，應立即停用，並改善至無干擾時方得繼續使用。前項合法通信指依電信法規定作業之無線電通信。低功率射頻電機須忍受合法通信或工業、科學及醫療用電波輻射性電機設備之干擾。

於 5.25GHz 至 5.35GHz 區域內操作之 無線設備之警告聲明

工作頻率 5.250 ~ 5.350GHz 該頻段限於室內使用。

Taiwan Class B Statement

Class B 設備之警告聲明
NIL

VCCI Class B Statement

情報処理装置等電波障害自主規制について

この装置は、情報処理装置等電波障害自主規制協議会 (VCCI) の基準に基づくクラス B 情報技術装置です。この装置は家庭環境で使用されることを目的としていますが、この装置がラジオやテレビジョン受信機に近接して使用されると、受信障害を引き起こすことがあります。

取扱説明書に従って正しい取扱をしてください。

External USB Modem Information

When connecting your MacBook Pro to the phone line using an external USB modem, refer to the telecommunications agency information in the documentation that came with your modem.

ENERGY STAR® Compliance

As an ENERGY STAR® partner, Apple has determined that standard configurations of this product meet the ENERGY STAR® guidelines for energy efficiency. The ENERGY STAR® program is a partnership with office product equipment manufacturers to promote energy-efficiency. Reducing energy consumption of office products saves money and reduces pollution by eliminating wasted energy.

Disposal and Recycling Information

The backlight lamp in this product contains mercury. Dispose according to local, state, and federal laws. For information about Apple's recycling program, go to www.apple.com/environment/summary.html.

Battery Disposal Information

Dispose of batteries according to your local environmental laws and guidelines.

Deutschland: Das Gerät enthält Batterien. Diese gehören nicht in den Hausmüll. Sie können verbrauchte Batterien beim Handel oder bei den Kommunen unentgeltlich abgeben. Um Kurzschlüsse zu vermeiden, kleben Sie die Pole der Batterien vorsorglich mit einem Klebestreifen ab.

Nederlands: Gebruikte batterijen kunnen worden ingeleverd bij de chemokar of in een speciale batterijcontainer voor klein chemisch afval (kca) worden gedeponeerd.



Taiwan:



廢電池請回收

European Union—Disposal Information:



The symbol above means that according to local laws and regulations your product should be disposed of separately from household waste. When this product reaches its end of life, take it to a collection point designated by local authorities. Some collection points accept products for free. The separate collection and recycling of your product at the time of disposal will help conserve natural resources and ensure that it is recycled in a manner that protects human health and the environment.

Index

A

- about your battery 24
- AC plug 8, 9, 30
- AC power adapter. *See* power adapter
- AC power cord 9, 30
- adjusting your display 28
- AirPort Express 62
- AirPort Extreme
 - problems 97
 - setting up a
 - connection 118, 120
 - technology 62
- ALS system 28, 33
- amber light 30
- ambient light sensing (ALS) system 28, 33
- Appearance preferences 45
- Apple Remote
 - delete pairing 36
 - keyboard equivalents 38
 - overview 35
 - pairing the remote 36
 - replacing the battery 37

- turning off IR 38
 - using 35
- application freeze 47
- applications 46
- audio line in port 21

B

- battery
 - calibrating 24
 - charging 79
 - conserving power 79, 127
 - disposal 78, 133
 - general information 77
 - indicator lights 77
 - power 79
 - removing 84
 - replacing 91
 - storing 108
 - tips 79
- blinking question mark 13
- Bluetooth preferences 65, 80
- Bluetooth technology 64
- brightness controls 19
- built-in speakers 17, 71
- built-in video camera. *See* iSight

- burning DVDs 75
- button, power 11, 17

C

- cable modem, setting up 118
- calibrating your battery 24
- camera. *See* iSight
- carrying your MacBook Pro 108
- CDs 72
- changing
 - image size 29
 - password 96
 - System Preferences 45
 - the desktop 45
 - the screen resolution 29
- charging the battery 79
- checking memory 91
- cleaning
 - your display 109
 - your MacBook Pro 109
- closed display 69
- computer
 - freezes 94
 - won't turn on 95

- connecting
 - Bluetooth enabled devices 64
 - a cable modem 10
 - a DSL modem 10
 - to an Ethernet network 10
 - an external display 69
 - external devices 54
 - FireWire devices 57
 - flat-panel display 71
 - headphones 49
 - to the Internet 15
 - a monitor or TV 128
 - a printer 48
 - a projector 69
 - a TV 70
 - two computers 58, 60
 - USB printers 54
 - a VCR 70
 - a video device 70
 - video cameras 57
 - wirelessly 62
- conserving battery power 127
- controls
 - brightness 19
 - keyboard 19
 - volume 19
- cord, AC power 9

D

- Dashboard 19, 44
- Dashboard & Exposé
 - preferences 45
- default resolution 29
- Desktop & Screen Saver
 - preferences 46
- DHCP. *See* Dynamic Host Configuration Protocol
- dial-up modem 120
- dim display 29
- discs, compatible 128
- display
 - cleaning 109
 - default resolution 29
 - dim 29
 - Energy Saver options 28
 - goes black 96
 - mirroring 68
 - release button 17
- Displays pane 29
- disposing of batteries 78, 133
- Dock 43, 46
- Dock preferences 46
- downloading software 47
- DSL modem 118
- dual-display mode 68
- DVD
 - burning 75
 - discs 74
- DVI port 67

- DVI to VGA adapter 67
- Dynamic Host Configuration Protocol (DHCP) 120

E

- ejecting a disc 73, 98
- Energy Saver preferences 28, 80
- environment 113
- ergonomics 111
- Ethernet
 - cables 66
 - networking capability 66
 - port 21, 66
- Exposé 19, 34, 44
- ExpressCards
 - ejecting 62
 - inserting 62
 - slot 21, 61
- external monitor 68
- external monitor port 21

F

- F11 key 19
- F12 key 19
- fan noise 129
- FireWire
 - cable 58, 60
 - devices and battery power 59
 - port 21, 57
 - Target Disk Mode 58, 60

Force Quit 47
frozen application 47
function key 19

G

general safety 105
green light 30

H

hand positions 111
hard disk 98
headphone
 jack 71
 port 21, 71
heat 107, 129
Hi-Speed USB 21

I

iChat
 buddy icon 42
 help 41
 using built-in iSight 39
 videoconferencing 41
image size 29
iMovie HD 40
infrared receiver. *See* IR
inserting a disc 73
installation instructions
 additional RAM 84
 applications 100
 Mac OS X 100
 memory 84

Internet
 connecting to 15
 connecting using Setup
 Assistant 120
 connection problems 98,
 125
 connection problems 98,
 125
IP address, sharing 123
IR
 receiver 17, 35
 turning off reception 38
iSight
 indicator light 17
 turning off 42
 using 39
 using with iMovie HD 40
 using with Photo Booth 39
 video camera 17
 videoconferencing 41

K

keeping the display closed 69
keyboard
 illumination 33
 illumination controls 19

L

LAN connection 118, 120

M

Mac OS X
 interface 127
 learning about 44

manually using DHCP router
 option 118
Media Eject key 19
memory
 checking 91
 installing 84
 screwdriver required 86
 specifications 84
microphone 17, 71
mirroring 68
modem
 cable 115
 DSL 115
monitoring printing 49
mouse 34
multiple USB devices 56
Mute control 19
muting your computer 19

N

Network Diagnostics 121
Network preferences 80
Network Setup Assistant 115
networking
 two computers 58, 60
 wirelessly 62
Num Lock key 19
number, serial 102
numeric keypad 33

O

operating system 44

optical digital audio out
port 21

optical drive
about 17
compatible discs 128
disc sizes supported 72

P

password, resetting 96, 129

Photo Booth 39

playing
CDs 72
DVD-Video discs 74

plug, AC 8, 9, 30

Point-to-Point Protocol
(PPP) 120

port
audio line in 21
DVI 21
Ethernet 21
external monitor 21
FireWire 21
headphone 21, 71
power adapter 21
USB 21

power adapter
plugging in 106
port 21
using 30

power button 11, 17

PPP. *See* Point-to-Point Protocol

PPPoE connections 119, 122

presentation mode. *See* display
mirroring

Print & Fax preferences 48, 49

print monitoring 49

printing setup 49

problems

computer freezes 94

computer won't
respond 94

computer won't turn on 95

display goes black 96

hard disk 98

Internet connection 98, 121

pointer won't move 94

PPPoE connections 122

trouble ejecting a disc 98

trouble using AirPort 97

turning the computer on 13
with an application 97
See also troubleshooting

putting your MacBook Pro to
sleep 22

R

RAM 84

recording
CD-R 75
CD-RW 75
DVD 74
music 75

reinstalling software 99, 130

remote. *See* Apple Remote

removing the battery 84

replacing the battery 91

resetting your password 96,
129

S

safety
general instructions 105
power adapter 106
using your
MacBook Pro 107

screwdriver 86

scrolling trackpad feature 32

SDRAM specifications 83

security slot 21, 81

serial number, finding 102

setting up
Internet connection 118
a printer 49
printer (tips) 126
to connect manually 119

Setup Assistant 14

shutting down 23

sleep
indicator light 17
mode 22

slot-loading optical drive 17

Software Update 47

speakers 17, 71

Spotlight 44

Startup Disk preferences 58

- stopping
 - an application 47
 - the computer 23
- storing your MacBook Pro 108
- Sudden Motion Sensor 76
- SuperDrive 72
- System Preferences 45
 - Appearance 45
 - Bluetooth 65, 80
 - Dashboard & Exposé 45
 - Desktop & Screen Saver 46
 - Dock 46
 - Energy Saver 80
 - Energy Saver
 - preferences 22
 - Network 80
 - Print & Fax 48
 - Software Update 48
 - Startup Disk 58
 - turning off IR reception 38

T

- telephone dial-up
 - connection 117

- trackpad
 - described 17
 - scrolling 32
 - tips 31, 32
 - using 11
- transferring
 - files or documents 50
 - information 58, 60
- troubleshooting
 - AirPort 97
 - an application 97
 - computer freezes 94
 - computer won't respond 94
 - computer won't turn on 95
 - display goes black 96
 - ejecting a disc 98
 - hard disk 98
 - Internet connection 98, 121
 - pointer won't move 94
- turning on your
 - MacBook Pro 11
- typing position 111

U

- Universal Serial Bus. *See* USB
- updating software 47
- USB
 - devices and battery
 - power 55
 - hubs 56
 - multiple devices 56
 - ports 21, 54

V

- VGA connection 69, 129
- video camera indicator light 17
- video mirroring 68
- Video Mode Toggle key 19
- video, capturing 40
- video, playing 74
- videoconferencing 41
- volume controls 19

W

- waking your computer 22
- wireless connections 62

