

New Jersey Institute of Technology Digital Commons @ NJIT

Dissertations

Theses and Dissertations

Spring 2012

Advanced intelligent control and optimization for cardiac pacemaker systems

Wei Shi

New Jersey Institute of Technology

Follow this and additional works at: <https://digitalcommons.njit.edu/dissertations>



Part of the [Electrical and Electronics Commons](#)

Recommended Citation

Shi, Wei, "Advanced intelligent control and optimization for cardiac pacemaker systems" (2012). *Dissertations*. 306.
<https://digitalcommons.njit.edu/dissertations/306>

This Dissertation is brought to you for free and open access by the Theses and Dissertations at Digital Commons @ NJIT. It has been accepted for inclusion in Dissertations by an authorized administrator of Digital Commons @ NJIT. For more information, please contact digitalcommons@njit.edu.

Copyright Warning & Restrictions

The copyright law of the United States (Title 17, United States Code) governs the making of photocopies or other reproductions of copyrighted material.

Under certain conditions specified in the law, libraries and archives are authorized to furnish a photocopy or other reproduction. One of these specified conditions is that the photocopy or reproduction is not to be “used for any purpose other than private study, scholarship, or research.” If a user makes a request for, or later uses, a photocopy or reproduction for purposes in excess of “fair use” that user may be liable for copyright infringement,

This institution reserves the right to refuse to accept a copying order if, in its judgment, fulfillment of the order would involve violation of copyright law.

Please Note: The author retains the copyright while the New Jersey Institute of Technology reserves the right to distribute this thesis or dissertation

Printing note: If you do not wish to print this page, then select “Pages from: first page # to: last page #” on the print dialog screen

The Van Houten library has removed some of the personal information and all signatures from the approval page and biographical sketches of theses and dissertations in order to protect the identity of NJIT graduates and faculty.

ABSTRACT

ADVANCED INTELLIGENT CONTROL AND OPTIMIZATION FOR CARDIAC PACEMAKER SYSTEMS

**by
Wei Shi**

Since cardiovascular diseases are major causes of morbidity and mortality in the developed countries and the number one cause of death in the United States, their accurate diagnosis and effective treatment via advanced cardiac pacemaker systems have become very important. Intelligent control and optimization of the pacemakers are significant research subjects. Serious but infrequently occurring arrhythmias are difficult to diagnose. The use of electrocardiogram (ECG) waveform only cannot exactly distinguish between deadly abnormalities and temporary arrhythmias. Thus, this work develops a new method based on frequency entrainment to analyze pole-zero characteristics of the phase error between abnormal ECG and entrained Yanagihara, Noma, and Irisawa (YNI)-response. The thresholds of poles and zeros to diagnose deadly bradycardia and tachycardia are derived, respectively, for the first time. For bradycardia under different states, a fuzzy proportional-integral-derivative (FPID) controller for dual-sensor cardiac pacemaker systems is designed. It can automatically control the heart rate to accurately track a desired preset profile. Through comparing with the conventional algorithm, FPID provides a more suitable control strategy for offering better adaptation of the heart rate, in order to fulfill the patient's physiological needs. This novel control method improves the robustness and performance of a pacemaker system significantly.

Higher delivered energy for stimulation may cause higher energy consumption in pacemakers and accelerated battery depletion. Hence, this work designs an optimal

single-pulse stimulus to treat sudden cardiac arrest, while minimizing the pulse amplitude and releasing stimulus pain. Moreover, it derives the minimum pulse amplitude for successful entrainment. The simulation results confirm that the optimal single-pulse is effective to induce rapid response of sudden cardiac arrest for heartbeat recovery, while a significant reduction in the delivered energy is achieved. The study will be helpful for not only better diagnosis and treatment of cardiovascular diseases but also improving the performance of pacemaker systems.

**ADVANCED INTELLIGENT CONTROL AND OPTIMIZATION
FOR CARDIAC PACEMAKER SYSTEMS**

**by
Wei Shi**

**A Dissertation
Submitted to the Faculty of
New Jersey Institute of Technology
in Partial Fulfillment of the Requirements for the Degree of
Doctor of Philosophy in Electrical Engineering**

Department of Electrical and Computer Engineering

May 2012

Copyright © 2012 by Wei Shi

ALL RIGHTS RESERVED

APPROVAL PAGE

**ADVANCED INTELLIGENT CONTROL AND OPTIMIZATION
FOR CARDIAC PACEMAKER SYSTEMS**

Wei Shi

Dr. MengChu Zhou, Dissertation Advisor Date
Professor of Electrical and Computer Engineering, NJIT

Dr. John D. Carpinelli, Committee Member Date
Professor of Electrical and Computer Engineering, NJIT

Dr. Sui-Hoi Edwin Hou, Committee Member Date
Associate Professor of Electrical and Computer Engineering, NJIT

Dr. Zhiming Ji, Committee Member Date
Associate Professor of Mechanical Engineering, NJIT

Dr. Yun-Qing Shi, Committee Member Date
Professor of Electrical and Computer Engineering, NJIT

BIOGRAPHICAL SKETCH

Author: Wei Shi
Degree: Doctor of Philosophy
Date: May 2012

Undergraduate and Graduate Education:

- Doctor of Philosophy in Electrical Engineering, New Jersey Institute of Technology, Newark, NJ, 2012
- Master of Science in Electrical Engineering, Hebei University of Technology, Tianjin, P. R. China, 2008
- Bachelor of Science in Electrical Engineering, Nanjing University of Aeronautics and Astronautics, Nanjing, P. R. China, 2005

Major: Electrical Engineering

Publications:

- Shi, W.V., & Zhou, M.C. (2011). Optimal single-pulse for pacemakers based on a sinoatrial model. *IEEE/ASME Transactions on Mechatronics*, in press.
- Shi, W.V., & Zhou, M.C. (2011). Body sensors applied in pacemakers: A survey. *IEEE Sensors Journal*, in press.
- Shi, W.V., & Zhou, M.C. (2011). Fuzzy PID controllers for dual-sensor pacing systems in patients with bradycardias at rest. *Proc. IEEE Int. Conf. Systems, Man and Cybernetics*, Alaska, USA, 1117-1122.
- Shi, W.V., & Zhou, M.C. (2011). Recent advances of sensors for pacemakers. *Proc. IEEE Int. Conf. Network., Sens. Control*, Delft, The Netherlands, 520-525.
- Shi, W.V., Chang, T.N., & Zhou, M.C. (2010). Method to detect cardiac abnormalities based on electrocardiography and sinoatrial pacemaker model. *Proc. IEEE Int. Conf. Mechatron. Autom.*, Xi'an, China, 566-571.

Shi, W., & Zhang, F.M. (2007). Application of iFIX in chemical manufacture process.
Journal of Industrial Control Computer, 11, 76-77.

To my beloved family

ACKNOWLEDGMENT

This dissertation could not have been written without Dr. MengChu Zhou, who not only served as my research advisor, providing me valuable and countless resources, insight, and intuition, but also constantly gave me support, encouragement, and reassurance. Special thanks are given to Dr. John D. Carpinelli, Dr. Edwin Hou, Dr. Zhiming Ji, and Dr. Yun-Qing Shi for actively participating in my committee.

Also, I'd like to thank Dr. Timothy N. Chang for his support and suggestions during my Ph.D. studies, and my fellow graduate students in the Real-time Control Laboratory, Biao Cheng and Jing Yang, for their help over the years.

Lastly, but not least important, my sincere thanks go to my family, who gave me coverage and confidence when I was frustrated. Without their love, support and affection, this undertaking might not have been possible.

TABLE OF CONTENTS

Chapter	Page
1 INTRODUCTION	1
1.1 Objectives	1
1.2 Background	4
1.3 Organization of the Dissertation	6
2 LITERATURE REVIEW	8
2.1 Human Heart and Cardiovascular Diseases.....	8
2.2 Cardiac Pacemaker Systems	9
2.2.1 Introduction	9
2.2.2 Basic Functions of Pacemakers	11
2.2.3 History of Development	12
2.2.4 New Features in Modern Pacemakers	17
2.3 Biosensors in Modern Pacemaker Systems	19
2.3.1 Activity Sensors	21
2.3.2 QT Interval.....	24
2.3.3 Dual Sensors	25
2.3.4 Minute Ventilation	26
2.3.5 Other Biosensors.....	27
2.3.6 Future Development	30
2.4 Fuzzy PID Controller for Cardiac Pacemaker Systems	30

TABLE OF CONTENTS
(Continued)

Chapter	Page
3 DIAGNOSIS OF CARDIAC ABNORMALITIES	36
3.1 Mathematical Model of Human Heart.....	36
3.2 Diagnosis of Cardiac Abnormalities.....	41
3.2.1 Introduction	41
3.2.2 Frequency Entrainment	42
3.3 Simulation and Analysis	43
3.3.1 Entrained YNI Model.....	43
3.3.2 Pole-zero Analysis of Phase Error.....	47
3.4 Summary	52
4 FUZZY PID CONTROLLERS FOR DUAL-SENSOR CARDIAC PACEMAKER SYSTEMS	53
4.1 Rate Regulation with Dual-Sensors.....	54
4.2 Conventional Control Scheme	55
4.3 Fuzzy PID Controllers for Dual-Sensor Cardiac Pacemaker Systems.....	57
4.3.1 Design of FPID Controllers	57
4.3.2 FPID Control Rules and Membership Functions	59
4.4 Case Studies and Simulation Results	64
4.5 Summary.....	75
5 OPTIMAL SINGLE-PULSE FOR PACEMAKERS	76
5.1 Introduction	76
5.2 Algorithm Design	77

TABLE OF CONTENTS
(Continued)

Chapter	Page
5.3 Optimal Single-Pulse and Simulation Results	80
5.3.1 Optimal Single-Pulse	80
5.3.2 Simulation Results and Analysis	85
5.4 Summary	89
6 CONCLUSIONS AND FUTURE WORK	90
6.1 Contributions	90
6.2 Limitations	91
6.3 Future Work	92
REFERENCES	94

LIST OF TABLES

Table	Page
2.1 Categories of Sensors for Pacemaker Systems.....	21
2.2 Features of Main Biosensors	28
3.1 Pole-zero Analysis in Different Cases.....	50
4.1 Fuzzy Rule Bases of the FPID System	60
4.2 Meaning of the Linguistic Variables	61
4.3 Individual Characteristics of Particular Patients	65
4.4 Comparison of Simulation Results between the Novel FPID Controller and Conventional Fuzzy Control Algorithm in Case I.....	72
4.5 Comparison of Simulation Results between the Novel FPID Controller and Conventional Fuzzy Control Algorithm in Case II.....	72
4.6 Comparison of Simulation Results between the Novel FPID Controller and Conventional Fuzzy Control Algorithm in Case III.....	73
4.7 Comparison of Simulation Results between the Novel FPID Controller and Conventional Fuzzy Control Algorithm in Case IV.....	74
5.1 Electrical Parameters and Energy of Optimal Single-Pulse.....	88
5.2 Comparisons between Optimal Single-Pulse and Conventional Pulse Settings in Autocapture System	88

LIST OF FIGURES

Figure	Page
2.1 A pacemaker system	10
2.2 A modern pacemaker	11
2.3 Accelerometer sensing system.....	23
3.1 Electrical circuit model of the cell membrane.....	37
3.2 The normal ECG	44
3.3 The normal-entrained YNI-response	44
3.4 The bradycardia ECG	45
3.5 The bradycardia-entrained YNI-response	46
3.6 The tachycardia ECG	46
3.7 The tachycardia-entrained YNI-response	46
3.8 The normal phase error	47
3.9 The bradycardia phase error	48
3.10 The tachycardia phase error	48
3.11 The pole-zero plot of normocardia, bradycardia and tachycardia	51
4.1 The design of fuzzy PID controller for dual-sensor cardiac pacemaker systems	58
4.2 The membership functions	63
4.3 The heart rate tracking for Case I	66
4.4 The heart rate tracking for Case II	67
4.5 The heart rate tracking for Case III.....	69

**LIST OF FIGURES
(Continued)**

Figure	Page
4.6 The heart rate tracking for Case IV	70
5.1 YNI-response under sudden cardiac arrest	78
5.2 YNI-response in recovery from sudden cardiac arrest by single-pulse frequency entrainment	78
5.3 Unsuccessful entrainment under $V_P < V_{Pmin}$	79
5.4 YNI-response frequency entrained by optimized single-pulse, while $V_P = V_{Pmin}$ $= 179.8$ mV	86
5.5 YNI-response frequency entrained by optimized single-pulse, while $V_P = V_{Pmin}$ $= 197.8$ mV	86
5.6 YNI-response frequency entrained by optimized single-pulse, while $V_P = V_{Pmin}$ $= 215.8$ mV	87
5.7 YNI-response unsuccessful frequency entrainment, while $V_P < V_{Pmin}$	87

CHAPTER 1

INTRODUCTION

The explosive growth of research in the field of intelligent control is expected to lead breakthroughs in the areas of biotechnology, bioelectronics and medical devices. Among these areas, accurate diagnosis, effective treatment and optimized devices play a critical role in achieving successful progress. This chapter presents the objectives of this study in Section 1.1, an overview of the implantable medical devices and background of cardiac pacemaker systems in Section 1.2. The organization of the dissertation is presented in Section 1.3.

1.1 Objectives

Cardiovascular diseases are major causes of mortality and morbidity in the developed countries. Early diagnosis and medical treatment of heart diseases can effectively prevent the sudden death of a patient. Thus, this study aims at selecting a human heart model among the existing ones, and designing intelligent control and optimization algorithms to diagnose deadly abnormalities under which a pacemaker needs to be fired, to regulate heart rate automatically, to monitor real-time cardiac activities, and to recover the abnormal to normal heartbeat with minimum delivered energy and stimulus pain.

First, many problems exist regarding pacemakers in a number of conditions. One of them is the diagnosis of cardiac abnormalities in a pacemaker. This is because serious but infrequently occurring arrhythmias are difficult to detect and analyze. Furthermore, it cannot be easily distinguished exactly between deadly abnormalities and temporary

arrhythmias by using only ECG (electrocardiogram) signals. To solve these problems, various types of sensors have been used in previous works. Because no single sensor can fulfill all the requirements of an ideal sensor, the trend is to combine various sensors. The resulting combined sensing system requires a complicated lead system to work and consumes high energy in a pacemaker. Thus, in order to replace the conventional combined sensors, this study develops a diagnostic system that ably utilizes the ECG signals and a human heart model to detect deadly cardiac abnormalities and analyze the threshold condition to adjust a pacemaker. Frequency entrainment based on ECG signals and the heart model is implemented in this work. Instead of a high-cost and complicated multiple-sensor-system, a novel strategy that detects the pole-zero characteristics among normocardia, bradycardia, and tachycardia, is introduced to achieve a diagnostic pacemaker system for the determination of cardiac abnormalities. The thresholds of poles and zeros to diagnose bradycardia and tachycardia are derived for the first time.

Second, to cope with fuzzy or imprecise information of the physiological demand, fuzzy logic controllers for the pacemaker systems have been developed in the existing research. However, the conventional control algorithm needs much improvement to achieve better adaptation of regulating the pacing rate to meet the physiological requirement for each particular patient. In addition, the mathematical complexity in nonlinear fuzzy control makes the formulation of a tuning mechanism an extremely complex problem.

Therefore, the combination of input variables with scaling factor of a PID controller and fuzzy control mechanism for the dual-sensor cardiac pacemaker systems in patients with bradycardias is proposed in this work. Against the conventional fuzzy

control scheme, the fuzzy proportional-integral-derivative (FPID) controller in a closed-loop system determines the optimal pacing rate, automatically regulates the heart rate (HR) to track a desired preset HR profile for each particular patient more accurately and offers an adaptive tuning mechanism.

Finally, in case of cardiac arrest, the electrical signals generated by the heart itself are ineffective to cause a loss of pulse, lower heartbeat, and even annihilation that can result in death within minutes, unless it is interrupted by an external stimulus generated by a pacemaker. Hence, effective treatment and recovery of sudden cardiac arrest is also an important topic in the research of pacemakers. Since pacemaker battery life is principally dependent on energy consumption, higher delivered energy for stimulation causes higher energy consumption in pacemakers and accelerates battery depletion. Meanwhile, fast battery depletion necessitates pulse generator replacements frequently for patients with implantable pacemakers. Moreover, due to the downsizing of pacemaker devices, the reduction of battery size, and the implementation of more sophisticated diagnostic features, continuous efforts have been made to reduce delivered energy and prolong the battery life.

For this problem, an optimization strategy for designing a single-pulse stimulus in pacemakers is proposed in this work, in order to recover heartbeat from sudden cardiac arrest and discover the way to reduce delivered energy for stimulation. While the optimization of such single-pulse is proposed and derived theoretically, it does serve at least three very useful purposes. Firstly, the proposed optimal single-pulse stimulus results in substantial energy savings and extended battery longevity markedly; therefore, patients would require fewer pulse generator replacements. Also, lower pulse amplitude

releases the stimuli pain on patients. Secondly, it produces additional testable predictions, especially compared against the conventional pulse settings. It can strengthen the acceptance of this optimal single-pulse as a useful generic tool for the stimulus. Thirdly, the algorithm of the optimal single-pulse suggests future directions and opportunities for improving medical devices, such as pacemakers.

Hence, this work intends to advance the intelligent control and optimization of cardiac pacemaker systems in the following areas:

1. Frequency entrainment,
2. Pole-zero analysis,
3. Fuzzy PID control, and
4. Optimal single-pulse design algorithm

1.2 Background

The major causes of morbidity and mortality in the developed countries are still cardiac abnormalities, such as bradycardia and cardiac arrest. Thus, in order to prevent the sudden death of a patient, early and accurate diagnosis and medical treatment of heart diseases are very important. For diagnosing heart diseases, one of the proven ways is to use electrocardiogram (ECG) signals, which is a very popular, simple, and noninvasive medical examination. Its result records the electrical activity of a patient's heart. The electrical activity associated with the contractions of heart muscles gives rise to the familiar ECG waveform.

With heart diseases being still the number one cause of death in the United States, the development and improvement of medical devices is of great importance. It is well

known that a pacemaker as one of the implantable cardiac devices for the medical treatment of heart diseases is widely used nowadays. It is a medical device that uses electrical impulses, delivered by electrodes contacting the heart muscles, to regulate the beating of the heart. It can help a person who has an abnormal heart rhythm resume a more active lifestyle.

The first model of heart activities of a single isolated rabbit SA node was developed from the multi-cellular Noble and Noble peripheral model (Demir et al., 1994), (Noble et al., 1984), (Noble et al., 1989). Wilders et al. (Wilders et al., 1991) published a model of single SA nodal cell activities based on single cell experimental data on cell dimensions and membrane capacitance. However, there were no universally-accepted mathematical models to illustrate the activities of a heart until the YNI (Yanagihara, Noma, and Irisawa) model was proposed (Yanagihara et al., 1980). The model has become the most widely used model of action potential behavior for SA nodal cells since 1980.

By contrasting other SA nodal cell models, the YNI model is an established and accurate sinoatrial model of the generation and propagation of the action potentials in the heart. For quantitative investigations, numerical simulations of the activity of cardiac sinoatrial cells are performed by using an YNI model that is a more physiologically relevant model than others.

Modern pacemakers are externally programmable and allow cardiologists to select the optimal pacing modes for individual patients. The complexity and reliability of modern pacemakers have increased significantly, mainly due to developments in sensing technologies. For the purpose of heart rate regulation, various types of sensors, such as

activity sensor, metabolic sensor and dual-sensors, have been employed in pacemakers to detect the heart rate and body activity, and measure some consequence of a physiological change during exercise or facing environmental or emotional changes. Therefore, modern pacemakers with sensors are applied not only for pacing but also for other functions such as obtaining diagnostic data and providing continuous cardiac monitoring and long-term trended clinical information.

1.3 Organization of the Dissertation

This first chapter presents an overview of cardiac pacemaker systems, cardiac abnormalities, and modern pacing systems. It also presents the objective and some background information of this work.

Chapter 2 offers a review of the relevant literature. It begins with the introduction of the human heart, cardiovascular diseases, and cardiac pacemaker systems. Then, biosensors used in modern pacing systems are investigated. In Chapter 3, the mathematical model of a human heart is introduced. The frequency entrainment and pole-zero analysis method are implemented to diagnose deadly cardiac abnormalities under which a pacemaker has to be fired. The related theoretical derivations and simulation results are also illustrated in this chapter.

Chapter 4 introduces the design, modeling and control of dual-sensor cardiac pacemaker systems. Fuzzy logic control and PID control are combined to regulate the heart rate automatically. The conventional control scheme is described and compared with the proposed FPID controllers. The simulation results are discussed at the end of this chapter. In Chapter 5, an optimal single-pulse stimulus in pacemakers for treating sudden

cardiac arrest is designed, while the pulse amplitude is minimized and the delivered energy is reduced. This work develops the frequency entrainment between irregular YNI-response and proposed single-pulse, and derives the minimum amplitude of the optimal single-pulse for successful entrainment. Finally, Chapter 6 summarizes the contributions, discusses the limitations, and indicates the future research directions.

CHAPTER 2

LITERATURE REVIEW

2.1 Human Heart and Cardiovascular Diseases

A human heart is a myogenic muscular organ with a circulatory system, which is responsible for pumping blood throughout the blood vessels by repeated, rhythmic contractions (Okada et al., 2005), (Park et al., 2010). These contraction signals stimulate the heart muscles that generate a regular heartbeat, which is determined primarily by the frequency of contraction and controlled by the rate of discharge of cardiac cells in the right atrial chamber, called a sinoatrial (SA) node.

The SA node is the primary natural pacemaker of a heart that located in the right atrium. It generates electrical signals throughout the rest of the heart's conduction system. Loss of the ability to increase heart rate in response to the demands of physical exertion has predictable adverse consequences on human exercise capacity and quality of life. Particularly, because the normal circulation of blood ceases due to the failure of contraction, sudden cardiac arrest occurs and sometimes results in the shortness of breath, fainting, and even death if there is no effective treatment of external stimulation from implantable medical devices.

Cardiovascular diseases are major causes of morbidity and mortality in the developed countries. They rank the number one cause of death in the United States (Dutta et al., 2005), (Neumar et al., 2010). Heart rate abnormalities include bradycardia, tachycardia and cardiac arrest. Bradycardia is defined as a heart rate less than 60 bpm (beats per minute) although it is seldom symptomatic until the rate drops below 50 bpm when a human is at total rest. It may cause heart attacks in some patients or cardiac arrest.

This occurs because people with bradycardia may not be pumping enough oxygen to their own heart causing heart attack-like symptoms. Besides, a rate greater than 100 bpm in an average adult is defined as tachycardia.

Specifically, the risk of sudden cardiac arrest, which is the cessation of normal circulation of the blood due to failure of the heart to contract effectively, hovers menacingly over patients (Anderson, 2005), (Cakmakci et al., 2009), (Zemiti et al., 2008). As one of the leading causes of sudden cardiac death, cardiac arrest strikes people to death without any forebode, whether or not patients have a diagnosed heart condition. Ventricular fibrillation is the most common cause of cardiac arrest. It occurs when the normal, regular, electrical activation of heart muscle contraction is replaced by chaotic electrical activity that causes the heart to stop beating and pumping blood to the brain and other parts of the body.

Cardiac arrest may result in ineffective electrical signals in the heart and a loss of pulse. Ultimately, low heartbeat and annihilation can cause death within minutes, unless it is interrupted by an external stimulus generated by implantable cardiac devices, such as pacemakers, and then a normal heartbeat is quickly restored (Holzer et al., 2005), (Safar et al., 1996). Hence, effective treatment and recovery of sudden cardiac arrest play an important role in the research of cardiac pacemaker systems.

2.2 Cardiac Pacemaker Systems

2.2.1 Introduction

Cardiac pacemakers have become a therapeutic tool used worldwide with more than 250,000 pacemaker implants every year (Haddad et al., 2006). Pacemakers are responsible for treating arrhythmias of heartbeat, providing electric pulse to mimic the natural pacing system of the heart, maintaining an adequate heart rate by delivering controlled, rhythmic electrical stimuli to the chambers of the heart, and preventing human from being harmed by low heart rate and sudden cardiac arrest (Petrutiu et al., 2007). If the SA node is diseased or the conduction system becomes blocked, the pacemaker takes over control of the rate. A diagram of a pacemaker system is shown in Figure 2.1. The pacemaker is placed under the skin below the collarbone. Wires are placed through the blood vessel beneath the collarbone to the heart and are connected to the pacemaker (Wood & Ellenbogen, 2002).

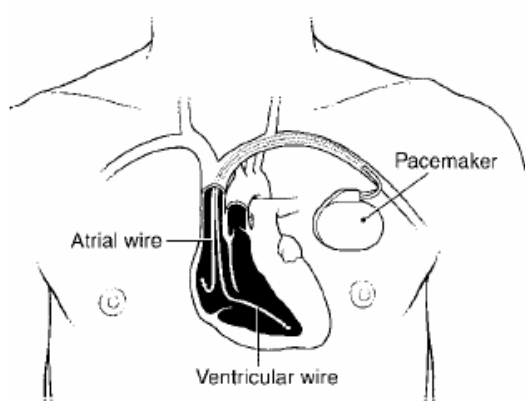

Figure 2.1 A pacemaker system (Wood & Ellenbogen, 2002).

Since the first pacemaker was introduced in 1932 (Greatbatch et al., 1991), much has changed and will continue to change in the future. Early pacemakers were simple, two-transistor, fixed-rate stimulators weighing more than 180 g. In contrast, modern pacemakers, as shown in Figure 2.2, are externally programmable and allow cardiologists to select the optimal pacing modes for individual patients. The complexity and reliability of modern pacemakers have increased significantly, mainly due to developments in sensing technologies. Meanwhile, such complicated systems consume high energy and shorten the longevity of the pacemaker battery (Shepard et al., 2009). For serious and sudden occurring arrhythmias and sudden cardiac arrest, if the pulse delivered by a pacemaker is not with the optimal amplitude and energy, it may result in non-effective stimuli delivery or waste of energy. Therefore, modern pacemakers with biosensors are applied not only for pacing but also for other functions such as obtaining diagnostic data, and providing continuous cardiac monitoring and long-term trended clinical information.



Figure 2.2 A modern pacemaker.

Source: Wikipedia, Artificial pacemaker. <http://en.wikipedia.org/wiki/Pacemaker/>, accessed April 7, 2011.

2.2.2 Basic Functions of Pacemakers

Pacemakers can help a person who has an abnormal heart rate restore a more active lifestyle. It generates and delivers electrical stimuli to the muscles of the heart, in such a way as to cause those muscles to contract and the heart to beat (Petrutiu et al., 2007). During an arrhythmia, a heart can beat too slow (bradycardia), too fast (tachycardia), or with an irregular rhythm and may not be able to pump enough blood to the body. Primarily, in order to restore an effective heart's rhythm to meet the oxygen needs of the body, a pacemaker delivers a controlled, rhythmic electric impulse to the heart muscle. Besides, it is required to determine more exactly when stimuli must be delivered for saving energy.

A modern pacing system consists of at least three main parts, a pacemaker, pacing leads carrying pacing impulses, and a programmer (Shi et al., 2010). Devices such as pacemakers and cardioverter-defibrillators are often programmed through an external device known as a programmer that controls therapies via configurable values. With the programmer, doctors can program the pacemaker's computer with an external device. They do not have to have direct contact with the pacemaker. The programming for pacemakers normally includes demand pacing and rate-responsive one. The former monitors the heart rate and only sends electrical pulses to the heart if it is beating too slowly or if it misses a beat. However, a rate-responsive pacemaker speeds up or slows down the heart rate depending on how active the patient is. It monitors the sinoatrial node rate, breathing, blood temperature, and other factors to determine the activity level.

2.2.3 History of Development

Cardiac pacemakers are one of the most important medical innovations of the 20th century. They were initially conceived in 1949, but only became a permanent fixture in clinical practice in the 1960s and have remained the only effective therapy for symptomatic bradycardia and chronotropic incompetence since then (Das et al., 2009).

In the early 20th century, many experiments, such as drug therapy and electrical cardiac pacing, aimed at investigating the effects of electricity on a human heart, were conducted for recovery from cardiac arrest. Initial methods employed in electrically stimulating the heart were implemented by applying a current that would cause contraction of the muscle tissue of the heart (Haddad et al., 2006). Some successful experiments achieved in that contraction were produced in all the muscles stimulated, including a heart.

In 1902, Einthoven (Woollons, 1995) applied the string galvanometer to the measurement of the electrical potentials developed by the beating heart and demonstrated that these could be detected from electrodes placed on the surface of the body. This opened the possibility of quantifying and displaying the signals typical of a normally-beating heart together with those produced by cardiac arrhythmias and led, eventually, to the development of instruments for recording electrocardiography and to the whole modern science of ECG. In 1932, Hyman designed the first experimental heart pacemaker in New York, which was powered by a hand-wound, spring-driven generator, as the timing mechanism, which provided six-minute of pacing without rewinding. This device allowed him to prolong the lives of two patients for 24-48 hours in 1932, but this work was controversial among his colleagues and the medical institutions. Nevertheless

Hyman can be considered to be the first person who really started cardiac pacing. He also named the procedure when he wrote: “Since this apparatus is a substitute for the non-functioning normal sinus nodal pacemaker, it is called the artificial pacemaker” (Thalen and Meere, 1979).

Research at the beginning of the 1950s aimed at the development of long-term pacing using internal pacemakers. In 1950, two Canadians, Bigelow and Callaghan, presented a paper (Woollons, 1995) describing their work on the stimulation of dog hearts with one electrode in the oesophagus and the other over the precordium, and in the same year they stimulated the sinoatrial node of a patient during open-heart surgery. Zoll’s system used plates held on to the chest wall by a strap and thus avoided the dangers associated with methods involving surgery but could not be used for long-term pacing since it produced many undesirable effects including skin burns, pain and contraction of skeletal muscles in the chest. However, he was able to show that pacing could be used to treat hospitalized patients with complete heart block. In 1958, Furman inserted a catheter carrying a stimulating electrode through a vein into the right ventricle of the heart of a seventy-six year old man. The indifferent electrode was embedded subcutaneously in the chest wall. This was used to successfully pace the patient for 96 days with no ill-effects.

The origin of modern cardiac pacing started when the first battery-powered implantable cardiac pacemaker, developed by Dr. Rune Elmquist (Greatbatch et al., 1991), was used in a patient in 1958 by Dr. Ake Sennings. Elmquist’s first cardiac pacemaker used a rechargeable battery and transistor circuit cast in an epoxy mold about 3/4 of an inch in thickness and about 2 1/2-in in diameter. It required several hours to

recharge every few days by an AC magnetic field. The pacemaker was implanted under the skin with a catheter cable attached to the heart. This pacemaker was the first unit implanted in a patient, which was able to run from batteries and small enough for implantation.

In 1959, W. Greatbatch as an engineer and W. M. Chardack as a cardiologist developed the first fully implantable pacemaker. It was slightly larger but had primary batteries that were supposed to last about seven years. However, they lasted only about 18 months. It also had a catheter electrode hooked directly to the heart. This device was essentially used to treat patients with complete atrioventricular (AV) block caused by Stokes-Adams diseases, delivering a single-chamber ventricular pacing. It measured 6 cm in diameter and 1.5-cm thick, and the total weight of the pacemaker was approximately 180 g.

Dual-chamber pacemakers were introduced in the 1970s. Berkovits announced a bifocal (AV sequential) pacer that sensed only in the ventricle but paced both chambers. In the presence of atrial standstill or a sinus-node syndrome plus AV block, the bifocal pacemaker could deliver a stimulus to the atrium and then, after an appropriate interval, to the ventricle. A dual-chamber pacemaker monitors electrical activity in the atrium and/or ventricle to see if any pacing is needed. If so, the pacing pulses of the atrium and/or ventricle are timed such that they mimic the heart's natural way of pumping. With two-lead systems, not only are twice the number of their parameters to adjust but the relationship between the two chambers may also be adjusted in various ways.

In the early 1980s, a sensor system consisting of a device to measure some relevant parameters from the body, e.g., body motion, respiration rate, pH, and blood

pressure, was incorporated in the pacemaker. The advances in pacemaker in the 1980s have generated a wide variety of complex multi-programmable pacemakers and pacing modes.

The late 1980s and early 90s had seen many further developments not only to make pacemakers smaller, despite their increasing complexity, to last longer and to help one deal with the problems arising out of their increasing complexity. Pacemakers have required more processing power and memory to carry out an increasing number of functions, more circuitry, often several integrated circuits, assembled into very large-scale applications, and interconnections between those circuits have been advanced. The atrio-ventricular delay naturally shortens with exercise and thus pacemakers need to mimic this phenomenon. Pacemakers must not allow the ventricles to track abnormally fast atrial rates and indeed many can now detect changes in atrial rhythm and change modes appropriately. As pacemakers are added with more and more functions, the design using sequential logic circuits becomes time-consuming and more devices are becoming microprocessor-based.

Innovations in 1990s have incorporated microprocessors into pacemakers and/or programmers, virtually transforming systems into implantable computers. While microprocessors offer the possibility of faster revision of pacemaker functions, they can consume more power than an equivalent circuit composed of random logic elements.

The exciting development in the late 90s leads to the trend to develop pacing systems with specialized sensors that enable one to monitor physiological processes. A hemodynamic sensor can note deviations from the norm, and select and apply proper therapies. They can be interrogated not only for their present settings but also for

important real-time data including lead and battery impedance. These devices are able to store significant periods of intracardiac data. Pacemakers could store data related to body functions, which could help physicians manage other health problems, and they could store cardiac intervals and snapshots of waveform data whenever dysfunction is triggered by a condition preset by the clinician.

The most recent advances lie in the ability of some pacemakers to measure their own pacing capture thresholds automatically and to adjust their outputs accordingly, thereby reducing current drain and increasing their longevity. As pacing functions have become increasingly complex, it has become standard practice to build circuitry in a more general, computer-based architecture, with functions specified in software. A software-based pacemaker consists of a telemetry system, decoder, timing circuit, analog sensing, and output circuitry, and analog rate-limiting circuitry, with a microprocessor acting as its controller. Trouble shooting is considerably helped by their ability to generate event markers and intracardiac electrograms as well as acquiring and storing data about the patient's heart rates, rhythms and pacing modes between clinic appointments.

2.2.4 New Features in Modern Pacemakers

Modern pacemakers have many technological advances of functions, including various modes of dual-chamber pacing, rate-responsive algorithms with dual sensors for optimal physiological response, cardiac resynchronization therapy, arrhythmia-prevention algorithms, antitachycardia pacing, hemodynamic monitoring, rest rate and sleep rate limits, and remote monitoring (Das et al., 2009).

The benefits of modern pacemakers include increased patient safety and battery longevity, improved quality of life, cost effectiveness, and remote device interrogation

including data monitoring as well as patient alert functions for device malfunction. They automatically self-adjust the energy output required to pace the heart per the needs of each individual patient. Through actively monitoring the heart on a beat-by-beat basis, they provide pacing only when needed to allow a patient's own heart rhythm to prevail whenever possible, which is beneficial to a patient's cardiac health. Furthermore, the automaticity features of pacemakers enable continuous or intermittent monitoring of various pacemaker parameters including battery voltage, pacing impedance, sensing levels, pacing thresholds, and daily activity log. They may also allow physicians to quickly program the device's timing cycles to deliver optimal therapy to patients.

To illustrate the details of the new features in modern pacemakers, several representative ones are introduced next. An Accent RF pacemaker features daily wireless remote monitoring, providing timely notification of actionable events and flexible remote follow-up scheduling through Merlin.net® Patient Care Network (PCN). An Evia pacemaker system integrates wireless remote monitoring with small size. It is able to provide home monitoring for patients with some sensors. With Closed Loop Stimulation (CLS), Evia responds to changes in the autonomic nervous system on a beat-by-beat basis. CLS is one of the most advanced and physiologic rate regulation sensors. For standard motion-based rate-adaptation, Evia is also equipped with an accelerometer located within the pulse generator. This sensor produces an electric signal during physical activity of the patient. An Adapta pacemaker offers the Medtronic-exclusive pacing mode called Managed Ventricular Pacing (MVP), which enables it to be programmed to deliver pacing pulses to the heart's lower right chamber (ventricle) only when necessary. Victory pacemakers offer an important combination of features, including optimized settings to

save time at implant, Ventricular Intrinsic Preference (VIP) technology to minimize ventricular pacing, the FastPath summary screen to speed follow-up exams, and advanced technologies to extend the life of the device in patients. The company provides a suite of algorithms designed to make it easier for physicians to manage patients with atrial fibrillation (AF). AF is the world's most common cardiac arrhythmia that results in a very fast, uncontrolled heart rhythm caused when the upper chambers of the heart (atrial) quiver instead of beating.

Consequently, modern pacemakers offer a range of advanced pacing features as shown above. On the other hand, since serious but infrequently occurring arrhythmias are difficult to detect and diagnose, a biosensor system incorporating physiological information to aid diagnosis is an important issue for modern pacemaker systems.

2.3 Biosensors in Modern Pacemaker Systems

A biosensor is a device for detection of an analyte that combines a biological component with a physicochemical detector component. Biosensor networks might have a base station that handles all the processing, communication, and power delivery, owing to the sensing units' proximity to each other.

Biosensors fall into two main categories, wearable and implantable. The former, although not as invasive as the implantable counterparts, nevertheless must withstand the human body's normal movements and infringe on them as little as possible. Implantable sensors measure parameters inside the body and mostly operate as interfaces to relatively small software components attached to or implanted into human bodies. Bidirectional

communication provides interfaces between a person and a remote information system that provides healthcare services, diagnosis, or upgrades.

Normally, biosensors consist of three parts:

1. The sensitive biological element (biological material, a biologically derived material or biomimic);
2. The transducer or detector element that works in a physicochemical way to transform a signal resulting from interaction of the analyte with the biological element into another signal (i.e., transducers) that can be more easily measured and quantified;
3. The associated electronics or signal processors that are primarily responsible for the display of the results in a user-friendly way. This sometimes accounts for the most expensive part of a sensor device.

Biosensors have been incorporated in most pacemakers as a programmable option. As the sensing technology advances, pacemakers have been able to detect various kinds of physiological variables as well as cardiac signals to be utilized for diagnosis, such as body activity, QT interval, minute ventilation, intraventricular ECG, respiratory rate, intraventricular pressure, oxygen saturation, and impedance. Biosensors fall into those that detect body activity and so react to movement (accelerometers) and those that measure some consequence of a physiological change during exercise or other conditions (QT interval). Table 2.1 (Shi & Zhou, 2011) illustrates the categories of sensors for pacemaker systems.

In addition, the role of sensors has been expanded to include functions other than rate augmentation such as the detection of atrial and ventricular capture, and monitoring of heart failure, sleep apnoea, and haemodynamic status. Through the utilization of sensors to monitor cardiac haemodynamics, right ventricular pressure has been found to be a good estimate of pulmonary arterial diastolic and capillary wedge pressure. Hence, a fully implanted device has been used to reduce heart failure hospitalization.

Table 2.1 Categories of Sensors for Pacemaker Systems

Physiological Parameter	Speed of Response	Sensor Reliability	Representative Sensors
Body vibration or movement	fast	high	Accelerometer; piezoelectric crystal
Respiratory rate	moderate	high	minute ventilation; blended sensor
Heart rate	fast	high	PEA; blended sensor
Physiological impedance	slow	moderate	CLS; minute ventilation
Temperature	slow	moderate	right ventricular blood temperature
Venous oxygen saturation	moderate	moderate	mixed venous oxygen saturation
Blood pressure	slow	moderate	rate of change of right ventricular blood pressure (dP/dt)
Electrocardiograph	moderate	moderate	QT interval

2.3.1 Activity Sensors

Chronotropic incompetence is defined as the inability of a sinus node to react adequately with an increase in heart rate to exercise or other movement. For patients suffering from this disease, rate-response pacemakers were invented. It represents a significant advance over constant rate demand ventricular pacing when first introduced in the 1980s (Rossi et

al., 1984), which relies on sensors to detect patient's activity. Activity sensors allow for instance to tailor the rate response to the individual patient with proper treadmill protocols (Greco et al., 2000). Fast reaction to terminate short exercise represents further advantage of activity sensors. The key element of such pacemakers is their activity sensors that offer rapid response to exercise by assessing body vibrations or movements. They are old and widely used. Activity-controlled pacing with vibration detection remains the most widely used form of rate adaptation because it is simple, easy to apply clinically, and rapid in onset of rate response.

The working modality is based on the relationship between activity and heart rate. Activity may be recognized by an accelerometer that identifies the postural changes and the body movements related to physical activity. Because it is non-invasive (the sensing device is placed inside the pacemaker without direct contact with the human body), this is the preferred technique used in most rate-responsive pacemakers sometimes complimented with sensors for other parameters such as ventilation rate, venous O_2 saturation, or body impedance (Arnaud et al., 2006). Such sensors have been almost universally applied because of their technical simplicity and relative lack of incorrect responses.

An accelerometer evaluates amplitude representing a movement force and also a signal frequency, which is a rate scale factor of movement. It is placed in a pacemaker to detect a patient's movement and physical activity and generate an electronic signal that is proportional to physical activity. An accelerometer responds to a particular range of vibration frequencies, reducing unwanted external vibrations. Therefore, its use is a simple but robust solution for activity sensing to register body movement.

Basically, an accelerometer is mounted on the hybrid circuitry of the pacemaker and is independent of the mechanical forces of the surrounding tissue but dependent on patient motion. The schematic drawing of how an activity sensor uses an accelerometer positioned within the pulse generator is shown in Figure 2.3. Accelerometer sensors result in a very fast almost immediate response, require no special lead, and at present are the most widely used type of sensors for adaptive-rate pacing. They are used most often due to their low cost and ease of programming (Edgar et al., 1996).

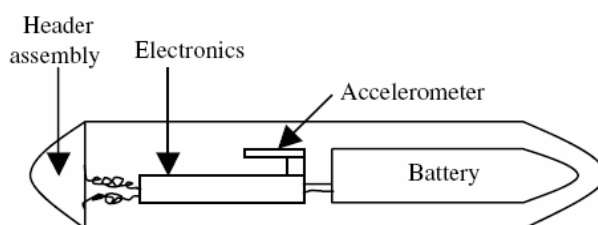

Figure 2.3 Accelerometer sensing system (Hayes et al., 2008).

However, accelerometers have some disadvantages, e.g., lack of acceleration in the case of increased metabolism without vibration of the body. One of the main limitations is the lack of proportionality with physical activity. In addition, stimuli other than dynamic exercise such as isometric exercise, mental activity, and emotional stress are unable to stimulate it. Besides, after longer exercise, an oxygen debt may require a sustained rate to increase, which is not provided by activity sensors during recovery because they are unable to acknowledge the oxygen debt. Moreover, their lack of response to the activity not related to body movements, e.g., isometric exercise, mental stress, or metabolic inadequacy consequent to pathologic conditions, and possible

mismatch between exercise intensity and rate increase, represent their limitations (Dell'Orto et al., 2004). Essentially, joining two different types of sensors in a single pacemaker to fully use their advantages and eliminate their deficiencies can solve this problem.

2.3.2 QT Interval

The QT interval reflects the total duration of ventricular myocardial repolarization. It measures the interval between the pacing spike and the evoked T-wave as the sensor and this interval shortens with exercise. The QT interval may not be chronically stable due to a variety of cardiac drugs and may be affected by acute myocardial ischaemia. Despite improvements in the algorithm employed to determine the pacing rate, the speed of onset remains relatively slow. The interval may vary chronically with time necessitating frequent medical intervention to maintain optimal rate response (Baig et al., 1988), (Rickards et al., 1981).

Since the faster the heart rate, the shorter the QT interval, it may be adjusted to improve the detection of patients at the increased risk of ventricular arrhythmia. Modern computer based ECG can be used to calculate a corrected QT easily, but this correction may not aid in the detection of patients at the increased risk of arrhythmia. The standard clinical correction is to use Bazett's formula (Bazett, 1920), by calculating the heart rate-corrected QT interval.

$$Q_{cor} = \frac{Q}{\sqrt{I}} \quad (2.1)$$

where Q_{cor} is the QT interval corrected for heart rate, and I is the interval from the onset of one QRS complex to the onset of the next QRS complex, measured in seconds, often derived from the heart rate as 60 bpm. The QRS complex is a name for the combination of three of the graphical deflections seen on a typical ECG.

$$Q_F = \frac{Q}{I^{1/3}} \quad (2.2)$$

Sensors using QT interval variations are based on the finding that physical activity and circulating catecholamine shorten the QT interval, since a prolonged QT interval is a risk factor for ventricular tachyarrhythmias and sudden death. This interval is an important ECG diagnostic parameter for cardiologists. This type of sensors detects the increase of heart rate during recovery after exercise. Prolonged QT interval on the ECG is associated with an increased threat for arrhythmia and sudden death. Nevertheless, since the QT interval is affected by drugs, electrolyte disturbances and increased circulating catecholamine, these sensors cannot be used in patients with acute myocardial infarction, following which congestive heart failure may occur as complication.

2.3.3 Dual Sensors

Nowadays, various types of sensors have been used to control pacemakers. The proliferation of alternate sensors is a clear indication that no currently available single sensor approaches the characteristics of an ideal sensor, which should be physiologic, quick to respond, and able to work well with minimum energy demands or current drain. The ideal sensor would be able to increase the rate proportionally to the patient's need

and metabolic demand, work compatibly with the rest of the pacemaker, reproduce sinus node behavior in all the different activities of daily life, and be easy to program and adjust. It would not require any additional lead system to work.

In the absence of an ideal sensor, the combination of dual sensors has been investigated. Crosscheck between sensors is used to avoid inappropriate rate increase. During the crosscheck both sensors can control each other and the pacing rate is changed only if both or a predominant sensor agrees (Connelly, 1993), (Cooper, 1994). The most common option in rate response devices is to obtain circadian heart rate variation with two different hourly mean rates during day and night. Physiologic sensors and activity ones can provide rate variations based on single sensor solicitation. For example, after the administration of a drug that shortens the QT interval, a QT interval sensor would indicate the need for rate increase, but the pacing rate would not change because the activity sensor is not activated. Conversely, passively tapping on the device would activate the activity sensor and indicate a rate increase, but the pacing rate would not be modified because the QT-interval sensor would not be activated by this maneuver. Two lower heart rates are programmed for day and night. When the sensor is constantly solicited, the daytime lower rate is used. On the contrary, when the sensor's signal level is low for a consistent period of time, the device switches to nighttime lower rate.

This type of devices should theoretically ensure more physiological steering of the frequency of heart rhythm than the traditional rate-response pacemakers with accelerometer sensors only. The disadvantages of this solution are higher power consumption, reduced lifespan, and higher price. Additionally, patients who have these types of pacemakers implanted need follow-up visits more often.

2.3.4 Minute Ventilation

Minute ventilation, the product of respiratory rate (the number of breaths per minute a person is taking) and tidal volume, is one such sensor that has an excellent correlation with metabolic demand, including body oxygen consumption and cardiac output (Khunnawat et al., 2005). Tidal volume is the lung volume representing the normal volume of air displaced between normal inspiration and expiration when extra effort is not applied. It satisfies the following equation:

$$\dot{V} = R \times T \quad (2.3)$$

where \dot{V} , R , and T represent minute ventilation, respiratory rate and tidal volume. Its typical values are around 500ml or 7ml/kg bodyweight (Beardsell et al., 2009).

Minute ventilation measures variations in transthoracic impedance signal, the volume of air inhaled or exhaled from a person's lungs in one minute, by delivering frequent low-amplitude electrical pulses from the pacemaker. These impedance measurements are used to calculate minute ventilation that is then translated into an indicated pacing rate (Khunnawat et al., 2005).

However, this kind of sensors cannot provide higher reliability in patients with obstructive pulmonary disease, interference with cardiac monitors and posture (Duru et al., 2000) or false positive reaction in hyperventilation. The specifications, sensed signals, advantages, limitations and application conditions for accelerometer, minute ventilation, QT interval, and dual sensors are concluded, as shown in Table 2.2 (Shi & Zhou, 2011).

2.3.5 Other Biosensors

Blood pressure is a clinically important measurement of change rate of right ventricular blood pressure (dP/dt), as an indicator of the force of contraction. Because dP/dt is affected by the dynamics of contraction, intrinsic and paced beats result in different level signals.

Table 2.2 Features of Main Biosensors

Sensor	Measured Data	Advantage	Limitation and Application
Activity Sensor (Accelerometer)	Body movement or vibrations	Rapid response to exercise	Less physiologically accurate
Minute Ventilation	Volume of air inhaled/exhaled in one minute	Physiological correlation with metabolic demand	Slow to respond to the onset of exercise
QT Interval	Interval between pacing spike and evoked T-wave	Important ECG diagnostic parameter	Unstable chronically
Dual Sensors	Dependent on two self-sensing devices	Control each other	High power consumption

As increases in venous return further distend the ventricle, the myocardial fibers contract with greater force (Frank-Starling law). During the exercise the right ventricular pressure waveform increases in amplitude with a decrease in duration. Thus, the first derivative of pressure with respect to time (dP/dt) increases, having a strong correlation with the sinus rate. Apart from technical problems, the main concerns with the sensor system are the influence on the pacing rate of non-exercise stimuli such as posture changes and the longevity of the sensor which may be affected by fibrin coating.

Another one is the temperature sensor for sensing right ventricular blood. The sensor required for temperature measurements is an electrical resistor making use of a semiconductor whose resistance varies with temperature. Right ventricular blood temperature is a byproduct of activity from all parts of the body and reflects a composite of autonomic, biochemical, metabolic, circulatory, respiratory, and cardiac influences. A temperature sensor is affected by physical activity and emotional stress, and increases with workload because about 80 percent of the energy expended in skeletal muscles is converted to heat. At the onset of exertion the blood temperature in the right ventricle falls as cold peripheral blood reaches the central circulations. Increased flow in peripheral blood vessels during exercise and emotional stress may cause a transient decrease in the central blood temperature, because an increased portion of the total cardiac output perfuses cooler peripheral tissues and enters the central circulation at hypothermic levels. Clinical studies (Sarabia et al., 2008) show that temperature-based pacemakers restore rate response during a large number of activities typically associated with heart rate increases. However, temperature changes are higher than in those more physically fit in elderly patients, probably due to reduced heat dissipation related to more pronounced reduction of blood flow to the skin during exercise. In addition, temperature changes are not confined to physical activity, since blood temperature can be also affected by several other parameters such as emotion, external temperature variations, hot baths and infections.

In addition, for avoiding many problems of interference both with blood and with external electromagnetic fields, fiber-optic technology has been proposed for several technical purposes and, in medicine, for purposes such as respiratory monitoring. Their

primary principle of operation relies on the modulation of light. The fiber is inserted into a pacemaker lead or an elastic catheter, positioned inside a heart chamber. Only the end of the fiber outside the heart can be used for coupling the light into and out of the fiber. Therefore, the end within the heart is provided with a mirror to reflect the light (Hoeland et al., 2002). Thus, fiber-optic force sensors have been extensively used for numerous medical applications, especially for recording the movements of the myocardial wall within the heart.

2.3.6 Future Development

As mentioned above, the resulting combined sensors require a complicated lead system to work and consume high energy in a pacemaker. Instead of a multi-sensor method, this study proposes a novel algorithm based on the intracardiac ECG waveform and YNI (Yanagihara, Noma, and Irisawa) model to analyze the pole-zero characteristics of the phase error between abnormal ECG and entrained YNI-response. This intelligent diagnostic sensing system for a pacemaker would be also an innovative tendency in the development of biosensors. It can replace the complex sensor system, and set up to an individual patient and is then checked and adjusted periodically.

At present, many of pacemakers relay stored information to a server, which then makes the distilled data available to clinicians, in some cases via web browsers. They communicate with PCs to upload stored information and may soon communicate with devices such as smartphones. All these conveniences may come with possibility that hackers could break into the pacemakers' communications and either send harmful commands to the devices or steal private patient information and even reprogram their

devices. Hence, researchers and manufacturers are required to design a sensor with security features that protect a patient's data.

2.4 Fuzzy PID Controller for Cardiac Pacemaker Systems

The approach of fuzzy logic control has been widely used in many successful industrial applications, which demonstrates its high robustness and effectiveness properties. It is one of the classic methods in intelligent control. Well-designed fuzzy logic controllers have the characters of good dynamic performance and strong robustness. Besides, fuzzy set theory plays an important role in dealing with uncertainty when making decisions in motion control industry. Presently, various fuzzy logic controller structures are proposed and extensively studied.

Although fuzzy control with strong robustness is used to realize the fast response and stability of the system, the steady state error is in existence. In addition, many physical systems, such as the cardiac pacemaker systems, are either highly nonlinear or too complex to control with traditional strategies. Thus, if an expert can qualitatively describe a control strategy, one can use the controller to directly translate from the linguistic rules developed by the expert to a rule base for a fuzzy controller (Tao, 2002). The mathematical complexity in the conventional fuzzy control makes the formulation of a tuning mechanism an extremely complex problem. To reduce the complexity of the adaptive tuning system, the linear combination of input variables with a scaling factor of a PID controller adopted in the fuzzy control has been widely applied.

The proportional-integral-derivative (PID) controller is one of the most popular control methods utilized in industry, because of its simplicity, clear functionality,

versatility, robustness, and ease of implementation even for some classes of nonlinear systems (Ang et al., 2005), (Kim et al., 2005), (Silva et al., 2002), (Skoczowski et al., 2005). Furthermore, a classical PID controller has the ability to remove the error. It has been reported in (Ang et al., 2005) and (Skoczowski et al., 2005) that more than 96% of control loops employ conventional PID controllers. The process for designing PID controllers for industrial automation is quite elaborated and can be difficult in practice, if multiple and conflicting objectives are to be achieved (Ang et al., 2005). This stimulates the development of some advanced tuning methods that can be incorporated in hardware modules, and the search is on to find the next key technology. However, the deviations of the system parameters from the known values cause the performance of the closed loop system to deteriorate, resulting in larger overshoot, longer rise and settling times, and, possibly, even an unstable system. Thus, there is a need for the combination of other types of controllers, which can account for nonlinearity or somewhat adaptable to varying conditions in real time. Other controllers being employed include a fuzzy-PID (FPID) controller in order to achieve a desired performance level.

Consequently, such a combined FPID system, which retains both of the characteristics of the conventional PID controller and fuzzy logic controller, may be helpful for the cardiac pacemaker systems. In order to improve further the performance of the transient and steady state responses of this kind of fuzzy controllers, various strategies and methods are proposed to tune the PID-type fuzzy controller parameters (Bouallegue et al., 2011).

An FPID controller has recently found extensive applications for industrial and medical control and has attracted the growing attention and interest of many control

researchers due to its model-free characteristic. This type of controllers, as currently demonstrated by a number of experiments, show encouraging results (Hu et al., 2001), (Li et al., 2006), (Tao et al., 2000). Few choices exist for implementation when one attempts to use FPID controllers in existing systems and devices. Nonetheless, the main problem with fuzzy logic control is that there is no systematic approach for the construction of a fuzzy controller such as scaling factors, linguistic rules, and shape of the fuzzy sets (Ofoli et al., 2006).

Because error exists in a quantization process, a control action is less delicate, and steady-state error is present. In the steady state, a PID controller has high control precision. Therefore, the advantages of an FPID controller are fully taken. That is to say, when the deviation between the given value and the measured one is greater than or equal to the limit, a fuzzy control algorithm is used to improve the response speed of the system; when it is less than the limit, a PID control algorithm is adopted to eliminate the steady state error of the system. The selection of a reference value is very important. Generally, it can be adjusted based on the actual conditions.

After 1990, some researchers began to analyze and research the fuzzy PID controller's mathematical expression and had obtained valuable research results. The structure of an FPID controller includes one-dimension, two-dimension, and three-dimension controllers. More than three-dimension controllers are not widely used because of their complexity (Qiu et al., 2011). Two-dimension controllers are widely used because of their good adaptability and relatively simple structure.

Fuzzy controllers have two main parts that need to be designed. One is the control structure composing of fuzzy rules, identifying the fuzzy inputs and outputs and their

linguistic description. The other is a fuzzy reasoning method. One of the most widely used design methods for fuzzy controllers is to define membership functions of linguistic variables and to formulate fuzzy rules by control engineers. In fuzzy control, linguistic descriptions of human expertise in controlling a process are represented as fuzzy rules or relations. This knowledge base is used by an inference mechanism, in conjunction with some knowledge of the states of the process in order to determine control actions (Zhao et al., 1993).

For the conventional fuzzy controllers having two inputs and one output, the fuzzy sets of the error e and the change in error Δe are denoted as A_{i1} and A_{j2} . A fuzzy controller can usually be described by a set of if-then rules (Zhao et al., 1993)

$$\text{if } e = A_{i1} \text{ and } \Delta e = A_{j2} \text{ then } u = u_{ij} \quad (2.4)$$

where u and u_{ij} are output control signal and crisp values, respectively. With product-sum inference, the degree of membership for the antecedent part in the rule is

$$d_{ij} = D_{i1}(e) D_{j2}(\Delta e) \quad (2.5)$$

where $D_{i1}(e)$ and $D_{j2}(\Delta e)$ are the degree of memberships in A_{i1} and A_{j2} .

Due to the PID controller's simplicity and flexibility, the overall performance with respect to adaptive tuning operations is improved based on conventional fuzzy control. In addition, a PID controller adds predictive capability to the controller and improves the transient response so as to reduce error amplitude. It consists of three terms

reflecting proportional amplification of the error signal, its integration and derivation. PID controller applies a signal to the process that is proportional to the actuating signal in addition to adding integral and derivative of the actuating signal. The control signal in a conventional PID controller $u(t)$, for a joint variable, $x(t)$, is computed by combining proportional, integral, and derivative terms (Juang et al., 2008)

$$x(t) = K_p e(t) + K_I \int e(t) dt + K_D \frac{du(t)}{dt} \quad (2.6)$$

$$e(t) = r(t) - u(t) \quad (2.7)$$

where K_p , K_I , and K_D are the proportional, integral, and derivative gains, respectively.

The cumulative production of these three components has a main effect for reduction of the steady state error due to the integration factor and the improvement of the response speed due to the proportional factor while reducing response overshoot due to the derivative factor (Juang et al., 2008). Therefore, by taking advantage of both the system of if-then rules in the fuzzy knowledge based system (Hatzimichailidis & Papadopoulos, 2008), (Li & Gatland, 1996), and well-defined PID controller. This study proposes a novel control design for the dual-sensor pacing system. An FPID controller is placed within the feedback control loop, and computes the PID actions through fuzzy inference.

CHAPTER 3

DIAGNOSIS OF CARDIAC ABNORMALITIES

3.1 Mathematical Model of Human Heart

Presently, since there are no universally-accepted mathematical models to illustrate the activities of a heart, as a proven SA model, the YNI model is adopted to represent them. The first model of heart activities of a single isolated rabbit SA nodal cell was developed from the multi-cellular Noble and Noble peripheral model (Demir et al., 1994), (Noble et al., 1984), (Noble et al., 1989). Shortly thereafter, Wilders et al. (Wilders et al., 1991) published a model of single SA nodal cell activities based on single cell experimental data on cell dimensions and membrane capacitance. Subsequently, two single SA nodal cell models were formulated (Dokos et al., 1996), (Grant et al., 1982), (Michaels et al., 1987).

The most widely used model of action potential behavior for SA nodal cells is due to Yanagihara, Noma, and Irisawa (YNI) (Yanagihara et al., 1980). By contrasting other SA nodal cell models, the YNI model is an established and accurate sinoatrial model of the generation and propagation of the action potentials in the heart. For quantitative investigations, numerical simulations of the activity of cardiac sinoatrial cells are performed by using an YNI model that is a more physiologically relevant model than others. As with all cardiac cell models, the YNI model is of Hodgkin-Huxley type which is based on the reported voltage clamp data (Cloherty et al., 2006), (Luo et al., 1991). The model simulates the spontaneous action potential and illustrates the current-voltage relationship.

The YNI model is an established cardiac sinoatrial node model that includes four time-dependent currents and a time-independent one. The former are the sodium current I_{Na} , which is a fast inward current, and potassium current I_K , both of which are similar to the Hodgkin-Huxley currents, slow inward current I_s , and delayed inward current activated by hyperpolarization I_h . The time-independent one is leakage current I_l .

The conservation of transmembrane currents, in units of ($\mu\text{A}/\text{cm}^2$), takes the following form as shown in Figure 3.1:

$$C_m \frac{dV}{dt} + I_{Na} + I_K + I_l + I_s + I_h = I_{app} \quad (3.1)$$

where C_m ($\mu\text{F}/\text{cm}^2$) as a constant denotes the capacitance of the cell membrane, V (mV) as the output or response of the YNI model denotes the membrane potential, and I_{app} is the applied external current.

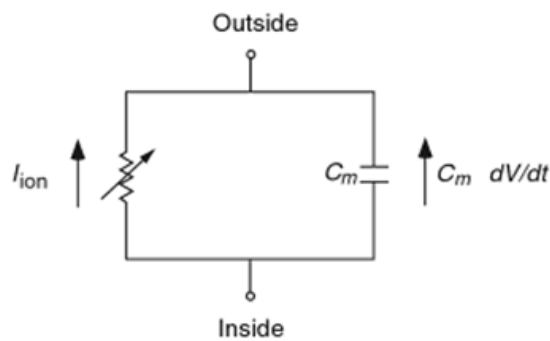

Figure 3.1 Electrical circuit model of the cell membrane (Keener & Sneyd, 1998).

The action potential is shaped similarly to the Hodgkin-Huxley action potential but is periodic in time and slower. I_{Na} , I_K , I_l , I_s , and I_h denote the sodium current, potassium current, leakage current, slow inward current and hyperpolarization-activated current, respectively. The most significant current in the YNI model is the slow inward current I_s . Not only does this current provide for most of the upstroke, it is also responsible for the oscillation. After repolarization by the potassium current, the slow inward current gradually depolarizes the node until a given threshold is reached and an action potential is initiated in the oscillation. Hence, the response of the YNI model that depends on these currents in the human body provides a regular heartbeat. Although there are other ionic currents, primarily the chloride current, in the Hodgkin-Huxley theory they are small and lumped together into one current called the leakage current. These ion currents are described by the following equations (Keener & Sneyd, 1998):

$$I_{Na} = 0.5m^3h(V - 30) \quad (3.2)$$

$$I_K = 0.7p \frac{\exp(0.0277(V + 90)) - 1}{\exp(0.0277(V + 40))} \quad (3.3)$$

$$I_l = 0.8(1 - \exp(-\frac{V + 60}{20})) \quad (3.4)$$

$$I_s = 12.5(0.95d + 0.05)(0.95f + 0.05)(\exp(\frac{V - 10}{15}) - 1) \quad (3.5)$$

$$I_h = 0.4q(V + 45) \quad (3.6)$$

Note that $\exp(x)$ means e^x in this thesis. Six gating variables $m, h, p, d, f,$ and q satisfy the first-order differential equations of the following form

$$\frac{dw}{dt} = \alpha_w(1-w) - \beta_w \cdot w \quad (3.7)$$

where $w \in \{m, h, p, d, f, q\}$.

Some of constants α_w and β_w can be written in the following form with constant values, where V_b is the potential gain across the battery.

$$\frac{C_1 \cdot \exp\left(\frac{V - V_b}{C_2}\right) + C_3 \cdot (V - V_b)}{1 + C_4 \cdot \exp\left(\frac{V - V_b}{C_5}\right)} \quad (3.8)$$

Those that do not fit the above form are

$$\alpha_p = \frac{9 \times 10^{-3}}{1 + \exp\left(-\frac{V + 3.8}{9.71}\right)} + 6 \times 10^{-4} \quad (3.9)$$

$$\alpha_q = \frac{3.4 \times 10^{-4} \times (V + 100)}{\exp\left(\frac{V + 100}{4.4}\right) - 1} + 4.95 \times 10^{-5} \quad (3.10)$$

$$\beta_q = \frac{5 \times 10^{-4} \times (V + 40)}{1 - \exp\left(-\frac{V + 40}{6}\right)} + 8.45 \times 10^{-5} \quad (3.11)$$

$$\alpha_d = \frac{1.045 \times 10^{-2} \times (V + 35)}{1 - \exp\left(-\frac{V + 35}{2.5}\right)} + \frac{3.125 \times 10^{-2} \times V}{1 - \exp\left(-\frac{V}{4.8}\right)} \quad (3.12)$$

$$\beta_f = \frac{9.44 \times 10^{-4} \times (V + 60)}{1 + \exp\left(-\frac{V + 29.5}{4.16}\right)} \quad (3.13)$$

Thus, the YNI mathematical model (3.1) can be simplified as

$$C_m \frac{dV}{dt} + I_{ion} = C_m \frac{dV}{dt} + \frac{V}{R_m} = I_{app} \quad (3.14)$$

where C_m and R_m are representations of the effective local myocardial membrane capacitance and resistance.

3.2 Diagnosis of Cardiac Abnormalities

3.2.1 Introduction

At present, many problems exist regarding pacemakers in the treatment under certain conditions. One of them is the diagnosis of cardiac abnormalities. This is because it is difficult to detect and analyze serious and infrequently occurring arrhythmias. Furthermore, it is not easy to distinguish exactly between deadly abnormalities and temporary arrhythmias by using merely ECG signals.

To solve these problems especially in diagnosis, various types of sensors, such as activity sensor, QT interval, minute ventilation, and dual sensors, have been used to detect body activity and measure some consequence of a physiological change during rest, exercise, and facing environmental or emotional changes. The proliferation of alternate sensors is a clear indication that currently there is no available sensor approaches the characteristics of an ideal sensor. The ideal sensor would respond proportionally to biological oxygen demand or alternately to the sinus rate response of the healthy heart, over short and long time periods. Because no single sensor can fulfill all the requirements of an ideal sensor, the trend is now to combine various sensors. The resulting combined sensing system requires a complicated lead system to work and consume high energy.

When deadly abnormalities occur, a pacemaker must be fired to help the heartbeat restore to the normal. However, if the arrhythmia can be self-adjusted by the human body to return to a regular status, it is a temporary abnormal heart rhythm due to a sudden change in the body or surrounding environment, which does not require firing the pacemaker. Thus, to replace multiple sensors and save energy from reducing unnecessary

stimulations, this study develops a diagnostic system that ably utilizes the ECG signals based on a sinoatrial pacemaker model, i.e., the YNI model to detect deadly cardiac abnormalities and analyze the threshold condition to fire a pacemaker necessarily.

In order to develop a diagnostic pacemaker system to differentiate deadly abnormalities and temporary arrhythmias, this study identifies the characteristics of cardiac abnormalities by utilizing the YNI model. It performs the entrainment of frequency between ECG signals and the YNI model's response, called YNI-response for short, since two interacting oscillating systems have different periods when they function independently. After the frequency entrainment, there is the phase error existing between ECG signals and the entrained YNI-response before falling into synchrony. The error is approximated by a second-order system, in which pole-zero analysis of the transfer function is performed in the simulation to identify the characteristics of deadly cardiac abnormalities (bradycardia and tachycardia).

3.2.2 Frequency Entrainment

Entrainment between two rhythms is a very well-known phenomenon in the theory of nonlinear dynamics (Hayashi et al., 1960). It is a process whereby two interacting oscillating systems, which have different periods when they function independently, assume the same period. Frequency entrainment usually occurs when the coupling between two interacting oscillators is sufficiently strong (Seidel et al., 1998) and a periodic force is applied to a system whose free oscillation is of the self-excited type. The frequency of the self-excited oscillation falls in synchronism with the driving frequency, provided these two frequencies are not far different. The two oscillators may fall into

synchrony. If their difference is large enough, one may expect the occurrence of a beat oscillation.

As stated above, the role of the SA node acts as a natural pacemaker function, including frequency entrainment of the SA node, and propagation of excitation into the atrial tissue. To develop a diagnostic pacemaker system, the ECG signals provide the actual heart rate while the YNI model serves as the pacemaker model in the simulation and analysis. Thus, the entrainment of frequency between ECG signals and YNI-response denotes the entrainment between the ECG signals measured inside a pacemaker system and regular signals generated by the pacemaker. For the two interacting oscillating systems, ECG signals and YNI-response have different periods when they function independently.

Following the entrainment of frequency, the phase error between ECG signals and entrained YNI-response can be identified and approximated by a second-order system. In the subsequent simulation and analysis, normal and abnormal ECG signals are applied to entrain the YNI model. The pole-zero analysis of the resulting transfer function is performed in the study to detect the characteristics of deadly cardiac abnormalities.

3.3 Simulation and Analysis

3.3.1 Entrained YNI Model

The normal rhythm of a heart is controlled by the discharges from the SA node. The cases of an adult at rest are utilized to illustrate the method. For an average adult at rest, the normal heart rate ranges from 60 to 100 bpm. Thus, in the simulation of a normal case,

the YNI model is entrained by the heart rate of 80 bpm of ECG signal in Figure 3.2. The YNI-response to the entrainment by the normal heart rhythm is shown in Figure 3.3.

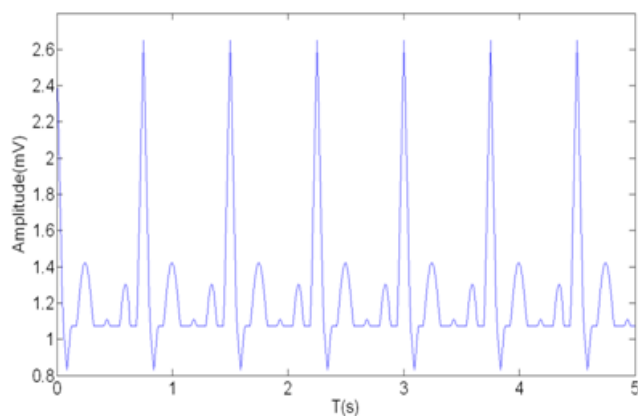

Figure 3.2 The normal ECG.

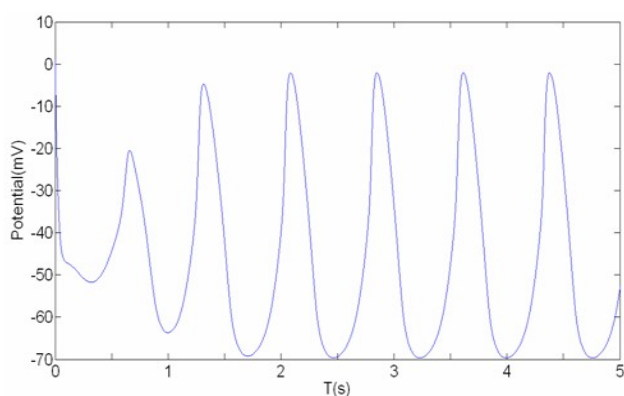

Figure 3.3 The normal-entrained YNI-response.

After the entrainment, two oscillators will fall into synchrony with the driving frequency. These two frequencies are much closer gradually and finally fall into synchrony completely. Nevertheless, the phase error exists until synchrony and it can be approximated by a second-order system, which is derived in this study. In order to achieve a diagnostic pacemaker system, the pole-zero analysis of the transfer function in

the second-order system is conducted in the next section to detect the characteristics of cardiac abnormalities.

Since the ECG signals adopted in the simulation are the assured threshold cases of cardiac abnormalities, the heart rates of 50 bpm and 120 bpm (Josko et al, 2005), (Liu et al., 2011) are obtained as the thresholds of bradycardia and tachycardia, respectively. In Figure 3.4, the heart rate of 50 bpm of ECG signal is adopted to entrain the YNI model for bradycardia in the simulation. The response to the entrainment of the model is shown in Figure 3.5. For the case of tachycardia, the heart rhythm of 120 bpm of ECG signals is adopted to entrain the YNI model in Figure 3.6. The model response to the entrainment by the tachycardia heart rate is plotted in Figure 3.7.

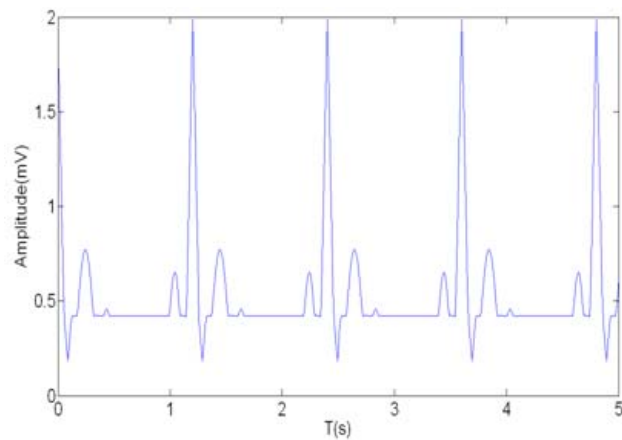

Figure 3.4 The bradycardia ECG.

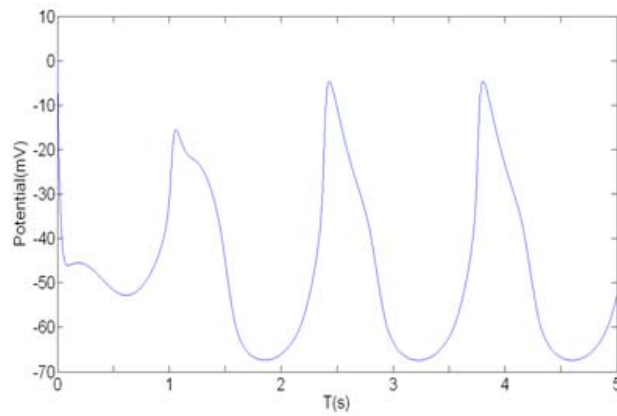

Figure 3.5 The bradycardia-entrained YNI-response.

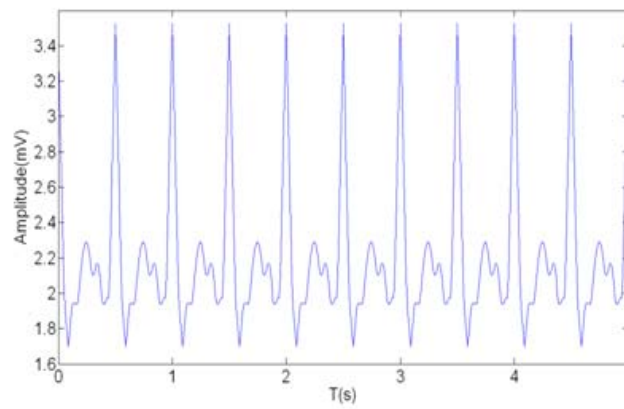

Figure 3.6 The tachycardia ECG.

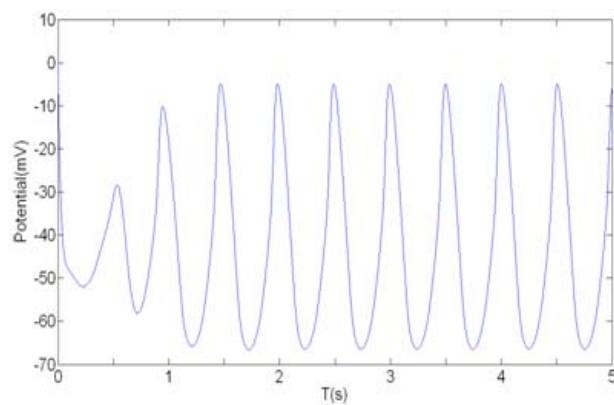

Figure 3.7 The tachycardia-entrained YNI-response.

3.3.2 Pole-zero Analysis of Phase Error

The output signal of a phase detector, which is a multiplier in simple terms, is a function of the phase error between two input signals. By adding a low pass filter at the output of the phase detector, the bandwidth should be quite small to knock out noise and also unwanted signal. The amplitude of the error signal is directly related to the phase error (Gardner, 2005).

As stated previously, the phase error between normal/abnormal ECG signals and the entrained YNI-response before falling into synchrony can be approximated by a second-order system. A series of transfer functions for bradycardia and tachycardia, and transfer functions under normocardia are constructed with the same basic structure but different parameters. In this section, the phase error plots for normal rhythm of 80 bpm, bradycardia of 50 bpm and tachycardia of 120 bpm for the threshold of cardiac abnormalities, are shown in Figures 3.8-3.10, respectively. The corresponding transfer functions of the second-order systems can be written as the following equations.

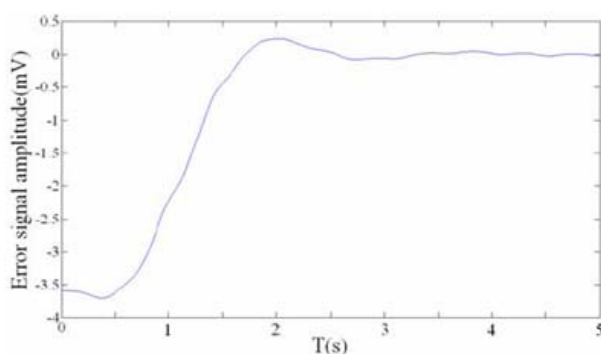

Figure 3.8 The normal phase error.

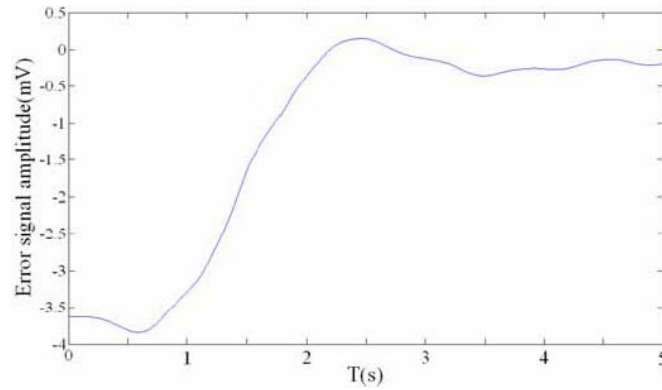

Figure 3.9 The bradycardia phase error.

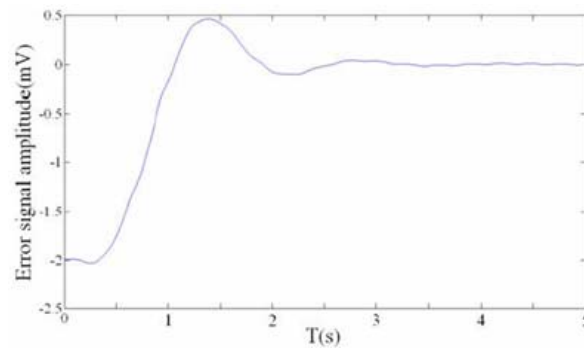

Figure 3.10 The tachycardia phase error.

$$H(s) = \frac{0.8889s - 6.7778}{s^2 + 1.7222s + 1.8889} \quad (3.15)$$

$$H(s) = \frac{1.2632s - 3.2105}{s^2 + 1.2105s + 0.8947} \quad (3.16)$$

$$H(s) = \frac{0.7143s - 5.7571}{s^2 + 1.3429s + 2.4286} \quad (3.17)$$

From all of transfer functions of various heart rates for normal, bradycardia and tachycardia, the tendency of transition between normal and abnormal rhythms is

concluded from the pole-zero analysis of transfer functions in the second-order systems, in order to identify the characteristics of cardiac abnormalities for bradycardia and tachycardia.

For bradycardia with obvious symptoms, the heart rate dropping below 50 bpm:

- a. The mod of poles of the transfer function

$$\text{mod} \leq 0.9459 \quad (3.18)$$

- b. The angle of poles

$$\alpha \leq 50.217^\circ \quad (3.19)$$

- c. The zero

$$s \leq 2.542 \quad (3.20)$$

For tachycardia, the heart rate greater than 120 bpm:

- a. The mod of poles of the transfer function

$$\text{mod} \geq 1.5584 \quad (3.21)$$

b. The angle of poles

$$\alpha \geq 64.48^\circ \quad (3.22)$$

c. The zero

$$s \geq 7.8 \quad (3.23)$$

A list of characteristics of poles and zeros for three above transfer functions is given in Table 3.1, and the corresponding pole-zero plots are shown in Figure 3.11.

Table 3.1 Pole-zero Analysis in Different Cases

Cardiac Case	Zero	Mod-Pole	Angle-Pole
Bradycardia (50 bpm)	$s = 2.542$	0.9459	50.217°
Normocardia (80 bpm)	$s = 7.625$	1.3744	51.2°
Tachycardia (120 bpm)	$s = 7.8$	1.5584	64.48°

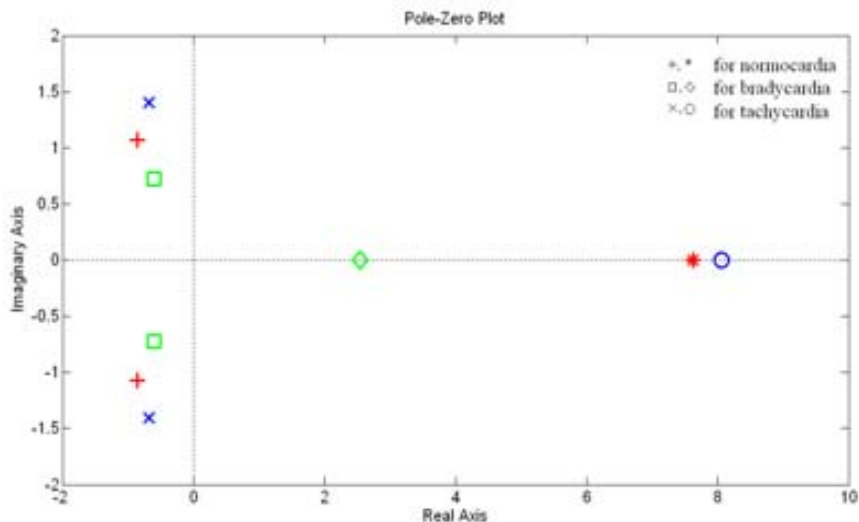

Figure 3.11 The pole-zero plot of normocardia, bradycardia and tachycardia.

Note: Plus and star denote poles and zero of normocardia, square and diamond in bradycardia case, and x-mark and circle in tachycardia case.

Normally, in detecting and diagnosing the cardiac abnormalities, small signals generated by a pacemaker to maintain a regular heartbeat are entrained by the real-time ECG signals measured inside the pacemaker. Conclusively, after the frequency entrainment, if pole-zero of the phase error between the measured ECG signals and entrained pacemaker-response satisfies all derived threshold conditions for bradycardia or tachycardia, the present heart rhythm is diagnosed as cardiac abnormality. Moreover, it is not a temporary or self-restored arrhythmia but a deadly abnormality falling into the dangerous zone. Thus, the regular pulses produced by the pacemaker are not able to help contractions resume their normal conditions. It is necessary to fire the pacemaker to generate compulsive strong signals, for assisting the heartbeat to restore to the normal.

3.4 Summary

This chapter describes the diagnosis of cardiac abnormalities based on frequency entrainment and pole-zero analysis. Instead of high cost and complicated multiple sensors, a novel algorithm to detect the pole-zero characteristics among normocardia, bradycardia, and tachycardia, is implemented to achieve a diagnostic pacemaker system for cardiac abnormalities.

In order to diagnose bradycardia and tachycardia, the thresholds of poles and zeros are derived for the first time in the study. From the simulation analysis, the proposed pole-zero threshold characteristics of cardiac abnormalities are able to complete a real-time diagnostic process for a pacemaker effectively. Application of the method in real-life treatment may achieve both human comfort level and energy saving requirements with more flexibility, comparing with a multiple sensor strategy. The results will be helpful not only for detection and analysis of cardiac abnormalities, but also for improvement of the performance of implantable pacemakers.

CHAPTER 4

FUZZY PID CONTROLLERS FOR DUAL-SENSOR CARDIAC PACEMAKER SYSTEMS

This chapter designs a fuzzy proportional-integral-derivative (FPID) controller for dual-sensor cardiac pacemaker systems, which can automatically control the heart rate to accurately track a desired preset profile. The combination of fuzzy logic and conventional PID control approaches is adopted for the controller design based on dual-sensors.

Due to the fuzzy or imprecise information of the physiological demand, the previous research (Johnson et al., 2003) has developed fuzzy logic controllers for the pacemaker systems. Over the past two decades, the field of fuzzy controller applications broadened to include many industrial controls (Wong et al., 2010), and significant research work supported the development of fuzzy controllers.

However, the conventional control algorithm based on fuzzy logic needs much improvement to achieve better adaptation of regulating the pacing rate to the physiological requirement for each particular patient. In addition, the mathematical complexity in the nonlinear fuzzy control makes the formulation of a tuning mechanism an extremely complex problem (Hung et al., 2008), (Karray et al., 2002).

Therefore, this study combines input variables with scaling factor of a PID controller and the fuzzy control mechanism for the dual-sensor cardiac pacemaker systems in patients with bradycardias for the first time, in which activity and QT interval are utilized as adaptive parameters.

4.1 Rate Regulation with Dual-Sensors

In order to estimate a patient's body conditions, e.g., rest, walk, or jog, and track all physiological changes well, the most common dual-sensors include the association of an accelerometer giving a rapid response for light or short duration of exercise and a QT interval for measurement of diagnostic data as detailed in (Shi & Zhou, 2011). They are adopted to provide activity signal and actual heart rate in this study.

Both sensors may control each other during crosscheck, and the output of heart rate is modified only if both or a predominant sensor agrees. For instance, after administration of a drug that shortens the QT interval, a QT interval sensor would indicate the need for rate increase; however, the rate would not change because the activity sensor is not triggered. Conversely, passively tapping on the device would activate the activity sensor and indicate a rate increase, but the rate would not be changed because the QT-interval sensor would not be stimulated by such maneuver (Shi & Zhou, 2011).

The pacemaker system in this study blends two sensor-rates at a certain percentage to obtain an optimized output rate. The following recommendations are made for a dual-sensor rate response (Shi & Zhou, 2011):

- 1) Except as otherwise recommended, the dual-sensor HR (heart rate) output should follow the QT interval indicated rate.
- 2) At the onset of walking, the dual-sensor HR output should follow the accelerometer indicated rate, but only up to 50% of the maximum rate elevation.
- 3) If the activity response is very low, and the QT interval response (Kligfield et al., 1996), (Mitchell et al., 1998) is very high, limit the dual-sensor rate response to

25% of the maximum rate elevation. This cross-checking prevents long-term pacing at high rates due to hyperventilation in a resting patient.

4.2 Conventional Control Scheme

In cases where the difference between the normal and abnormal in each of the conditions (e.g., rest, walking, or jogging) is not clear, such as in early detection of bradycardias, ambiguous information has to be dealt with. Thus, due to the ambiguity between the normal and abnormal estimation especially in medical assessment (Harinath & Mann, 2008), (Margaliot & Langholz, 1999), fuzzy controllers become a good candidate for accurate diagnosis and treatment. A fuzzy control system has the capability of transforming linguistic information and expert knowledge into control signals.

The main idea of fuzzy control systems is to design a controller for a system that is structurally difficult to model because of naturally existing nonlinearities and other modeling complexities (Sio & Lee, 1998), (Wang & Mendel, 1992). It offers a way to convert the verbal requirements to a numerical algorithm, and interpolates smoothly between the specified conditions. The significant and observable variables related to the control actions consist of fuzzy relationship or algorithm (Tao & Taur, 2000). The main advantage for these fuzzy systems is the simplicity of designing the system. It has been a successful implementation over traditional approaches such as adaptive control techniques.

Particularly, the conventional fuzzy control design in the model describes the correlation between the heart rate $HRS_j(t)$ of the patient at time t and the heart rate

provided by the pacemaker $HRT(t+)$. The fuzzy rules were formulated as in (Wojtasik et al., 2004)

$$\begin{aligned} & \text{if } HRS_j(t+) > HRS_j(t) + \Delta HR+ \\ & \text{then } HRT(t+) = \sum_j HRS_j(t+) + \Delta HR+(t+) \end{aligned} \quad (4.1)$$

$$\begin{aligned} & \text{if } HRS_j(t) + \Delta HR+ > HRS_j(t+) > HRS_j(t) + \Delta HR- \\ & \text{then } HRT(t+) = \sum_j HRS_j(t+) \end{aligned} \quad (4.2)$$

$$\begin{aligned} & \text{if } HRS_j(t+) < HRS_j(t) + \Delta HR- \\ & \text{then } HRT(t+) = \sum_j HRS_j(t+) + \Delta HR-(t+) \end{aligned} \quad (4.3)$$

$$\Delta HR+ = \max(j) \{ HRS_j(t+) - HR(t) \} \quad (4.4)$$

$$\Delta HR- = \min(j) \{ HRS_j(t+) - HR(t) \} \quad (4.5)$$

where $HR(t)$ is the desired heart rate of the patient at time t . $\Delta HR+$ and $\Delta HR-$ limit both the increase and decrease of heart rate, in order to avoid sudden heart rate changes.

Apparently, the conventional control scheme lacks detailed fuzzy rules to describe the control signal and pacing rate, according to diverse cases of the heart rate change. In addition, the conventional design is not able to solve the problem of adaptive control for the adjustable pacing rate, which means that it could not provide a synchronous tuning mechanism adaptive to the actual heart rate alteration. Accordingly, the conventional fuzzy system is not able to exhibit the preciseness of the actual heart rate change in real-time. Therefore, in order to solve the aforementioned problems and improve the

flexibility of the control system for easy personalization, this study proposes a novel design for the pacing system by combining fuzzy logic and well-formed formalism of PID control.

4.3 Fuzzy PID Controllers for Dual-Sensor Cardiac Pacemaker Systems

4.3.1 Design of FPID Controllers

Dual-sensor cardiac pacemakers become more and more sophisticated with the progress of electrophysiological and hemodynamic understanding of the heart as well as hardware/software technologies such as sensors and microprocessors. Such a pacing system requires a more flexible and powerful controller that has ability to be upgraded with the same hardware.

There are different types of FPID controllers (Li et al., 2001), (Mann et al., 2001). One of the earliest and very effective structures adopts a two-dimensional linear rule base with standard triangular membership functions, which combines fuzzy PI and fuzzy PD controllers. For conventional PID controllers, the control action is determined by performing arithmetic operations on error inputs. For another part-fuzzy control, the algebraic operations for fuzzy quantities have to be considered.

The FPID controller designed in this study is cascaded to the plant, i.e., human heart. As shown in Figure 4.1, there are three inputs for each fuzzy processing block (fuzzy channel), FC1 – FC3, in which FC denotes fuzzy channel. A fuzzy channel is a block where fuzzy reasoning is utilized. The corresponding normal heart rate recorded for each particular patient during rest, walking, and jogging is applied as the reference signal

or preset/desired profile, while the actual heart rate is measured in accordance with the dual-sensor rate response recommendations stated earlier.

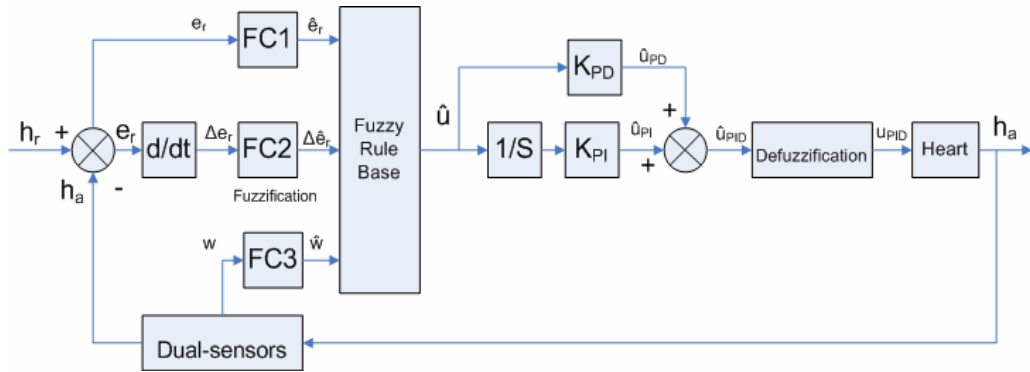

Figure 4.1 The design of fuzzy PID controller for dual-sensor cardiac pacemaker systems.

In Figure 4.1, the preset heart rate is denoted as the reference input h_r ; the output, actual heart rate, measured by dual-sensors as h_a ; and the error between h_r and h_a as e_r . The heart rate error e_r , change of error Δe_r and activity signal w are processed in the input fuzzy channels FC1 – FC3. Each channel produces its output \hat{e}_r , $\Delta\hat{e}_r$ and \hat{w} . In order to make them compatible with the fuzzy set representations in the rule base, the fuzzification module converts the inputs into members of fuzzy sets. It is performed by comparing numeric values of the HR error and the change of HR error against certain thresholds and assigning appropriate linguistic values to them. The error input provides the nonlinear proportional actions through fuzzy inference. After the fuzzy PI and fuzzy PD controllers, the defuzzified control signal u_{PID} , which is actually the pacing rate adjustable by the FPID controller and applied to the heart, is obtained (Shi & Zhou, 2011).

4.3.2 FPID Control Rules and Membership Functions

The fuzzy set of bradycardias is very strict in the sense that it cannot exhibit the impreciseness of the concept that is felt, if hesitating to classify an instance with the actual heart rate not exactly but nearing 60 bpm as a very clear case of bradycardias. For accommodating this fine imprecision of the heart rate error and the change of error, fuzzy rules should be allowed to vary smoothly by adding linguistic variables.

Fuzzy rules represent the linguistic descriptions of human expertise in controlling a process. This knowledge base is applied in an inference mechanism, in conjunction with some knowledge of the process states in order to determine control actions. The fuzzy rule bases for the heart rate interpretation are defined through using linear rules to form a fuzzy production system that employs generalized modus ponens (GMP) (Tsukamoto, 2009). GMP is a categorical inference rule, offered by fuzzy logic – to achieve approximation in drawing inferences when the existing rule base is found to be incomplete and inexact with respect to finer variations of actual heart rate from the feedback (Shi & Zhou, 2011).

Specifically, most patients with bradycardias achieve normal heart rates of 70 to 95 bpm, 85 to 90 bpm with a casual walk, 100 to 110 bpm with a brisk walk, and 105 to 130 bpm with a jogging (Hayes et al., 2000). In order to take care of finer variations in the heart rate patterns, the novel system equipped with GMP can perform qualified diagnosis as follows. Here, for instance, an average heart rate of 82.5 to 107.5 bpm at rest is expressed in the form of LH for “a little high”, VH for “very high”, and EH for “extremely high”. Thus, nine linguistic variables are utilized.

The nonlinearity in the control signal is achieved by modifying the variables

associated with membership functions. For activity signals, fuzzy set w for a patient at rest is assigned a membership value 0 based on the detection result of dual-sensors, for walk assigned a membership value 0.5, and for jogging a membership value 1. The membership function, denoted by μ_w for the fuzzy set w , can have 0, 0.5, or 1 value for any element of its domain of discourse, expressed as $\mu_w \in \{0, 0.5, 1\}$. Using these variables, several control rules are described as follows. A number of such rules covering all possible signal levels are formulated. The fuzzy rule bases of the FPID system are illustrated in Table 4.1. The meaning of the linguistic variables is explained in Table 4.2.

Table 4.1 Fuzzy Rule Bases of the FPID System

(a) $w = 0$

Δe_r e_r	VL	LL	N	LH	VH
VL	EL	VL	LO	LL	N
LL	VL	LO	LL	N	LH
N	LO	LL	N	LH	MH
LH	LL	N	LH	MH	VH
VH	N	LH	MH	VH	EH

(b) $w = 0.5$

Δe_r e_r	VL	LL	N	LH	VH
VL	EL	EL	VL	LO	LL
LL	EL	VL	LO	LL	N
N	VL	LO	LL	N	LH
LH	LO	LL	N	LH	MH
VH	LL	N	LH	MH	VH

(C) $w = 1$

Δe_r e_r	VL	LL	N	LH	VH
VL	EL	EL	EL	VL	LO
LL	EL	EL	VL	LO	LL
N	EL	VL	LO	LL	N
LH	VL	LO	LL	N	LH
VH	LO	LL	N	LH	MH

Table 4.2 Meaning of the Linguistic Variables

EL	Extremely Low	LH	A Little High
VL	Very Low	MH	High
LO	Low	VH	Very High
LL	A Little Low	EH	Extremely High
N	Normal		

Several examples of the fuzzy rules in Table 4.1 are as follows:

if w is 0 and e_r is VL and Δe_r is LL, then \hat{u} is VL. (4.6)

if w is 0 and e_r is LH and Δe_r is LH, then \hat{u} is MH. (4.7)

if w is 0 and e_r is LL and Δe_r is LH, then \hat{u} is N. (4.8)

if w is 0.5 and e_r is LL and Δe_r is N, then \hat{u} is LO. (4.9)

if w is 0.5 and e_r is VH and Δe_r is LH, then \hat{u} is MH. (4.10)

if w is 0.5 and e_r is VL and Δe_r is VH, then \hat{u} is LL. (4.11)

if w is 1 and e_r is VL and Δe_r is VL, then \hat{u} is EL. (4.12)

if w is 1 and e_r is LH and Δe_r is VH, then \hat{u} is LH. (4.13)

if w is 1 and e_r is LL and Δe_r is LH, then \hat{u} is LO. (4.14)

where \hat{u} is the corresponding fuzzy pacing rate after the fuzzification. The linguistic variables for fuzzy rate output indicate the intensity of the stimuli with adjustable pacing rate generated by the pacemaker.

With the exception of the membership functions on both ends of the input which are trapezoidal, the membership functions that cover the interior of the input space have the triangular shapes. Hence, as shown in Figure 4.2, the membership functions used in the calculation of fuzzy pacing rate are isosceles triangles with the same bases.

The membership functions are used to map from an input variable to a fuzzy one and from a fuzzy variable to the output. The composed fuzzy PI and PD actions for determining the fuzzy PID pacing rate are given by

$$\hat{u}_{PID} = K_{PD} \hat{u} + K_{PI} \int_0^1 \hat{u} \quad (4.15)$$

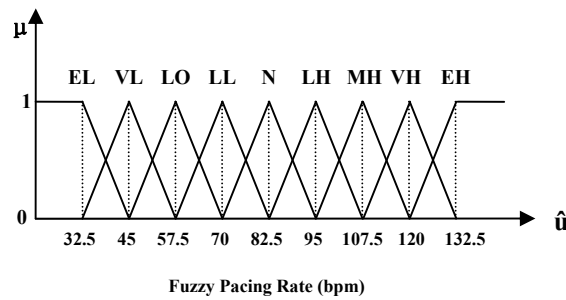

(a) Membership functions of fuzzy pacing rate at rest ($w = 0$).

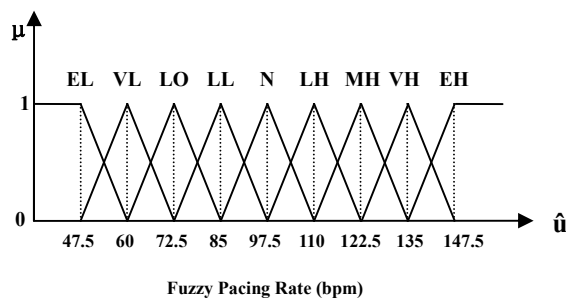

(b) Membership functions of fuzzy pacing rate during walking ($w = 0.5$).

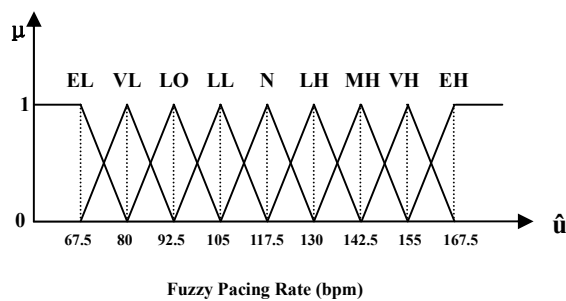

(c) Membership functions of fuzzy pacing rate during jogging ($w = 1$).

Figure 4.2 The membership functions.

In addition to the above, the fuzzy PID pacing rate is then defuzzified using the standard center of area method (Mohan & Patel, 2002) to yield the subsequent pacing rate provided by the pacemaker and apply to the heart corresponding to the current actual heart rate.

$$u_{PID} = \frac{\sum_i \mu_i \hat{u}_{PID}}{\sum_i \mu_i} \quad (4.16)$$

For the patient with bradycardia at rest, if the actual heart rate measured by dual-sensors is lower than the preset normal rate for the particular patient, the stimuli with adjustable pacing rate are generated by the pacemaker to assist the heartbeat to become regular, according to the FPID controller, such that the actual heart rate may track the preset desired heart rate in real-time.

4.4 Case Studies and Simulation Results

The closed-loop control of biological systems permits the tight regulation and instantaneous determination of the physiological state or response for automated computer-mediated interaction with cardiac tissues (Whittington et al., 2005). The FPID control system described in this thesis achieves the closed-loop control of a cardiac SA nodal cell and the system parameters for controlling variables to determine the pacing rate and achieve the desired response.

In designing a control system, the second step is to obtain a mathematical model of the plant for the controller. The case studies in this section adopt medical data sets of particular patients for simulation on the YNI model are implemented, in order to demonstrate the feasibility of the designed FPID controller for pacemaker systems. The tracking results are given in this section as well.

Alternately, the preset heart rate profile may be obtained by using the data from the same patient while recorded in a normal state or, if not possible, from the normal subjects of almost the same age and performing the similar daily activities, or the data

from other patients of the same pathological background.

In the FPID based cardiac pacemaker system, the patient's heart performance is then simulated by using the medical data sets, as the reference signal or preset/desired heart rate profile, from (Aboyans et al., 2008), (Blaufox et al., 2008), (Ferro et al., 2003), (Lemura et al., 2000), (Tammik & Jurimae, 1997), based on the YNI heart model. Table 4.3 (Shi & Zhou, 2011) presents the characteristics of individual patients and the corresponding preset HR during rest, walking, and jogging. The comparison between the FPID controller and conventional fuzzy control algorithm in (Wojtasik et al., 2004) are performed, in order to reveal the advantages and accuracy of an FPID control system.

Table 4.3 Individual Characteristics of Particular Patients

Case	Age (yr)	Sex	State	Preset HR (bpm)
I	66	Female	at rest	81±5
			walking	94±5
			jogging	107±5
II	54	Male	at rest	89±5
			walking	98±5
			jogging	113±5
III	48	Male	at rest	90±5
			walking	100±5
			jogging	120±5
IV	45	Female	at rest	92±5
			walking	103±5
			jogging	122±5

For the particular patients with bradycardias at rest, walking, and jogging, the tracking performances of FPID controlled HR and fuzzy controlled HR to the preset HR in the case studies are compared, respectively, in Figures 4.3-4.6. From the simulation results, the overall tracking and agreement of the rates with FPID is more effective for heartbeat recovery and maintenance than that with a conventional fuzzy control approach as stated above. Moreover, the response speed is much faster in the FPID system as well.

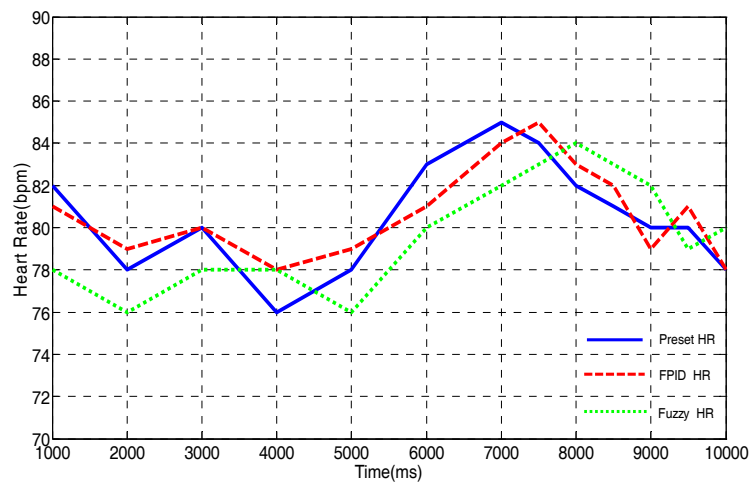

(a) At rest.

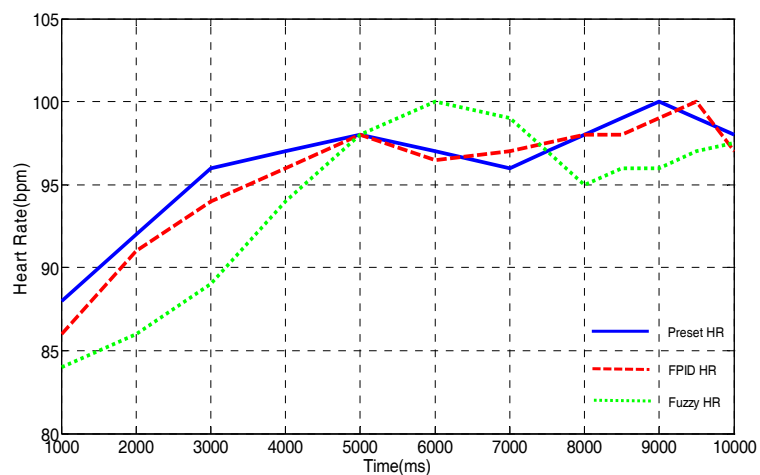

(b) While walking.

Figure 4.3 The heart rate tracking for Case I.

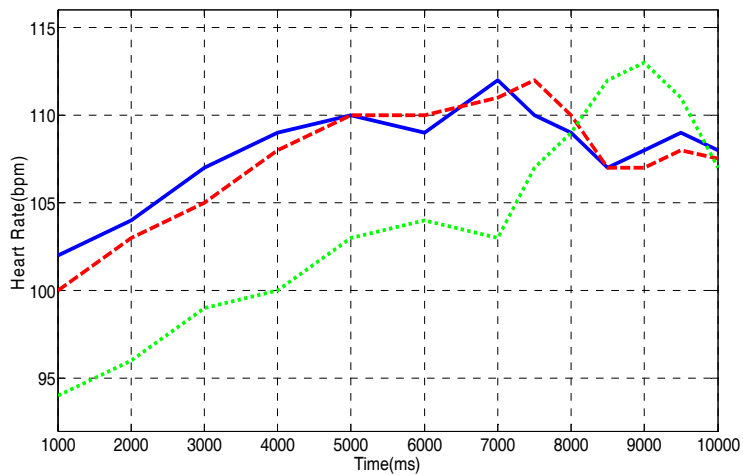

(c) While jogging.

Figure 4.3 The heart rate tracking for Case I (continued).

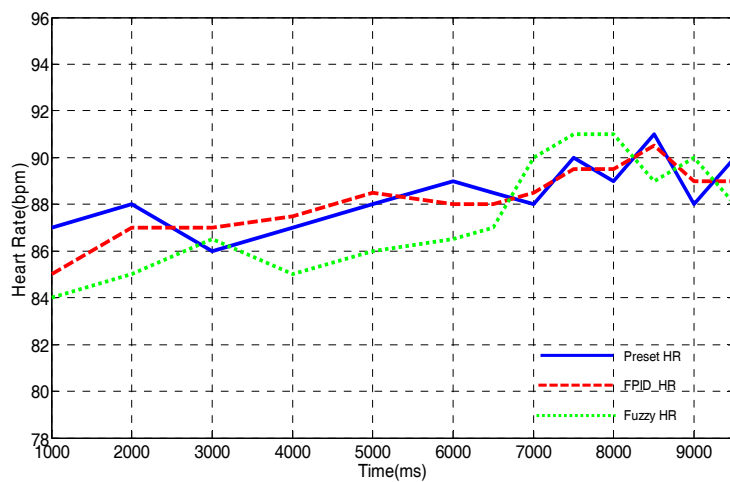

(a) At rest.

Figure 4.4 The heart rate tracking for Case II.

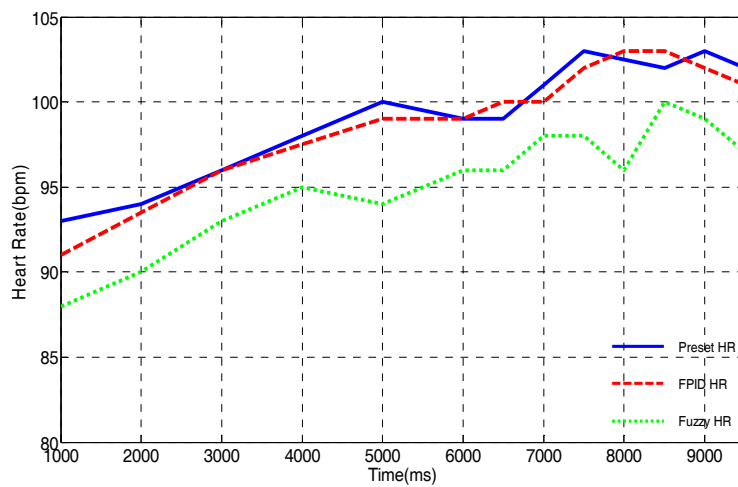

(b) While walking.

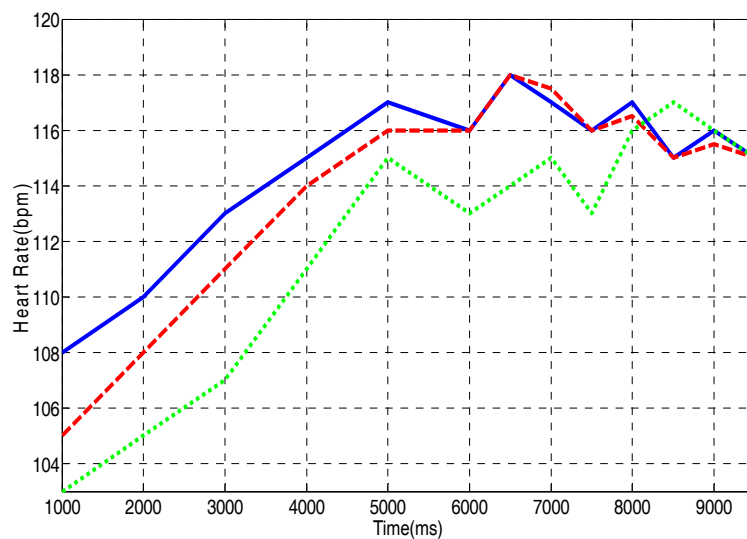

(c) While jogging.

Figure 4.4 The heart rate tracking for Case II (continued).

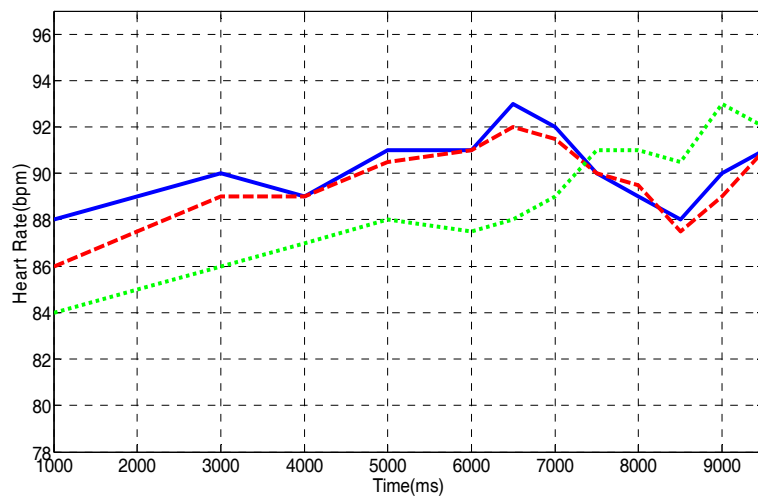

(a) At rest.

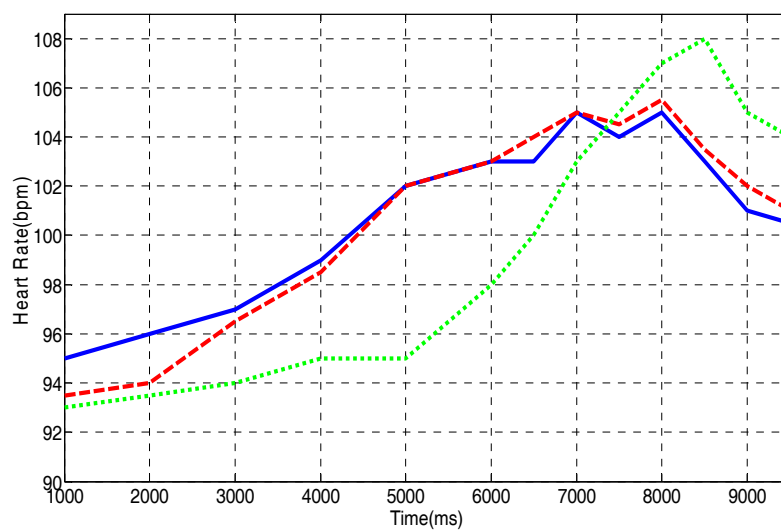

(b) While walking.

Figure 4.5 The heart rate tracking for Case III.

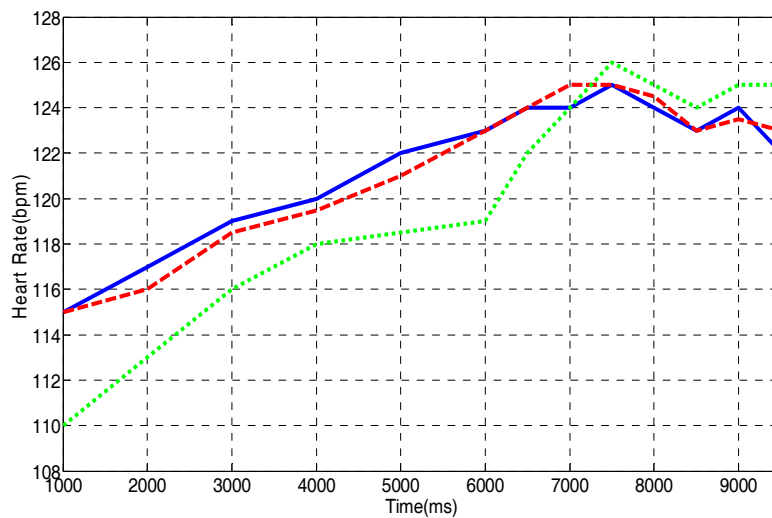

(c) While jogging.

Figure 4.5 The heart rate tracking for Case III (continued).

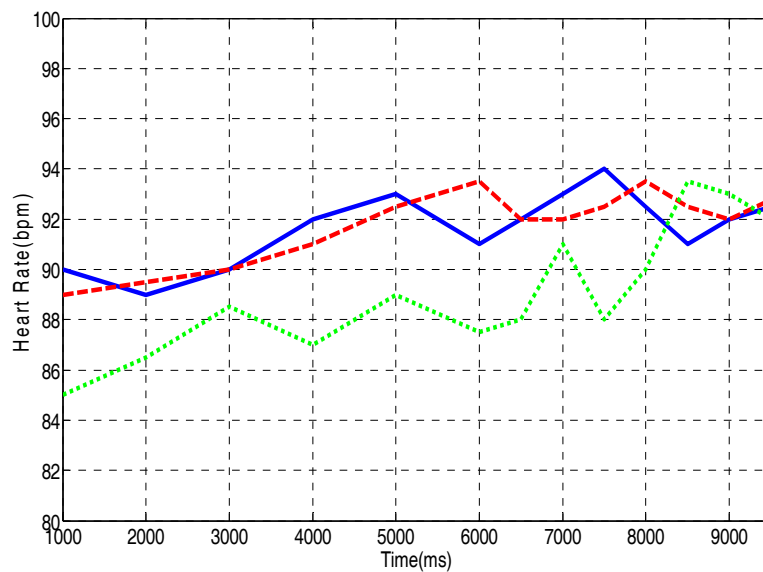

(a) At rest.

Figure 4.6 The heart rate tracking for Case IV.

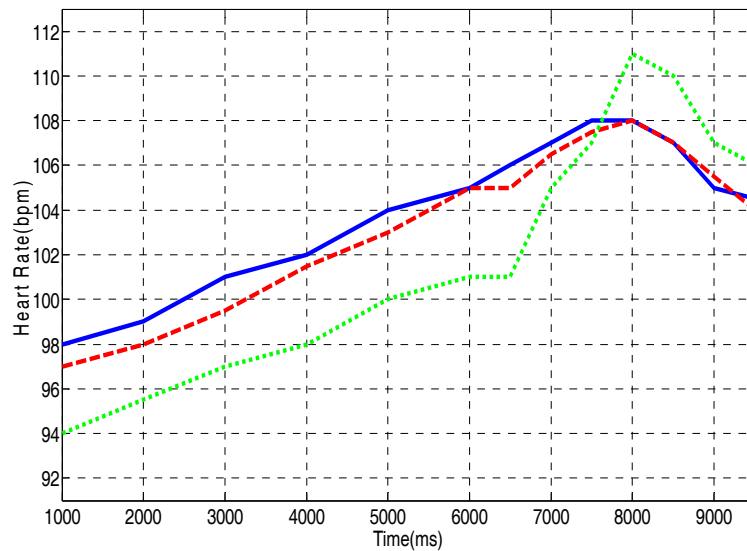

(b) While walking.

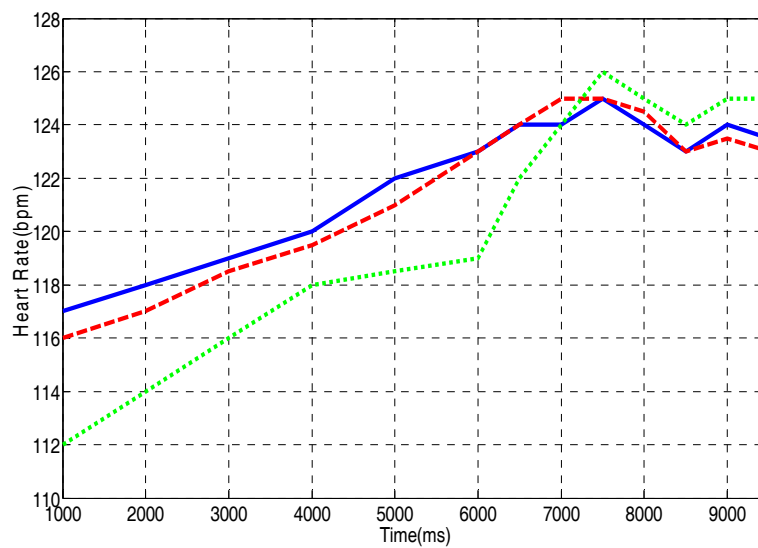

(c) While jogging.

Figure 4.6 The heart rate tracking for Case IV (continued).

The comparison of simulation results between the FPID controller and conventional fuzzy algorithm is demonstrated in Tables 4.4-4.7, including the root-mean-

square error (rmse) and the maximum error percent. Quite satisfactory tracking of the desired heart rate profile achieved with the FPID controller exhibits that the novel control design decreases rmse and maximum error, increases the accuracy of tracking and response speed, and improves the real-time adaptation of heart rate variation.

Table 4.4 Comparison of Simulation Results between the Novel FPID Controller and Conventional Fuzzy Control Algorithm in Case I

(a) Rest

	rmse	Maximum error
FPID	1.1902	2.63 %
Fuzzy	2.3805	4.88 %

(b) Walking

	rmse	Maximum error
FPID	1.1365	2.27 %
Fuzzy	3.7221	7.29 %

(c) Jogging

	rmse	Maximum error
FPID	1.2666	1.96 %
Fuzzy	6.4031	8.26 %

Table 4.5 Comparison of Simulation Results between the Novel FPID Controller and Conventional Fuzzy Control Algorithm in Case II

(a) Rest

	rmse	Maximum error
FPID	0.9094	2.30 %
Fuzzy	2.0709	3.45 %

(b) Walking

	rmse	Maximum error
FPID	0.9507	2.15 %
Fuzzy	4.2449	6.34 %

(c) Jogging

	rmse	Maximum error
FPID	1.2326	2.77 %
Fuzzy	3.3855	5.31 %

Table 4.6 Comparison of Simulation Results between the Novel FPID Controller and Conventional Fuzzy Control Algorithm in Case III

(a) Rest

	rmse	Maximum error
FPID	0.8880	2.33 %
Fuzzy	3.1440	5.38 %

(b) Walking

	rmse	Maximum error
FPID	0.8660	2.08 %
Fuzzy	3.7262	6.86 %

(c) Jogging

	rmse	Maximum error
FPID	0.6202	1.71 %
Fuzzy	2.7631	4.35 %

Table 4.7 Comparison of Simulation Results between the Novel FPID Controller and Conventional Fuzzy Control Algorithm in Case IV

(a) Rest

	rmse	Maximum error
FPID	1.0863	2.13 %
Fuzzy	3.4696	6.45 %

(b) Walking

	rmse	Maximum error
FPID	0.7596	1.47 %
Fuzzy	3.3570	4.08 %

(c) Jogging

	rmse	Maximum error
FPID	0.6355	1.71 %
Fuzzy	2.6675	4.27 %

Based on the simulation results, the FPID pacing system is more stable in the whole process, while tracking the preset HR in comparison of a conventional fuzzy control algorithm. Especially when the patient is taking a walk and jogging, the conventional fuzzy control is not able to achieve synchronously the physiological demands in body state change. In order to accommodate the fine imprecision of the heart rate, the designed fuzzy rules are set to be allowed for smooth variation by adding sufficient linguistic variables. Further, it may achieve an optimal pacing rate of pacemakers, through tuning the parameters of the PID controller flexibly and easily. Besides, simultaneous monitoring of several sensor signals is beneficial for additional functions which might be realized more easily and flexibly by the FPID as well.

Conclusively, the novel method is proved to be very promising for heart rate control in a dual-sensor pacing system.

4.5 Summary

In this chapter, a fuzzy PID controller for the heart rate control based on dual-sensor (accelerometer and QT interval) pacemaker systems is designed. Its feasibility and efficiency of automated rate regulation are demonstrated. Through comparing with the conventional fuzzy control algorithm, a fuzzy PID controller provides a more suitable control strategy to determine a pacing rate, in order to achieve a closer match between actual heart rate and a desired profile and provide a faster response speed in the cases of rest, walking, and jogging. Based on the simulation results, it has been proved that the FPID control system is more effective for heartbeat recovery, maintenance and real-time cardiac monitoring than a conventional fuzzy control system. Satisfactory heart rate tracking results with FPID are achieved by utilizing the individual patient's medical data sets.

CHAPTER 5

OPTIMAL SINGLE-PULSE FOR PACEMAKERS

This chapter designs an optimal single-pulse stimulus in pacemakers for treating sudden cardiac arrest, while minimizing the pulse amplitude and reducing the delivered energy. Based on the YNI model that describes the potential behavior of a sinoatrial node in a heart, it develops the frequency entrainment between irregular YNI-response and proposed single-pulse. The study derives the minimum amplitude of the optimal single-pulse for successful entrainment.

5.1 Introduction

Cardiac arrest is one of the leading causes of sudden cardiac death, which hovers menacingly over patients (Anderson, 2005). It is the cessation of normal circulation of the blood due to failure of the heart to contract effectively and it strikes people to death without any forebode, whether or not they have a diagnosed heart condition (Sthlberg et al., 2011).

One of the therapies to recover a victim's rhythm from cardiac arrest is to deliver the electrical pulse, which is well proved as the most effective therapy for cardiac arrest (Lim et al., 2008). A small battery-powered electrical pulse generator inside the pacemaker is implanted in patients who are at risk of sudden cardiac death due to cardiac arrest. Since a pacemaker's battery life is principally dependent on energy consumption, higher delivered energy for stimulation causes higher energy consumption in pacemakers and accelerates battery depletion. Furthermore, fast battery depletion necessitates pulse

generator replacements frequently for patients with implantable pacemakers. Meanwhile, because of the downsizing of pacemaker devices, the consecutive reduction of battery size, and the implementation of more sophisticated diagnostic features, continuous efforts have been made to reduce delivered energy and prolong the battery life (Berger et al., 2003).

5.2 Algorithm Design

In this study, the frequency entrainment between a single-pulse stimulus and the YNI model denotes the entrainment between the stimulus generated by the pacemaker and potential activities of the heart. The case studies of an adult at rest are adopted to demonstrate this algorithm design, for which the normal heart rate ranges from 60 to 100 bpm in an average adult at rest.

Intense disturbance could force the oscillations to annihilation, for instance, sudden cardiac arrest may drive the heartbeat to cessation. Under this circumstance, external stimulus, a single-pulse generated by the pacemaker, would be able to frequency-entrain the annihilated oscillating system and compel it in restoring the original normal heart beating. In the simulation analysis, the YNI model is perturbed intensely by the ventricular fibrillation. Afterwards, sudden cardiac arrest is caused as shown in Figure 5.1. It is frequency-entrained by a single-pulse in Figure 5.2.

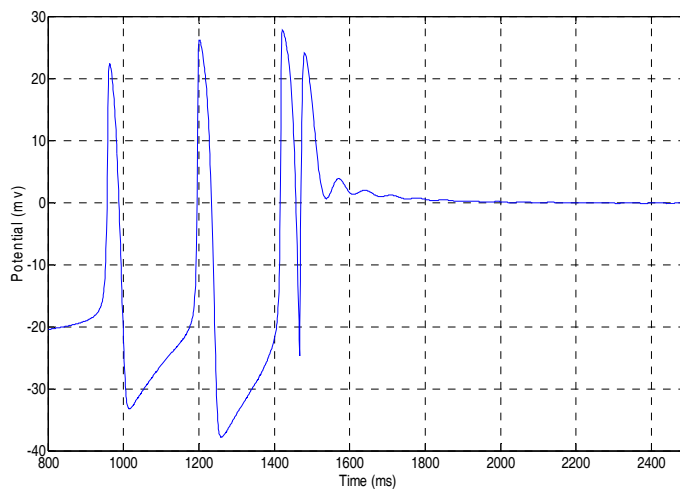

Figure 5.1 YNI-response under sudden cardiac arrest.

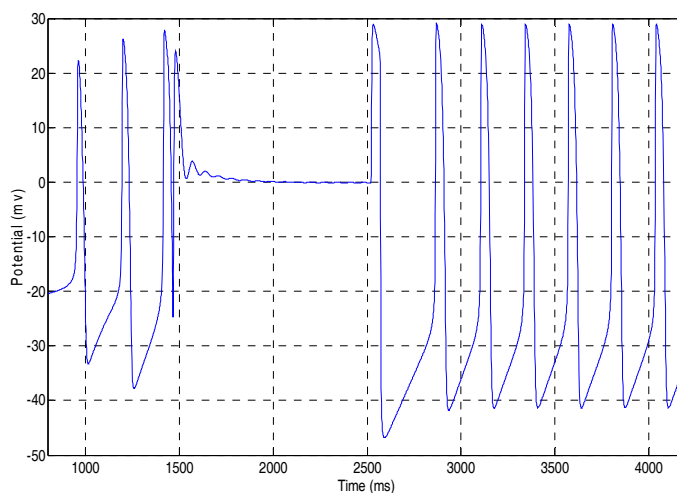

Figure 5.2 YNI-response in recovery from sudden cardiac arrest by single-pulse frequency entrainment.

After entrainment, the YNI model may fall into synchrony with the driving frequency. However, the delay before restoring normal heartbeat is very important for lifesaving that is determined by the single-pulse amplitude. For clinical applications, this process would depolarize a critical mass of the heart muscle, terminate the arrhythmia,

and allow normal sinus rhythm to be reestablished by the body's natural pacemaker, the SA node of a heart.

In order to accomplish successful frequency-entrainment, a minimum value for the single-pulse amplitude ($V_{p_{min}}$) is needed. If $V_p < V_{p_{min}}$, even longer duration is non-efficient to force the irregular oscillation back to normal as shown in Figure 5.3, in which V_p as the general pulse amplitude. Based on hundred times of simulation, the separatrix-voltage (V_s) of YNI-response required for successful entrainment is obtained for 1.295 mV (millivolt).

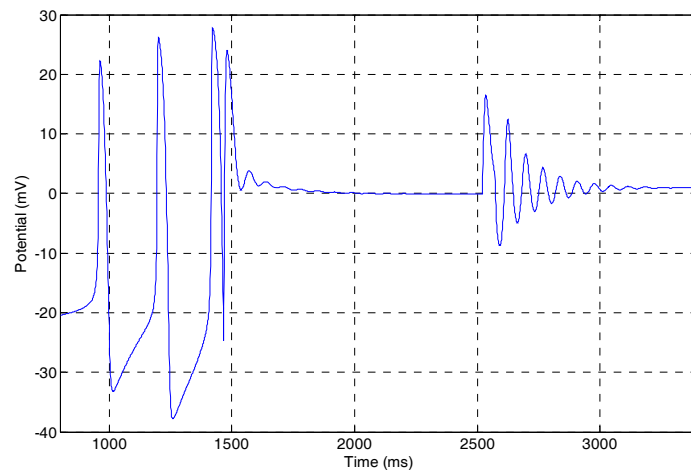

Figure 5.3 Unsuccessful entrainment under $V_p < V_{p_{min}}$.

Moreover, the energy consumption is a major determinant of the battery life and thus the overall pulse generator longevity inside the pacemakers. Therefore, frequency entrainment with the minimum energy becomes one of the most important engineering design goals. Although higher voltage, shorter duration may educe with lower energy, it may produce myocardial depression, tissue damage and may exceed voltage and current limitations of the components for the generator. Additionally, stimuli pain correlates with

peak voltage. As a result, the pulse voltage amplitude should be minimized and accord with the requisites of successful frequency entrainment.

In the following section, mathematical analysis has been performed to derive the optimal algorithm that may minimize the pulse amplitude and delivered energy required for successful frequency entrainment. To further illustrate the proposed algorithm, simulation has been carried out to verify the optimal strategy for such single-pulse stimulus.

5.3 Optimal Single-Pulse and Simulation Results

5.3.1 Optimal Single-Pulse

The stimuli-voltage as a function of time is straightly related to the pulse and delivered energy, which is concerned with pulse generator longevity (Kroll et al., 2007). Single-pulse amplitude is actually one of the main electrical parameters, which most directly influences the performance of the signal.

Alternately, the heart's response to a single-pulse occurs over a period that depends on the time constants of the cardiac cell membrane and possibly on other ionic, intracellular, cellular, and tissue properties. Thus, the optimal algorithm can be executed directly by borrowing mathematical techniques from optimal control theory.

In the manifestation of the mathematical model, a pulse current $I_p(t)$ is generated as the applied external current I_{app} . This pulse distributes throughout the heart such that the modeled region of myocardium is influenced by only some fraction of the source current. Accordingly, the YNI model (3.14) can be simplified as

$$C_m \frac{dV}{dt} + \frac{V}{R_m} = I_{app} = I_p(t) \quad (5.1)$$

where C_m and R_m are representations of the effective local myocardial membrane capacitance and resistance. Basically, the total energy delivered by a single-pulse can be calculated as

$$E = R_p \int_{t_1}^{t_2} (I_p(t))^2 dt = \int_{t_1}^{t_2} \frac{V_p^2}{R_p} dt \quad (5.2)$$

$$d_p = t_2 - t_1 \quad (5.3)$$

where R_p represents the effective pulse generator system resistance and d_p as the pulse duration.

As the plant equation (5.1) and performance index (5.2) subject to the appropriate boundary conditions, it can be solved to obtain the optimal correlation between single-pulse amplitude (V_p) and the delivered energy (E). Consequently, the surrogate control and differential equations for the optimization problem are

$$I_p(t) = \frac{V_p}{R_p} = -\left(\frac{1}{2R_p C_m}\right)\lambda \quad (5.4)$$

$$\frac{dV}{dt} = -\left(\frac{1}{\tau_m}\right)V - \left(\frac{1}{2R_p C_m^2}\right)\lambda \quad (5.5)$$

$$\frac{d\lambda}{dt} = \left(\frac{1}{\tau_m}\right)\lambda \quad (5.6)$$

where $\tau_m = R_m C_m$ as local myocardium time constant, and $\lambda(t)$ as intermediate variable.

Integration of Equations (5.5) and (5.6) is straightforward, and results in

$$V(t) = \left(K_1 + \frac{K_2 R_m}{4R_p C_m}\right) \exp\left(\frac{-t}{\tau_m}\right) - \frac{K_2 R_m}{4R_p C_m} \exp\left(\frac{t}{\tau_m}\right) \quad (5.7)$$

$$\lambda(t) = K_2 \exp\left(\frac{t}{\tau_m}\right) \quad (5.8)$$

$$V_p = -\left(\frac{1}{2C_m}\right)\lambda = -\frac{K_2}{2C_m} \cdot \exp\left(\frac{t}{\tau_m}\right) \quad (5.9)$$

where K_1 and K_2 are constants of integration.

Through combining equations (5.7) and (5.9), (5.10) is derived as

$$V(t) = \left(K_1 + \frac{K_2 R_m}{4R_p C_m}\right) \exp\left(\frac{-t}{\tau_m}\right) + \frac{R_m}{2R_p} \cdot V_p \quad (5.10)$$

Thus, the total energy delivered by a single-pulse follows directly from (5.2)

$$\frac{E}{R_p} = (t_2 - t_1) \cdot (I_p)^2 \quad (5.11)$$

$$E \cdot R_p = (t_2 - t_1) \cdot (V_p)^2 = d_p \cdot (V_p)^2 \quad (5.12)$$

According to Equation (5.12), the mathematical correlation between amplitude and delivered energy can be derived as follows. While the duration d_p retains 0.2-0.4 ms (millisecond) as previous studies (Barold et al., 1997), to minimize E , V_p is supposed to be an extremely low value which decreases monotonically along with energy. On the other hand, if sudden cardiac arrest occurs, the single-pulse amplitude has to be adequate to compel the irregular oscillation back to expected heart rhythm. Otherwise, if V_p is not sufficient to achieve $V_{p_{\min}}$, the perturbed YNI-response will finally converge to annihilation after a brief period of oscillations.

As specified above, the appropriate boundary conditions on $V(t)$ for this optimization problem are $V(t_1) = 0$ and $V(t_2) = V_0$, where V_0 denotes the initial voltage of the YNI-response when a single-pulse stops. Applying these boundary conditions to (5.8) and (5.10) thus yields specific equations that describe the myocardial voltage profile during that pulse ($t_1 \leq t \leq t_2$):

$$4K_1 R_p C_m + K_2 R_m = (-2\tau_m V_p) \cdot \exp\left(\frac{t_1}{\tau_m}\right) \quad (5.13)$$

$$V(t_2) = \left(\frac{R_m}{2R_p}\right) \cdot \left(1 - \exp\left(\frac{-d_p}{\tau_m}\right)\right) \cdot V_p \quad (5.14)$$

In order to complete successful frequency entrainment, the initial YNI-response ($V_0 = V(t_2)$) while a single-pulse ends at $t = t_2$ is supposed to be greater than or equal to the separatrix-voltage (V_s). Therefore, the ultimate case follows

$$V(t_2) = V_0 = V_s \quad (5.15)$$

$$\left(\frac{R_m}{2R_p}\right) \cdot \left(1 - \exp\left(\frac{-d_p}{\tau_m}\right)\right) \cdot V_{p\min} = V_s \quad (5.16)$$

The most commonly applied values of cardiac cell membrane in the previous studies of medical research have been estimated, for instance, time constant τ_m as 0.8 ms (Cleland, 1996), (Geddes et al., 1985), (Sweeney et al., 1996), R_m as the transmembrane resistance of an average adult being $20 \Omega (\pm 2 \Omega)$, due to temperature and other factors (Grant et al., 1982), (Luo et al., 1991), (Malkin et al., 2006), (Michaels et al., 1987), and R_p the effective resistance of a general pulse generator being 601Ω (Bauersfeld et al., 1999). As a result, $V_{p\min}$ and E are derived, respectively (Shi et al., 2011). A list of electrical parameters, delivered energy and delay for heart rhythm restoring is given in Table 5.1 hereinafter.

$$V_{p\min} = 197.8 \text{ mV } (\pm 18 \text{ mV}) \quad (5.17)$$

$$E = 0.026 \text{ } \mu\text{J } (\pm 0.005 \text{ } \mu\text{J}) \quad (5.18)$$

5.3.2 Simulation Results and Analysis

According to the inspection of the equations and results derived above, the corresponding simulation results are shown in Figures 5.4-5.7. Through Figures 5.4-5.6 of $V_p = V_{p\min} = 197.8 \text{ mV } (\pm 18 \text{ mV})$, the YNI-response ultimately restores regular heartbeat after injecting the optimized single-pulse.

However, in the case of $V_p < V_{p\min}$ as shown in Figure 5.7, the annihilation of disturbed YNI-response cannot be forced back to the expected heart rhythm. Ultimately, the heartbeat eventually decreases to almost zero after a temporary period of oscillations. Effectively, simulation results in Figures 5.4-5.7 verify the theoretical derivation of minimum single-pulse amplitude for successful frequency-entrainment in the optimal algorithm. Besides, based on the simulation, delay for resuming regular heartbeat takes about 94 ms. Hence, the optimal single-pulse with minimum amplitude is able to complete heartbeat recovery from sudden cardiac arrest, along with extremely low delivered energy and rapid response/short delay.

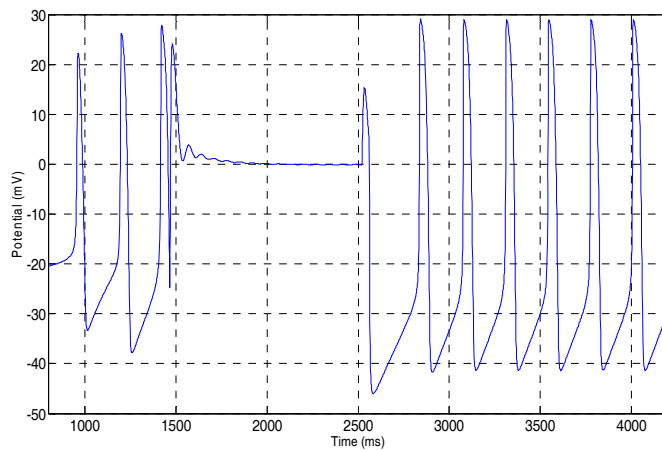

Figure 5.4 YNI-response frequency entrained by optimized single-pulse, while $V_P = V_{Pmin} = 179.8$ mV (197.8 – 18 mV).

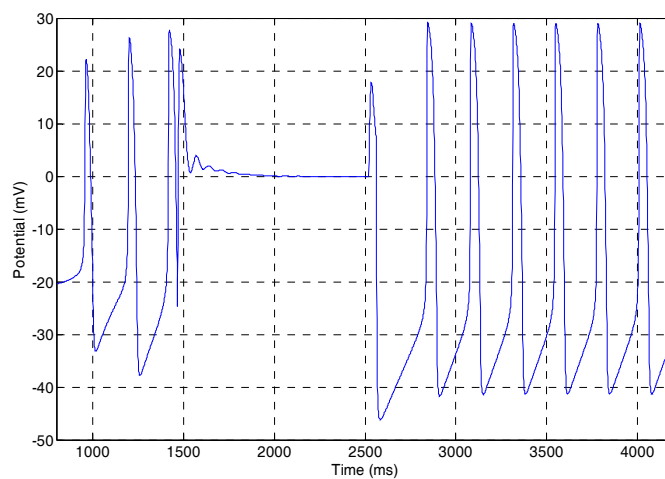

Figure 5.5 YNI-response frequency entrained by optimized single-pulse, while $V_P = V_{Pmin} = 197.8$ mV.

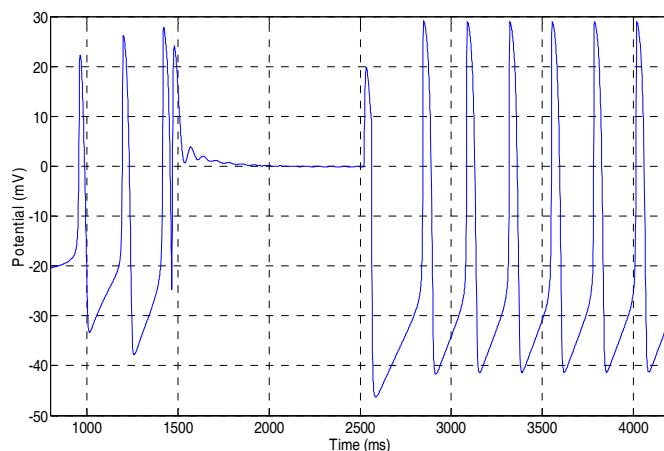

Figure 5.6 YNI-response frequency entrained by optimized single-pulse, while $V_P = V_{Pmin} = 215.8 \text{ mV}$ ($197.8 + 18 \text{ mV}$).

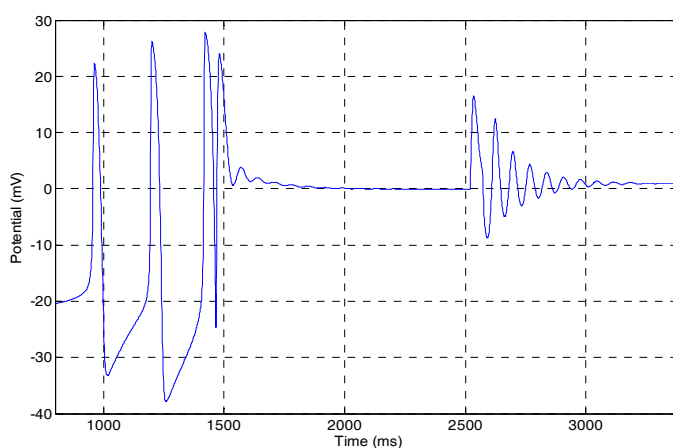

Figure 5.7 YNI-response unsuccessful frequency entrainment, while $V_P < V_{Pmin}$.

Table 5.1 provides the electrical parameters and delivered energy of the optimal single-pulse, while $V_P = V_{Pmin}$ and $V_P < V_{Pmin}$. Through the comparison of the optimal single-pulse and conventional pulse settings (Bauersfeld et al., 1999) in autocalculation in Table 5.2, the optimized pulse amplitude is much lower than conventional pulse and delivered energy in the optimization requires only $0.026 \mu\text{J}$ ($\pm 0.005 \mu\text{J}$), a reduction in energy of 91%. As one of the most popular pulse stimulations in pacemakers, an

autocapture system sets the output just above the measured threshold, ensuring the lowest energy level required for capture and thus optimizing device longevity. Nevertheless, according to the results in Table 5.2, there is marked improvement in energy consumption and decrease in pulse voltage amplitude, if the optimal single-pulse algorithm is utilized.

Table 5.1 Electrical Parameters and Energy of Optimal Single-pulse

	$V_P = V_{Pmin}$	$V_P < V_{Pmin}$
V_S (mV)	1.295	1.295
d_P (ms)	0.4	0.4
τ_m (ms)	0.8	0.8
R_m (Ω)	20 (± 2)	20 (± 2)
R_P (Ω)	601	601
V_P (mV)	197.8 (± 18)	170
E (μJ)	0.026 (± 0.005)	<i>N/A</i>
<i>delay</i> (ms)	94	<i>N/A</i>

Table 5.2 Comparisons between Optimal Single-pulse and Conventional Pulse Settings in Autocapture System

Parameter	Optimal Single-Pulse	Conventional Pulse
V_P (mV)	197.8 (± 18)	600
E (μJ)	0.026 (± 0.005)	0.3
d_P (ms)	0.4	0.49
R_P (Ω)	601	601

5.4 Summary

In this chapter, an optimal algorithm for single-pulse stimulus generated by a pacemaker is proposed. The minimum amplitude of this optimal single-pulse required for successful frequency entrainment is also derived, which is adequate to induce rapid response of sudden cardiac arrest for heartbeat recovery. The optimal algorithm and the minimum amplitude have been verified through the simulation analysis based on the YNI model. It has been shown that this optimal single-pulse is effective in heartbeat recovery while a reduction in delivered energy of 91%, comparing with a conventional pulse.

Essentially, the results will be helpful not only for healing of sudden cardiac arrest, but also for improvement of the implantable medical device performance, by prolonging battery and pulse generator longevity and releasing the stimuli pain on the patients.

CHAPTER 6

CONCLUSIONS AND FUTURE WORK

6.1 Contributions

This dissertation work proposes advanced intelligent controllers and optimization methods for cardiac pacemaker systems to diagnose deadly abnormalities accurately, recover heartbeat effectively, and prolong battery and pulse generator longevity and release the stimulus pain.

A comprehensive survey of biosensors used for pacemakers is provided in this work. The new features and advances of modern pacemakers are introduced. Furthermore, the advancement of varieties of biosensors incorporated in pacemakers is presented with their features and applications.

Instead of high-cost and complicated multiple-sensor-system, a diagnostic pacemaker system for cardiac abnormalities based on frequency entrainment and pole-zero analysis is achieved. The thresholds of poles and zeros to diagnose bradycardia and tachycardia are derived for the first time in the work. The proposed pole-zero threshold characteristics of cardiac abnormalities in this study are able to complete a real-time diagnostic process for a pacemaker effectively. The application of the proposed method to real-life treatment can achieve a desired human comfort level and meet energy saving requirements with more flexibility, contrasting with a multiple sensor strategy.

Second, a fuzzy proportional-integral-derivative (FPID) controller for the heart rate control based on dual-sensor pacemaker systems is designed. Its feasibility and efficiency of automated rate regulation are demonstrated. Comparing with the conventional fuzzy control, the proposed FPID provides a more suitable control strategy

to determine a pacing rate in order to achieve a closer match between actual heart rate and a desired profile in the cases of rest, walking, and jogging. It is more effective for heartbeat recovery, maintenance and real-time cardiac monitoring. Satisfactory heart rate tracking results with FPID are achieved by using an individual patient's medical data sets. The ability to track a predetermined heart rate profile is useful in cardiac rehabilitation programs or for safer daily life for individuals with bradycardias. Its application may not only bring more comfort for pacemaker patients, allowing them to be more physically active, but also improve the performance of the medical devices.

Finally, an algorithm for an optimal single-pulse stimulus generated by a pacemaker is proposed. The minimum amplitude of this optimal single-pulse for successful frequency-entrainment is also derived, which is adequate to induce the rapid response of sudden cardiac arrest for heartbeat recovery. The algorithm and the minimum amplitude have been proven by the simulation on the YNI model. It has been shown that the proposed optimal single-pulse is effective in heartbeat recovery while a 91% reduction in delivered energy is achieved in comparison with that of a conventional pulse. The results of this study will be helpful not only for healing sudden cardiac arrest but also for improving the performance of the implantable medical device, by prolonging battery and pulse generator longevity and releasing the stimulus pain.

6.2 Limitations

This research has the following limitations:

1. The simulation conditions, such as transmembrane resistance, are adopted based on the previously published papers. In clinical situations, the specialized

conduction system and transmembrane property of the heart are not the same among different individuals. The aforementioned characteristics would be altered by human health conditions and emotions. It is desired to build and use more realistic simulation data.

2. In the optimization of single-pulse, the pulse generator of a pacemaker may not always generate very accurate pulse amplitude. The sensitivity of the system performance needs to be investigated.
3. Design of desired implantable medical devices requires a tradeoff between the quality of operation of the device and its power consumption, i.e., its longevity in a human body after implantation. An FPID controller is complex and may need significant power to be operated. Its energy consumption issues should be addressed.

6.3 Future Work

There are several ways in which this work should be extended in the future. Some important and promising directions are listed as follows:

1. As mentioned in the limitations, the transmembrane property of the heart is not the same for different individuals and would be altered by human health conditions and emotions. The current research focuses on the cases of an average adult and the cardiac cell membrane resistance and other parameters are those most commonly used ones for medical research. Thus, adding more consideration of an individual patient's conditions is one of the important topics in the future research. More case studies need to be conducted for temperature or

environmental changes and a sudden increase or decrease of activity. In addition, the bio-sensing technology used for pacemakers requires deep theoretical and experimental investigations to decrease the complexity, as well as detect the individual transmembrane resistance.

2. Since the pulse generator might not give very accurate pulse amplitude, an algorithm needs to be developed to adjust the pulse amplitude to be the closest to the minimal voltage calculated. The related performance sensitivity issues should be addressed.
3. As an FPID controller is complex and needs large power to operate, improvement and simplification of the knowledge rules should be conducted to reduce power consumption and prolong the battery life. Meanwhile, design optimization could be incorporated into the controller design in the future research.
4. The remote monitoring for homecare and medical diagnoses on cardiac patients with pacemakers, incorporating with intelligent control systems and digital signal processor, is a promising research direction. Thus, the patient's information could be used as the medical and historical data in the processing stage. Additionally, in order to protect a patient's data from hackers, sensor systems with strong security features need to be developed.

REFERENCES

- Aboyans, V., Frank, M., Nubret, K., Lacroix, P., & Laskar, M. (2008). Heart rate and pulse pressure at rest are major prognostic markers of early postoperative complications after coronary bypass surgery. *European Journal of Cardiothoracic Surgery*, *33*, 971-976.
- Anderson, K.P. (2005). Sudden cardiac death unresponsive to implantable defibrillator therapy: An urgent target for clinicians, industry and government. *Journal of Interventional Cardiac Electrophysiology*, *14*, 71-78.
- Ang, K.H., Chong, G., & Li, Y. (2005). PID control system analysis, design, and technology. *IEEE Trans. Control Syst. Technol.*, *13*, 559-576.
- Arnaud, A., & Galup-Montoro, C. (2006). Fully integrated signal conditioning of an accelerometer for implantable pacemakers. *Analog Integrated Circuits and Signal Processing*, *49*, 313-321.
- Baig, M.W., Boute, W., & Begemann, M. (1988). Nonlinear relationship between pacing and evoked QT interval. *PACE*, 1804.
- Barold, S.S., Stokes, K., Byrd, C.L., & McVenes, R. (1997). Energy parameters in cardiac pacing should be abandoned. *PACE*, *20*, 112-121.
- Bauersfeld, U., Nowak, B., Molinari, L., Malm, T., Kampmann, C., Schonbeck, M.H., & Schuller, H. (1999). Low-energy epicardial pacing in children: The benefit of autocapture. *Annals of Thoracic Surgery*, *68*, 1380-1383.
- Beardsell, I., Bell, S., & Hulbert, D. (2009). *MCEM Part A: MCQs*. Royal Society of Medicine Press.
- Berger, T., Roithinger, F.X., Antretter, H., Hangler, H., Pachinger, O., & Hintringer, F. (2003). The influence of high versus normal impedance ventricular leads on pacemaker generator longevity. *PACE*, *26*, 2116-2120.
- Blaufox, A.D., Sleeper, L.A., Bradley, D.J., Breitbart, R.E., Hordof, A., Kanter, R.J., Stephenson, E.A., Stylianou, M., Vetter, V.L., & Saul, J.P. (2008). Functional status, heart rate, and rhythm abnormalities in 521 Fontan patients 6 to 18 years of age. *Journal of Thoracic and Cardiovascular Surgery*, *136*, 100-107.
- Bouallegue, S., Hagege, J., Ayadi, M., & Benrejeb, M. (2011). PID-type fuzzy logic controller tuning based on particle swarm optimization. *Engineering Applications of Artificial Intelligence*.

- Cakmakci, M., & Ulsov, G.A. (2009). Improving component-swapping modularity using bidirectional communication in networked control systems. *IEEE/ASME Trans. Mechatronics*, 14, 307-316.
- Cheng, X., Lei, Z., & Junqiu, Y. (2009). Fuzzy PID controller for wind turbines. *Intelligent Networks and Intelligent Systems*, 74-77.
- Cleland, B.G. (1996). A conceptual basis for defibrillation waveforms. *PACE*, 19, 1186-1195.
- Cloherty, S.L., Dokos, S., & Lovell, N.H. (2006). A comparison of 1-D models of cardiac pacemaker heterogeneity. *IEEE Trans. Biomed. Eng.*, 53, 164-177.
- Connelly, D.K. (1993). Initial experience with a new single chamber, dual sensor rate responsive pacemaker. *PACE*, 16, 1833-1841.
- Cooper, D. (1994). A dual-sensor rate-responsive pacemaker algorithm incorporating a fuzzy logic expert system. *Computers in Cardiology*, 73-76.
- Das, M.K., Dandamudi, G., & Steiner, H.A. (2009). Modern pacemakers: Hope or hype. *PACE*, 32, 1207-1221.
- Dell'Orto, S., Valli, P., & Greco, E. M. (2004). Sensors for rate responsive pacing. *Indian Pacing and Electrophysiology Journal*, 137-145.
- Demir, S.S., Clark, J.W., Murphey, C.R., & Giles, W.R. (1994). A mathematical model of a rabbit sinoatrial node cell. *Am. J. Physiol.*, 266, C832-C852.
- Dokos, S., Celler, B., & Lovell, N. (1996). Ion currents underlying sinoatrial node pacemaker activity: a new single cell mathematical model. *J. Theor. Biol.*, 181, 245-272.
- Duru, F., Radicke, D., Wilkoff, B.L., Cole, C.L., Adler, S., Nelson, L., Jensen, D.N., Strobel, U., Portzline, G., & Candinas, R. (2000). Influence of posture, breathing pattern, and type of exercise on minute ventilation estimation by pacemaker transthoracic impedance sensor. *PACE*, 1767-1771.
- Dutta, S.M., & Ghorbel, F.H. (2005). Differential hysteresis modeling of a shape memory alloy wire actuator. *IEEE/ASME Trans. Mechatronics*, 10, 189-197.
- Edgar, D.R., Horwood, J.K., Shaw, D.B., Woolons, D.J., & Baker, J. (1996). A multiple sensor recording pacemaker for diagnosis and research. *IEEE Engineering in Medicine and Biology Society*, 3, 1276-1277.
- Ferro, A., Duilio, C., Santomauro, M., & Cuocolo, A. (2003). Walk test at increased levels of heart rate in patients with dual-chamber pacemaker and with normal or depressed left ventricular function. *European Heart Journal*, 24, 2123-2132.

- Gardner, F.M. (2005). *Phaselock Techniques*. Hoboken, NJ: Wiley-Interscience.
- Geddes, L.A., & Bourland, J.D. (1985). Tissue stimulation: Theoretical considerations and practical applications. *Med. Biol. Eng. Comput.*, 23, 131-137.
- Grant, A.O., & Strauss, H.C. (1982). Intracellular potassium activity in rabbit sinoatrial node. Evaluation during spontaneous activity and arrest. *Circulation Research*, 51, 271-279.
- Greatbatch, W., & Holmes, C.F. (1991). History of implantable devices. *IEEE Engineering in Medicine and Biology Magazine*, 10, 38-49.
- Greco, E. M., & Romano, S. (2000). Rate responsive pacing: which sensor for which patient? Rhythm control from cardiac evaluation to treatment. *Southern Symposium on Cardiac Pacing*, 1, 277-283.
- Haddad, S. A. P., Houben, R. P. M., & Serdijin, W. A. (2006). The evolution of pacemakers. *IEEE Engineering in Medicine and Biology Magazine*, 25, 38-48.
- Harinath, E., & Mann, G.I. (2008). Design and tuning of standard additive model based fuzzy PID controllers for multivariable process systems. *IEEE Trans. Syst. Man, Cybern, B, Cybern.*, 38, 667-674.
- Hatzimichailidis, A.G., & Papadopoulos, B.K. (2008). Ordering relation of fuzzy implications. *Journal of Intelligent and Fuzzy Systems*, 19, 189-195.
- Hayashi, C., Shibayama, H., & Nishikawa Y. (1960). Frequency entrainment in a self-oscillatory system with external force. *IRE Trans. Circuit Theory*, 7, 413-422.
- Hayes, D.L., & Friedman, P.A. (2008). *Cardiac pacing defibrillation and resynchronization: A clinical approach*. Hoboken, NJ: Wiley-Blackwell.
- Hoeland, K., Kloppe, A., Hexamer, M., Nowack, G., & Werner, J. (2002). New sensor based on fiber optics for measurement of heart movement. *Medical & Biological Engineering & Computing*, 40, 571-575.
- Holzer, M., & Behringer, W. (2005). Therapeutic hypothermia after cardiac arrest. *Current Opinion in Anaesthesiology*, 18, 163-168.
- Hu, B.G., Mann, G.K., & Gosine, R.G. (2001). A systematic study of fuzzy PID controllers-function-based evaluation approach. *IEEE Trans. Fuzzy Syst.*, 9, 699-712.
- Hung, M.H., Shu, L.S., Ho, S.J., Hwang, S.F., & Ho, S.Y. (2008). A novel intelligent multiobjective simulated annealing algorithm for designing robust PID controllers. *IEEE Trans. Syst, Man, Cybern. A, Syst., Humans*, 38, 319-330.

- Johnson, P.L., Newton, J.C., Rollins, D.L., Smith, W.M., & Ideker, R.E. (2003). Adaptive pacing during ventricular fibrillation. *Pacing and Clinical Electrophysiology*, 26, 1824-1836.
- Josko, A., & Rak, R.J. (2005). Effective simulation of signals for testing ECG analyzer. *IEEE Trans. Instrumentation and Measurement*, 54, 1019-1024.
- Juang, J.G., Huang, M.T., & Liu, W.K. (2008). PID control using presearched genetic algorithms for a MIMO system. *IEEE Trans., Syst., Man, Cybern. C, Appl. Rev.*, 38, 716-727.
- Karray, F., Gueaieb, W., & Al-Sharhan, S. (2002). The hierarchical expert tuning of PID controllers using tools of soft computing. *IEEE Trans. Syst., Man, Cybern. B, Cybern.*, 32, 77-90.
- Keener, J., & Sneyd, J. (1998). *Mathematical Physiology*. New York: Springer.
- Khunnawat, C., Mukerji, S., Sankaran, S., & Thakur, R. K. (2005). Echocardiography induced tachycardia in a patient with a minute ventilation rate responsive pacemaker. *Journal of Interventional Cardiac Electrophysiology*, 14, 51-53.
- Kim, J.H., & Oh, S.J. (2000). A fuzzy PID controller for nonlinear and uncertain systems. *Soft Computing*, 4, 123-129.
- Kim, K., & Schaefer, R.C. (2005). Tuning a PID controller for a digital excitation control system. *IEEE Trans. Ind. Appl.*, 41, 485-492.
- Kligfield, P., Lax, K.G., & Okin, P.M. (1996). QT interval-heart rate relation during exercise in normal men and women: Definition by linear regression analysis. *Journal of the American College of Cardiology*, 28, 1547-1555.
- Kroll, M.W., & Swerdlow, C.D. (2007). Optimizing defibrillation waveforms for ICDs. *Journal of Interventional Cardiac Electrophysiology*, 18, 247-263.
- Lemura, L.M., Von Duvillard, S.P., & Mookerjee, S. (2000). The effects of physical training of functional capacity in adults. Ages 46 to 90: A meta-analysis. *Journal of Sports Medicine and Physical Fitness*, 40, 1-10.
- Li, L. (2011). The application of fuzzy PID controller in coupled-tank liquid-level control system. *International Conference on Electronics, Communications and Control*, 2894-2897.
- Li, W., Chang, X.G., Farrell, J., & Wahl, F.M. (2001). Design of an enhanced hybrid fuzzy PID controller for a mechanical manipulator. *IEEE Trans. Syst., Man, Cybern.*, 31, 938-945.

- Li, H.X., & Gatland, H.B. (1996). Conventional fuzzy control and its enhancement. *IEEE Trans. Syst., Man, Cybern. B, Cybern.*, 26, 791-797.
- Li, H.X., Zhang, L., Cai, K.Y., & Chen, G. (2006). An improved robust fuzzy-PID controller with optimal fuzzy reasoning. *IEEE Trans. Syst., Man, Cybern. B, Cybern.*, 35, 1283-1294.
- Lim, W.L., Hang, C.C., & Neo, K.B. (2008). Discontinuous innovations framework: A review of automatic external defibrillators in the healthcare industry. *Proc. IEEE Management of Innovation and Technology*, 356-361.
- Liu, X., Zheng, Y., Phyu, M. W., Zhao, B., Je, M., & Yuan, X. (2011). Multiple functional ECG signal is processing for wearable applications of long-term cardiac monitoring. *IEEE Trans. Biomed. Eng.*, 58, 380-389.
- Luo, C.H., & Rudy, Y. (1991). A model of the ventricular cardiac action potential. Depolarization, repolarization, and their interaction. *Circulation Research*, 68, 1501-1526.
- Malkin, R.A., Guan, D., & Wikswo, J.P. (2006). Experimental evidence of improved transthoracic defibrillation with electroporation-enhancing pulses. *IEEE Trans. Biomed. Eng.*, 53, 1901-1910.
- Mann, G.K., Hu, B.G., & Gosine, R.G. (2001). Two-level tuning of fuzzy PID controllers. *IEEE Trans. Syst., Man, Cybern. B, Cybern.*, 31, 263-269.
- Margaliot, M., & Langholz, G. (1999). Hyperbolic optimal control and fuzzy control. *IEEE Trans. Syst., Man, Cybern. A, Syst., Humans*, 29, 1-10.
- Michaels, D.C., Matyas, E.P., & Jalife, J. (1987). Mechanisms of sinoatrial pacemaker synchronization: A new hypothesis. *Circulation Research*, 61, 704-714.
- Mitchell, G.F., Jeron, A., & Koren, G. (1998). Measurement of heart rate and QT interval in the conscious mouse. *American Journal of Physiology Heart and Circulatory Physiology*, 274, H747-H751.
- Mohan, B.M., & Patel, A.V. (2002). Analytical structures and analysis of the simplest fuzzy PD controllers. *IEEE Trans. Syst., Man, Cybern. B, Cybern.*, 32, 239-248.
- Neumar, R.W., Otto, C.W., Link, M.S., & et al. (2010). Part 8: Adult advanced cardiovascular life support: 2010 American Heart Association Guidelines for Cardiopulmonary Resuscitation and Emergency Cardiovascular Care. *Circulation*, 122, S729-S767.
- Noble, D., DiFrancesco, D., & Denyer, J.C. (1989). Ionic mechanisms in normal and abnormal cardiac pacemaker activity. *Neuronal and Cellular Oscillators*, New York: Marcel Dekker, 59-85.

- Noble, D., & Noble, S. J. (1984). A model of sino-atrial node electrical activity based on a modification of the DiFrancesco-Noble equations. *Proc. R. Soc. Lond. B Biol. Sci.*, 222, 295-304.
- Ofoli, A., & Rubaai, A. (2006). Real-time implementation of a fuzzy logic controller for switch-mode power-stage DC-DC converters. *IEEE Trans. Ind. Appl.*, 42, 1367-1374.
- Okada, Y., Yamashiro, N., Ohmori, K., Masuzawa, T., Yamane, T., Konishi, Y., & Ueno, S. (2005). Mixed flow artificial heart pump with axial self-bearing motor. *IEEE/ASME Trans. Mechatronics*, 10, 658-665.
- Park, S.H., & Lee, C.W. (2010). Decoupled control of a disk-type rotor equipped with a three-pole hybrid magnetic bearing. *IEEE/ASME Trans. Mechatronics*, 15, 793-804.
- Petrutiu, S., Sahakian, A. V., Ricke, A., Young, B., & Swiryn, S. (2007). High resolution electrocardiography optimized for recording pulses from electronic pacemakers: Evaluation of a new pacemaker sensing system. *Computers in Cardiology*, 34, 197-200.
- Qi, J., & Liu, Y. (2010). PID control in adjustable-pitch wind turbine system based on fuzzy control. *International Conference on Industrial Mechatronics and Automation*, 2, 341-344.
- Qiu, L., & Yang, D. (2011). PID fuzzy control of activated sludge system. *Proceedings of International Conference on Electronics, Communications and Control*, 1573-1576.
- Rickards, A.F., & Norman, J. (1981). Relation between QT interval and heart rate. New design of physiologically adaptive cardiac pacemaker. *British Heart Journal*, 56-61.
- Rossi, P., Aina, F., Rognoni, G., Occhetta, E., Plicchi, G., & Prando, M. (1984). Increasing cardiac rate by tracking the respiratory rate. *PACE*, 1246-1256.
- Rubaai, A., Castro-Sitiriche, M.J., & Ofoli, A.R. (2008). DSP-Based laboratory implementation of hybrid fuzzy-PID controller using genetic optimization for high-performance motor drives. *IEEE Trans. Industry Applications*, 44, 1977-1986.
- Safar, P., Xiao, F., Radovsky, A., Tanigawa, K., Ebmeyer, U., Bircher, N., Alexander, H., & Stezoski, S.W. (1996). Improved cerebral resuscitation from cardiac arrest in dogs with mild hypothermia plus blood flow promotion. *Stroke*, 27, 105-113.

- Sarabia, J.A., Rol, M.A., Mendiola, P., & Madrid, J.A. (2008). Circadian rhythm of wrist temperature in normal-living subjects. A candidate of new index of the circadian system. *Physiology and Behavior*, 95, 570-580.
- Seidel, H., & Herzog, H. (1998). Analyzing entrainment of heartbeat and respiration with surrogates. *IEEE Engineering in Medicine and Biology Magazine*, 17, 54-57.
- Shepard, R.K., & Ellenbogen, K.A. (2009). Leads and longevity: How long will your pacemaker last. *Europace*, 11, 142-143.
- Shi, W.V., Chang, T.N., & Zhou, M.C. (2010). Method to detect cardiac abnormalities based on electrocardiography and sinoatrial pacemaker model. *Proc. IEEE Int. Conf. Mechatron. Autom.*, 566-571.
- Shi, W.V., & Zhou, M.C. (2011). Recent advances of sensors for pacemakers. *Proc. IEEE Int. Conf. Network., Sens. Control*, 520-525.
- Silva, G.J., Datta, A., & Bhattacharyya, S.P. (2002). New results on the synthesis of PID controllers. *IEEE Trans. Autom. Control*, 47, 241-252.
- Sio, K.C., & Lee, C.K. (1998). Stability of fuzzy PID controllers. *IEEE Trans. Syst., Man, Cybern. A, Syst., Humans*, 28, 490-495.
- Skoczowski, S., Domek, S., Pietruszewicz, K., & Plater, B. (2005). A method for improving the robustness of PID control. *IEEE Trans. Ind. Electron.*, 52, 1669-1676.
- Sthlberg, M., Kessels, R., Linde, C., & Braunschweig, F. (2011). Acute haemodynamic effects of increase in paced heart rate in heart failure patients recorded with an implantable haemodynamic monitor. *Europace*, 13, 237-243.
- Sweeney, R.J., Gill, R.M., Jones, J.L., & Reid, P.R. (1996). Defibrillation using a high-frequency series of monophasic rectangular pulses: Observations and model predictions. *J. Cardiovasc. Electrophysiol.*, 7, 134-143.
- Tammik, K., & Jurimae, T. (1997). Prediction of maximal oxygen uptake in middle-aged women using jogging and/or walking tests. *Biology of Sport*, 14, 311-317.
- Tao, C. W. (2002). A reduction approach for fuzzy rule bases of fuzzy controllers. *IEEE Trans. Syst., Man, Cybern., B, Cybern.*, 32, 668-675.
- Tao, C. W., & Taur, J.S. (2000). Flexible complexity reduced PID-like fuzzy controllers. *IEEE Trans. Syst., Man, Cybern., B, Cybern.*, 30, 510-516.
- Tsukamoto, Y. (2009). A normative approach to fuzzy logic reasoning using residual implications. *Journal of Advanced computational intelligence and intelligent informatics*, 13, 262-267.

- Wang, L.X., & Mendel, J.M. (1992). Generating fuzzy rules by learning from examples. *IEEE Trans. Syst., Man, Cybern.*, 22, 1414-1427.
- Whittington, R.H., Giovangrandi, L., & Kovacs, G.A. (2005). A closed-loop electrical stimulation system for cardiac cell cultures. *IEEE Trans. Biomed. Eng.*, 52, 1261-1270.
- Wilders, R., Jongsma, H.J., & Ginneken, A.G. (1991). Pacemaker activity of the rabbit sinoatrial node: a comparison of mathematical models. *Biophys. J.*, 60, 1202-1216.
- Wojtasik, A., Jaworski, Z., Kuzmicz, W., Wielgus, A., Walkanis, A., & Sarna, D. (2004). Fuzzy logic controller for rate-adaptive heart pacemaker. *Applied Soft Computing Journal*, 4, 259-270.
- Wong, W.K., Bai, E., & Chu, A.C. (2010). Adaptive time-variant models for fuzzy-time-series forecasting. *IEEE Trans. Syst., Man, Cybern., B, Cybern.*, 40, 1531-1542.
- Wood, M.A., & Ellenbogen, K.A. (2002). Cardiac pacemakers from the patient's perspective. *Circulation*, 105, 2136-2138.
- Woollons, D. J. (1995). To beat or not to beat: the history and development of heart pacemakers. *Engineering Science and Education Journal*, 4, 259-268.
- Yanagihara, K., Noma, A., & Irisawa, H. (1980). Reconstruction of sino-atrial node pacemaker potential based on the voltage clamp experiments. *Japanese Journal of Physiology*, 30, 841-857.
- Zemiti, N., Bricault, I., Fouard, C., Sanchez, B., & Cinquin, P. (2008). LPR: A CRT and MR-compatible puncture robot to enhance accuracy and safety of image-guided interventions. *IEEE/ASME Trans. Mechatronics*, 13, 306-315.
- Zhao, Z.Y., Tomizuka, M., & Isaka, S. (1993). Fuzzy gain scheduling of PID controllers. *IEEE Trans. Syst., Man, Cybern.*, 23, 1392-1398.