

ASRock®

X600-ITX

User Manual

Version 1.0

Published August 2023



This device complies with Part 15 of the FCC Rules. Operation is subject to the following two conditions:

- (1) this device may not cause harmful interference, and
- (2) this device must accept any interference received, including interference that may cause undesired operation.

CALIFORNIA, USA ONLY

The Lithium battery adopted on this motherboard contains Perchlorate, a toxic substance controlled in Perchlorate Best Management Practices (BMP) regulations passed by the California Legislature. When you discard the Lithium battery in California, USA, please follow the related regulations in advance.

“Perchlorate Material-special handling may apply, see www.dtsc.ca.gov/hazardouswaste/perchlorate”



AUSTRALIA ONLY

Our goods come with guarantees that cannot be excluded under the Australian Consumer Law. You are entitled to a replacement or refund for a major failure and compensation for any other reasonably foreseeable loss or damage caused by our goods. You are also entitled to have the goods repaired or replaced if the goods fail to be of acceptable quality and the failure does not amount to a major failure.

The terms HDMI™ and HDMI High-Definition Multimedia Interface, and the HDMI logo are trademarks or registered trademarks of HDMI Licensing LLC in the United States and other countries.



Contents

Chapter 1 Introduction	1
1.1 Package Contents	1
1.2 Specifications	2
1.3 Motherboard Layout	5
1.4 Front Panel	8
1.5 Rear Panel	9
Chapter 2 Installation	10
2.1 Installing the CPU	11
2.2 Installing the CPU Fan and Heatsink	14
2.3 Installing Memory Modules (DIMM)	16
2.4 Expansion Slot (PCIe Slot)	18
2.5 Jumpers Setup	19
2.6 Onboard Headers and Connectors	20
2.7 Smart Button	23
2.8 M.2 WiFi/BT Module Installation Guide	25
2.9 M.2 SSD Module Installation Guide	27
Chapter 3 Auto Driver Installer	29
Chapter 4 UEFI SETUP UTILITY	30
4.1 Introduction	30
4.1.1 UEFI Menu Bar	30
4.1.2 Navigation Keys	31
4.2 Main Screen	32

4.3	OC Tweaker Screen	33
4.4	Advanced Screen	36
4.4.1	CPU Configuration	37
4.4.2	PCI Configuration	38
4.4.3	Onboard Devices Configuration	39
4.4.4	Storage Configuration	40
4.4.5	ACPI Configuration	41
4.6.6	USB Configuration	43
4.4.7	Trusted Computing	44
4.6.8	AMD CBS	46
4.6.9	AMD PBS	47
3.4.10	AMD Overclocking	48
4.5	Tools	49
4.6	Hardware Health Event Monitoring Screen	50
4.7	Security Screen	52
4.8	Boot Screen	53
4.9	Exit Screen	55

Chapter 1 Introduction

Thank you for purchasing X600-ITX motherboard. In this documentation, Chapter 1 and 2 contains the introduction of the motherboard and step-by-step installation guides. Chapter 3 contains the operation guide of the software and utilities. Chapter 4 contains the configuration guide of the BIOS setup.



Because the motherboard specifications and the BIOS software might be updated, the content of this documentation will be subject to change without notice.

1.1 Package Contents

- X600-ITX Motherboard (Deep mini-ITX Form Factor)
- 1 x I/O Panel Shield
- 2 x SATA Cables (Optional)
- 2 x Screws for M.2 Sockets (M2*2) (Optional)
- 1 x Screw for WiFi Module (M2*2) (Optional)

1.2 Specifications

- Platform**
- Deep mini-ITX Form Factor
 - Solid Capacitor design

- CPU**
- Supports AMD Socket AM5 Ryzen™ 8000 and 7000 Series Processors
 - Supports CPU up to 65W
 - 6+2 Power Phase design

- Chipset**
- AMD X600

- Memory**
- Dual Channel DDR5 Memory Technology
 - 4 x DDR5 DIMM Slots
 - Supports DDR5 ECC/non-ECC, un-buffered memory up to 7200+(OC)*
 - Max. capacity of system memory: 192GB
 - Supports Extreme Memory Profile (XMP) and EXTended Profiles for Overclocking (EXPO) memory modules
- * Please refer to Memory Support List on ASRock's website for more information. (<http://www.asrock.com/>)

- Expansion Slot**
- CPU:
- 1 x PCIe 4.0 x16 Slot, supports x16 mode*
- * Supports NVMe SSD as boot disks
- 1 x M.2 Socket (Key E), supports type 2230 WiFi/BT module

- Graphics**
- Integrated AMD RDNA™ graphics (Actual support may vary by CPU)
 - Three graphics output options: 1x HDMI, 2 x DisplayPort 1.4
 - Supports Triple Monitor
 - 1 x HDMI 2.1 TMDS/FRL 8G Compatible, supports HDR, HDCP 2.3 and max. resolution up to 4K 120Hz
 - 2 x DisplayPort 1.4 with DSC (compressed), support HDCP 2.3 and max. resolution up to 4K 120Hz

- Audio**
- Realtek ALC897 Audio Codec

- LAN**
- 2.5 Gigabit LAN 10/100/1000/2500 Mb/s
 - Dragon RTL8125BG
 - Supports Dragon 2.5G LAN Software
 - Smart Auto Adjust Bandwidth Control
 - Visual User Friendly UI
 - Visual Network Usage Statistics
 - Optimized Default Setting for Game, Browser, and Streaming Modes
 - User Customized Priority Control

- Front Panel I/O**
- 1 x Headphone/Headset Jack
 - 2 x USB 3.2 Gen1 Type-A Ports
 - 1 x USB 3.2 Gen1 Type-C Port
 - 2 x USB 2.0 Ports

- Rear Panel I/O**
- 1 x HDMI Port
 - 2 x DisplayPort 1.4
 - 2 x USB 3.2 Gen1 Ports
 - 2 x USB 2.0 Ports
 - 1 x RJ-45 LAN Port
 - 1 x BIOS Flashback Button
 - HD Audio Jacks: Line in / Front Speaker / Microphone

- Storage**
- CPU:
- 1 x Blazing M.2 Socket (M2_1, Key M), supports type 2280 PCIe Gen5x4 (128 Gb/s) mode*
 - 1 x Hyper M.2 Socket (M2_2, Key M), supports type 2280 PCIe Gen4x4 (64 Gb/s) mode*
- ASMedia ASM1061:
- 2 x SATA3 6.0 Gb/s Connectors

* Supports NVMe SSD as boot disks

RAID

- Supports RAID 0, RAID 1 and RAID 10 for M.2 NVMe storage devices*
- * Requires additional M.2 NVMe expansion cards to support RAID 10

Connector

- 1 x Chassis Intrusion Header
 - 1 x CPU Fan Connector
- * The CPU Fan Connector supports the CPU fan of maximum 1A (12W) fan power.
- 1 x Chassis Fan Connector (4-pin)
- * The Chassis Fan Connector supports the chassis fan of maximum 1A (12W) fan power.
- 1 x 24 pin ATX Power Connector
 - 1 x 8 pin 12V Power Connector
 - 1 x Front Panel Header
 - 1 x USB 2.0 Header (Supports 2 USB 2.0 ports)

**BIOS
Feature**

- AMI UEFI Legal BIOS with GUI support

**Hardware
Monitor**

- CPU, Chassis Temperature Sensing
- CPU, Chassis Fan Tachometer
- CPU, Chassis Quiet Fan (Auto adjust chassis fan speed by CPU temperature)
- CPU, Chassis Fan Multi-Speed Control
- CASE OPEN detection
- Voltage monitoring: +12V, +5V, +3.3V, CPU Vcore

OS

- Microsoft® Windows® 10 64-bit

**Certifica-
tions**

- FCC, CE
- ErP/EuP ready (ErP/EuP ready power supply is required)



Please realize that there is a certain risk involved with overclocking, including adjusting the setting in the BIOS, applying Untied Overclocking Technology, or using third-party overclocking tools. Overclocking may affect your system's stability, or even cause damage to the components and devices of your system. It should be done at your own risk and expense. We are not responsible for possible damage caused by overclocking.

1.3 Motherboard Layout

Top Side View

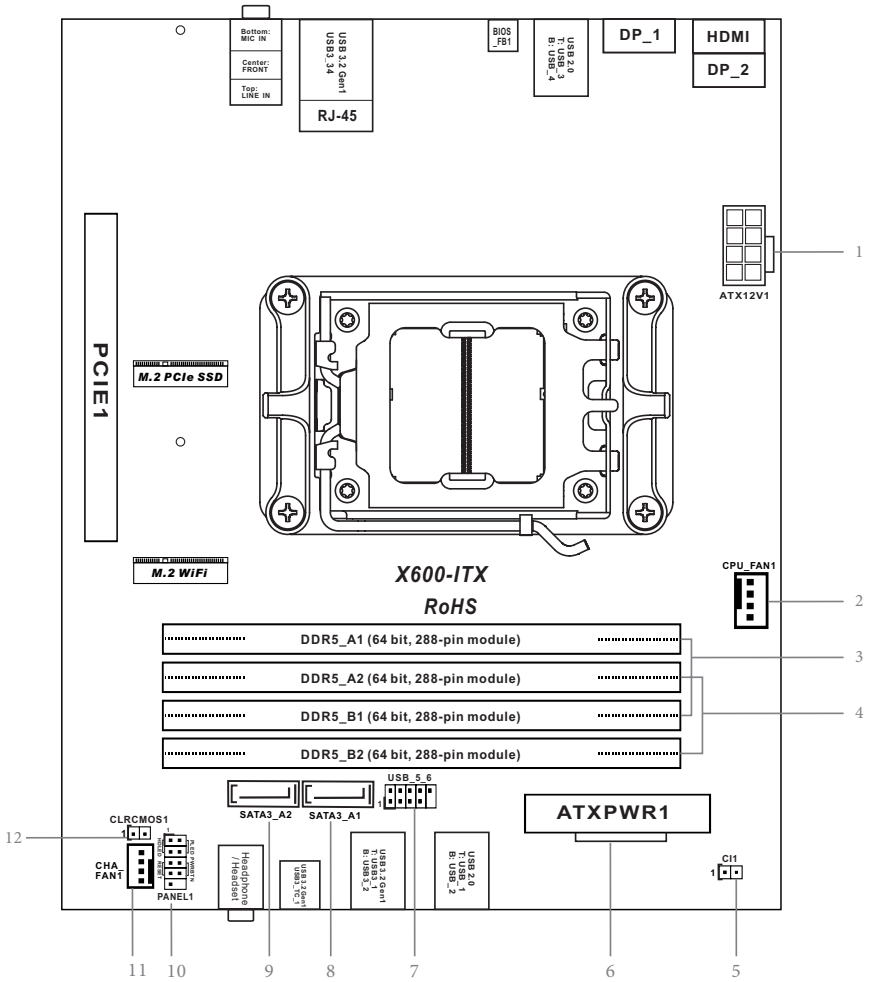

English

Back Side View

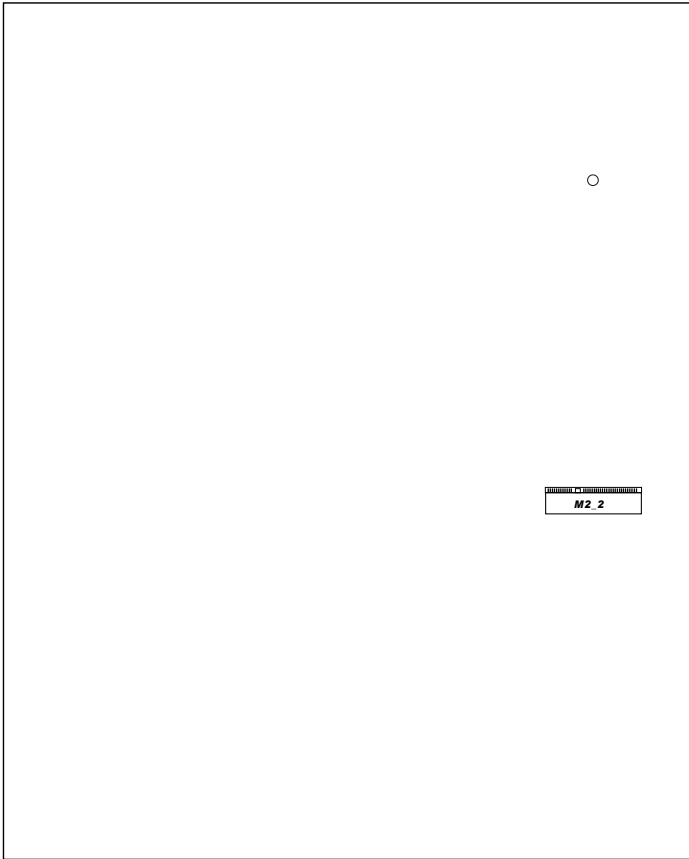

7

No.	Description
1	8 pin 12V Power Connector (ATX12V1)
2	CPU Fan Connector (CPU_FAN1)
3	2 x 288-pin DDR5 DIMM Slots (DDR5_A1, DDR5_B1)
4	2 x 288-pin DDR5 DIMM Slots (DDR5_A2, DDR5_B2)
5	Chassis Intrusion Header (CI1)
6	ATX Power Connector (ATXPWR1)
7	USB 2.0 Header (USB_5_6)
8	SATA3 Connector (SATA3_A1)
9	SATA3 Connector (SATA3_A2)
10	System Panel Header (PANEL1)
11	Chassis Fan Connector (CHA_FAN1)
12	Clear CMOS Jumper (CLRCMOS1)

1.4 Front Panel

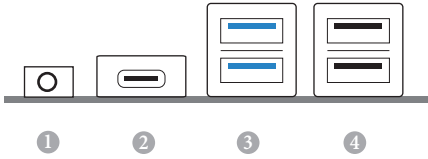

No.	Description	No.	Description
1	Headphone/Headset Jack (AUDIO1)	3	USB 3.2 Gen1 Type-A Ports (USB3_12)
2	USB 3.2 Gen1 Type-C Port (USB3_TC_1)	4	USB 2.0 Ports (USB_12)

1.5 Rear Panel

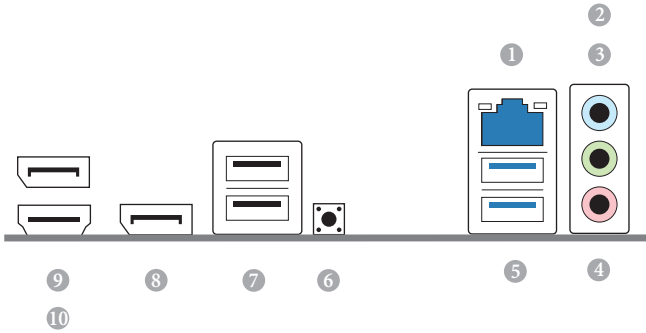

No.	Description	No.	Description
1	2.5G LAN RJ-45 Port*	6	BIOS Flashback Button
2	Line In (Light Blue)**	7	USB 2.0 Ports (USB_34)
3	Front Speaker (Lime)**	8	DisplayPort 1.4 (DP_1)
4	Microphone (Pink)**	9	DisplayPort 1.4 (DP_2)
5	USB 3.2 Gen1 Ports (USB3_34)	10	HDMI Port

* There are two LEDs on each LAN port. Please refer to the table below for the LAN port LED indications.

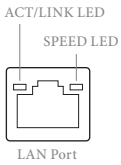

Activity / Link LED		Speed LED	
Status	Description	Status	Description
Off	No Link	Off	10Mbps connection
Blinking	Data Activity	Orange	100Mbps/1Gbps connection
On	Link	Green	2.5Gbps connection

Chapter 2 Installation

This is a Deep mini-ITX form factor motherboard. Before you install the motherboard, study the configuration of your chassis to ensure that the motherboard fits into it.

Pre-installation Precautions

Take note of the following precautions before you install motherboard components or change any motherboard settings.

- Make sure to unplug the power cord before installing or removing the motherboard. Failure to do so may cause physical injuries to you and damages to motherboard components.
- In order to avoid damage from static electricity to the motherboard's components, NEVER place your motherboard directly on a carpet. Also remember to use a grounded wrist strap or touch a safety grounded object before you handle the components.
- Hold components by the edges and do not touch the ICs.
- Whenever you uninstall any components, place them on a grounded anti-static pad or in the bag that comes with the components.
- When placing screws to secure the motherboard to the chassis, please do not over-tighten the screws! Doing so may damage the motherboard.

2.1 Installing the CPU



1. Before you insert the 1718-Pin CPU into the socket, please check if the **PnP cap** is on the socket, if the CPU surface is unclean, or if there are any **bent pins** in the socket. Do not force to insert the CPU into the socket if above situation is found. Otherwise, the CPU will be seriously damaged.
2. Unplug all power cables before installing the CPU.



Tutorial Video

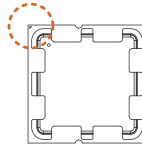
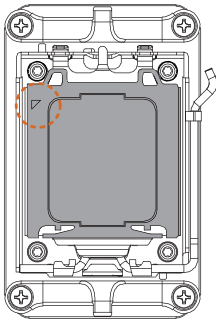

Turn your CPU to the correct orientation before opening the CPU socket cover.

1

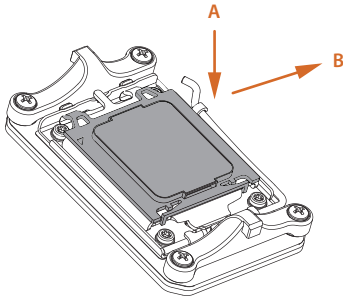

2

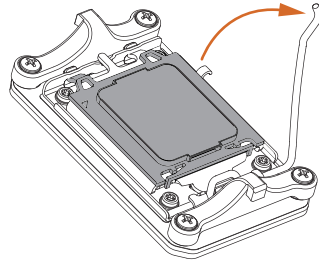

3

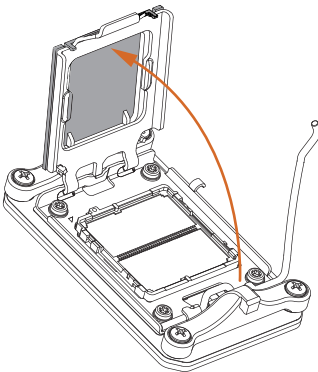

4

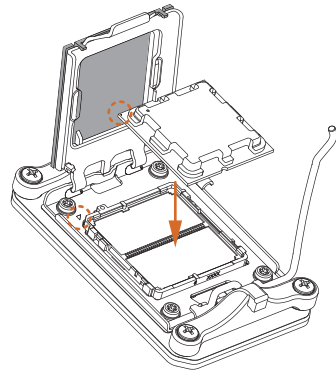

 Carefully place the CPU in as flat as possible. Do not drop it.

5

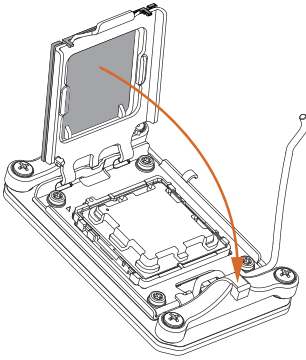

6

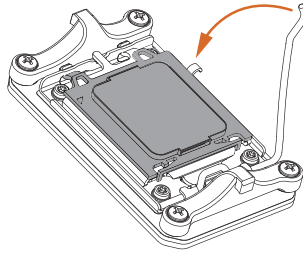

Make sure the CPU is aligned with the socket before locking it into place.

7

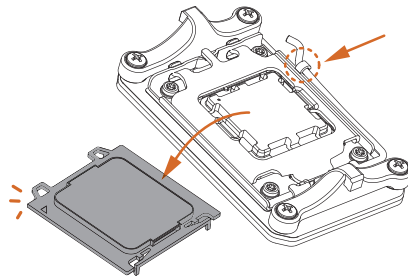

Make sure the black cover plate is always in place until it pops off when closing the socket lever.



Please save the cover if the processor is removed. The cover must be placed if you wish to return the motherboard for after service.

2.2 Installing the CPU Fan and Heatsink

After you install the CPU into this motherboard, it is necessary to install a larger heatsink and cooling fan to dissipate heat. You also need to spray thermal grease between the CPU and the heatsink to improve heat dissipation. Make sure that the CPU and the heatsink are securely fastened and in good contact with each other.



Please turn off the power or remove the power cord before changing a CPU or heatsink.

Installing the CPU Cooler

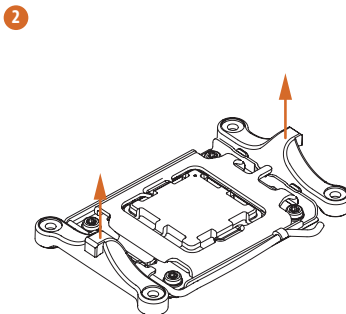
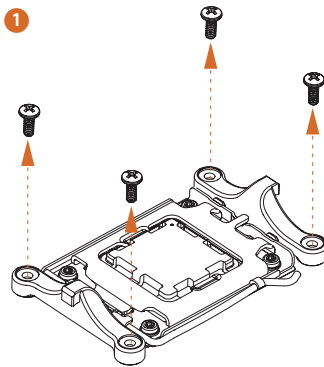

3

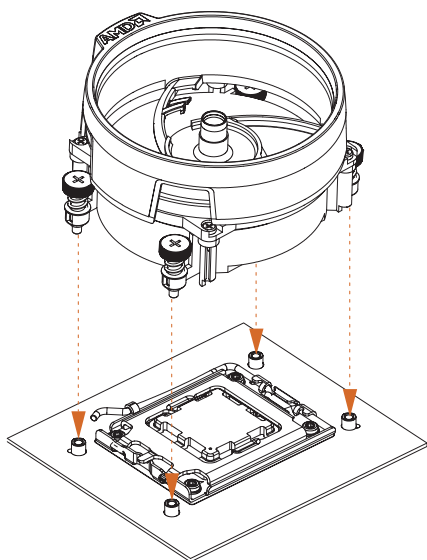

4

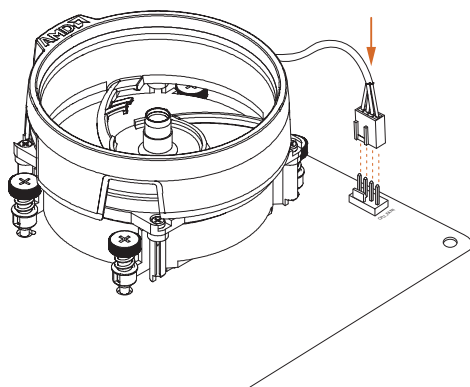

2.3 Installing Memory Modules (DIMM)

This motherboard provides four 288-pin DDR5 (Double Data Rate 5) DIMM slots, and supports Dual Channel Memory Technology.



1. For dual channel configuration, you always need to install identical (the same brand, speed, size and chip-type) DDR5 DIMM pairs.
2. It is unable to activate Dual Channel Memory Technology with only one or three memory module installed.
3. It is not allowed to install a DDR, DDR2, DDR3 or DDR4 memory module into a DDR5 slot; otherwise, this motherboard and DIMM may be damaged.
4. The DIMM only fits in one correct orientation. It will cause permanent damage to the motherboard and the DIMM if you force the DIMM into the slot at incorrect orientation.

Recommended Memory Configuration

1 DIMM

A1	A2	B1	B2
			V

2 DIMMs

A1	A2	B1	B2
	V		V

4 DIMMs

A1	A2	B1	B2
V	V	V	V

The first boot may take some time.

Please be patient and refer to the following table for booting time.

*It may vary by different setups.

Memory	1st boot after clear CMOS
2 x 16GB	90 sec
2 x 32GB	150 sec
4 x 16GB	170 sec
4 x 32GB	315 sec



The DIMM only fits in one correct orientation. It will cause permanent damage to the motherboard and the DIMM if you force the DIMM into the slot at incorrect orientation.

1

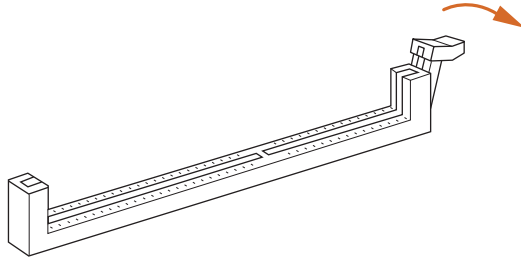

2

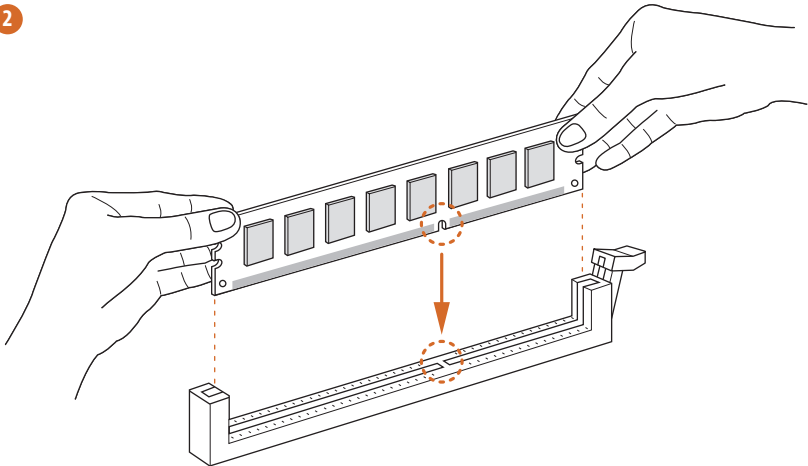

3

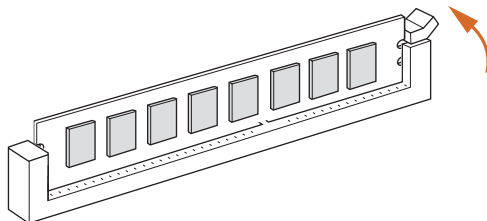

2.4 Expansion Slot (PCIe Slot)

There are 1 PCIe slot on the motherboard.



Before installing an expansion card, please make sure that the power supply is switched off or the power cord is unplugged. Please read the documentation of the expansion card and make necessary hardware settings for the card before you start the installation.

PCIe slot:

PCIe1 (PCIe 4.0 x16 slot) is used for PCIe x16 lane width graphics cards.

2.5 Jumpers Setup

The illustration shows how jumpers are setup. When the jumper cap is placed on the pins, the jumper is “Short”. If no jumper cap is placed on the pins, the jumper is “Open”.

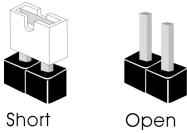

Clear CMOS Jumper
(CLR CMOS1)
(see p.5, No. 12)



2-pin Jumper

Short: Clear CMOS
Open: Default

CLR CMOS1 allows you to clear the data in CMOS. The data in CMOS includes system setup information such as system password, date, time, and system setup parameters. To clear and reset the system parameters to default setup, please turn off the computer and unplug the power cord, then use a jumper cap to short the pins on CLR CMOS1 for 3 seconds. Please remember to remove the jumper cap after clearing the CMOS. If you need to clear the CMOS when you just finish updating the BIOS, you must boot up the system first, and then shut it down before you do the clear-CMOS action.



If you clear the CMOS, the case open may be detected. Please adjust the BIOS option “Clear Status” to clear the record of previous chassis intrusion status.

2.6 Onboard Headers and Connectors



Onboard headers and connectors are NOT jumpers. Do NOT place jumper caps over these headers and connectors. Placing jumper caps over the headers and connectors will cause permanent damage to the motherboard.

System Panel Header
(9-pin PANEL1)
(see p.5, No.10)

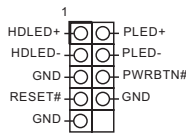

Connect the power button, reset button and system status indicator on the chassis to this header according to the pin assignments below. Note the positive and negative pins before connecting the cables.



PWRBTN (Power Button):

Connect to the power button on the chassis front panel. You may configure the way to turn off your system using the power button.

RESET (Reset Button):

Connect to the reset button on the chassis front panel. Press the reset button to restart the computer if the computer freezes and fails to perform a normal restart.

PLED (System Power LED):

Connect to the power status indicator on the chassis front panel. The LED is on when the system is operating. The LED keeps blinking when the system is in S1/S3 sleep state. The LED is off when the system is in S4 sleep state or powered off (S5).

HDLED (Hard Drive Activity LED):

Connect to the hard drive activity LED on the chassis front panel. The LED is on when the hard drive is reading or writing data.

The front panel design may differ by chassis. A front panel module mainly consists of power button, reset button, power LED, hard drive activity LED, speaker and etc. When connecting your chassis front panel module to this header, make sure the wire assignments and the pin assignments are matched correctly.

Serial ATA3 Connector
(SATA3_A1:
see p.5, No. 8)
(SATA3_A2:
see p.5, No. 9)



These two SATA3 connector supports SATA data cables for internal storage devices with up to 6.0 Gb/s data transfer rate.

USB 2.0 Header
(9-pin USB_5_6)
(see p.5, No. 7)

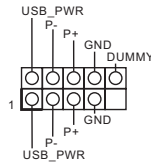

There is one header on this motherboard. This USB 2.0 header can support two ports.

Chassis Fan Connector
(4-pin CHA_FAN1)
(see p.5, No. 11)

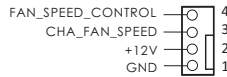

Please connect fan cable to the fan connector and match the black wire to the ground pin.

CPU Fan Connectors
(4-pin CPU_FAN1)
(see p.5, No. 2)

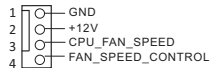

This motherboard provides a 4-Pin CPU fan (Quiet Fan) connector. If you plan to connect a 3-Pin CPU fan, please connect it to Pin 1-3.

ATX Power Connector
(24-pin ATXPWR1)
(see p.5, No. 6)

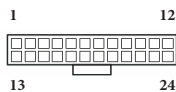

This motherboard provides a 24-pin ATX power connector. To use a 20-pin ATX power supply, please plug it along Pin 1 and Pin 13.

ATX 12V Power
Connector
(8-pin ATX12V1)
(see p.5, No. 1)

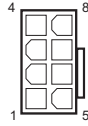

This motherboard provides a 8-pin ATX 12V power connectors. To use a 4-pin ATX power supply, please plug it along Pin 1 and Pin 5.

***Warning: Please make sure that the power cable connected is for the CPU and not the graphics card. Do not plug the PCIe power cable to this connector.**

Chassis Intrusion Header
(2-pin C1I)
(see p.5, No. 5)



This motherboard supports CASE OPEN detection feature that detects if the chassis cover has been removed. This feature requires a chassis with chassis intrusion detection design.

2.7 Smart Button

The motherboard has a smart button: BIOS Flashback Button, allowing users to flash the BIOS.

BIOS Flashback Button

(BIOS_FB1) (see p.9, No. 6)

BIOS Flashback Button allows users to flash the BIOS.

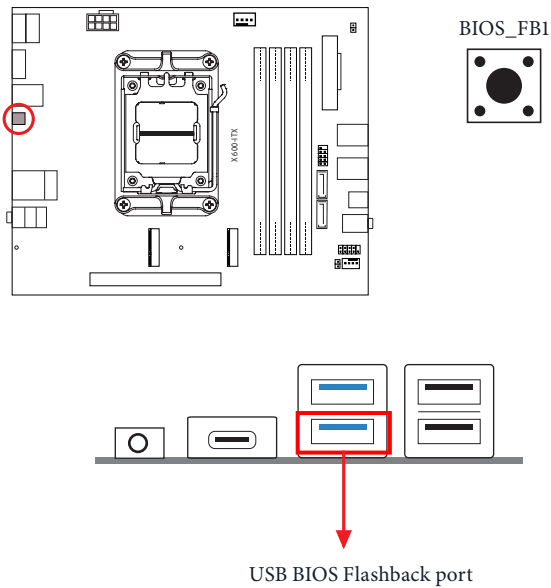

ASRock BIOS Flashback feature allows you to update BIOS without powering on the system, even without CPU.



Before using the BIOS Flashback function, please suspend BitLocker and any encryption or security relying on the TPM. Make sure that you have already stored and backup-ed the recovery key. If the recovery key is missing while encryption is active, the data will stay encrypted and the system will not boot into the operating system. It is recommended to disable fTPM before updating the BIOS. Otherwise an unpredictable failure may occur.

To use the USB BIOS Flashback function, Please follow the steps below.

1. Download the latest BIOS file from ASRock's website : <http://www.asrock.com>.
2. Copy the BIOS file to your USB flash drive. Please make sure the file system of your USB flash drive must be FAT32.
3. Extract BIOS file from the zip file.
4. Rename the file to "**creative.rom**" and save it to the root directory of X: USB flash drive.
5. Plug the 24 pin power connector to the motherboard. Then turn on the power supply's AC switch.

*There is no need to power on the system.

6. Then plug your USB drive to the USB BIOS Flashback port.
7. Press the BIOS Flashback Switch for about three seconds. Then the LED starts to blink.
8. Wait until the LED stops blinking, indicating that BIOS flashing has been completed.

*If the LED light turns solid green, this means that the BIOS Flashback is not operating properly. Please make sure that you plug the USB drive to the USB BIOS Flashback port.

**If the LED does not light up at all then please disconnect power from the system and remove/ disconnect the CMOS battery from the motherboard for several minutes. Reconnect power and battery and try again.

2.8 M.2 WiFi/BT Module Installation Guide

The M.2 is a small size and versatile card edge connector that aims to replace mPCIe and mSATA. The M.2 Socket (Key E) supports type 2230 WiFi/BT module.

Installing the WiFi/BT module

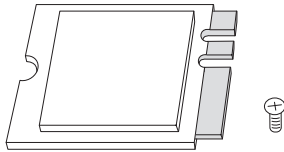

Step 1

Prepare a type 2230 WiFi/BT module and the screw.

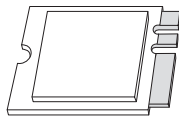

Step 2

Find the nut location to be used.

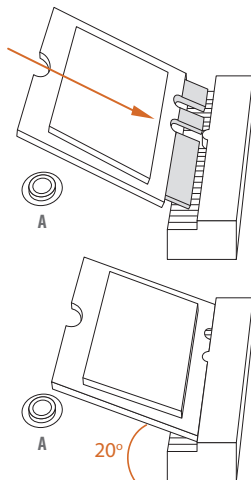
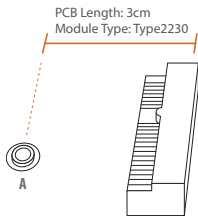

Step 3

Gently insert the WiFi/BT module into the M.2 slot. Please be aware that the module only fits in one orientation.

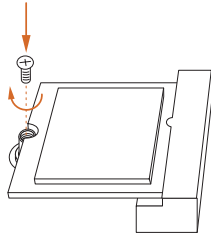

Step 4

Tighten the screw with a screwdriver to secure the module into place. Please do not overtighten the screw as this might damage the module.

2.9 M.2 SSD Module Installation Guide

The M.2 is a small size and versatile card edge connector that aims to replace mPCIe and mSATA. The Blazing M.2 Socket (M2_1, Key M) supports type 2280 PCIe Gen5x4 (128 Gb/s) mode. The Hyper M.2 Socket (M2_2, Key M) supports type 2280 PCIe Gen4x4 (64 Gb/s) mode.

Installing the M.2 SSD Module

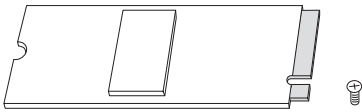

Step 1

Prepare a M.2 SSD Module and the screw.

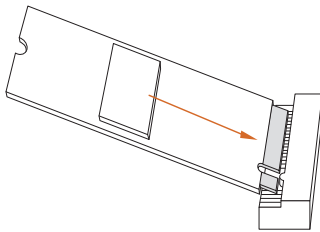

Step 2

Gently insert the M.2 SSD module into the M.2 slot. Please be aware that the M.2 SSD module only fits in one orientation.

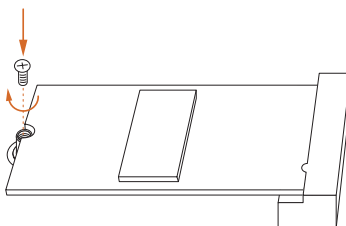
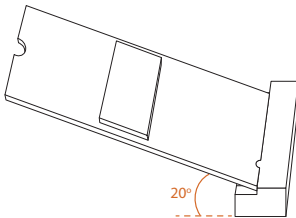

Step 3

Tighten the screw with a screwdriver to secure the module into place. Please do not overtighten the screw as this might damage the module.

M.2 SSD Module Support List

Vendor	Interface	P/N
ADATA	PCIe	ADATA ASX7000NPC-512GT-C (XPG SX7000) (NVMe)
ADATA	PCIe	ADATA ASX8000NPC-512GM-C (XPG ASX8000) (NVMe)
Apacer	PCIe	Apacer Z280 AP240GZ280-240G (NVMe)
Intel	PCIe	Intel Optane Memory 32GB (MEMPEK1W032GA)(NVMe)
Intel	PCIe	Intel Optane Memory 16GB (MEMPEK1W016GA)(NVMe)
INTEL	PCIe	INTEL 600P-SSDPEKKW256G7-256GB (NVMe)
INTEL	PCIe	INTEL 600P-SSDPEKKW128G7-128GB (NVMe)
INTEL	PCIe	INTEL 6000P-SSDPEKKF256G7-256GB (NVMe)
INTEL	PCIe	INTEL 6000P-SSDPEKKF512G7-512GB (NVMe)
Kingston	PCIe	Kingston SHPM2280P2/240G
PATRIOT	PCIe	PATRIOT Hellfire M2 (240G) (NVMe)
PLEXTOR	PCIe	PLEXTOR PX-256M8PeG (NVMe)
PLEXTOR	PCIe	PLEXTOR PX-256M8SeGN (NVMe)
Samsung	PCIe	Samsung XP941-512G (MZHPU512HCGL)
Samsung	PCIe	Samsung 950Pro-512G (NVMe)
Samsung	PCIe	Samsung 950Pro-256G (NVMe)
Samsung	PCIe	Samsung MZ-VLW1280 (PM961) (NVMe)
Samsung	PCIe	Samsung MZ-VPW1280 (SM961) (NVMe)
TOSHIBA	PCIe	TOSHIBA XG3-128G (NVMe)
TOSHIBA	PCIe	TOSHIBA OCZ RD400-256G (NVMe)
WD	PCIe	WD WDS512G1X0C-00ENX0 (NVMe)
WD	PCIe	WD WDS256G1X0C-00ENX0 (NVMe)

For the latest updates of M.2 SSD module support list, please visit our website for details.

Chapter 3 Auto Driver Installer

After you install the Windows OS and boot into the system, a notification will pop up to help you to install and update required drivers.

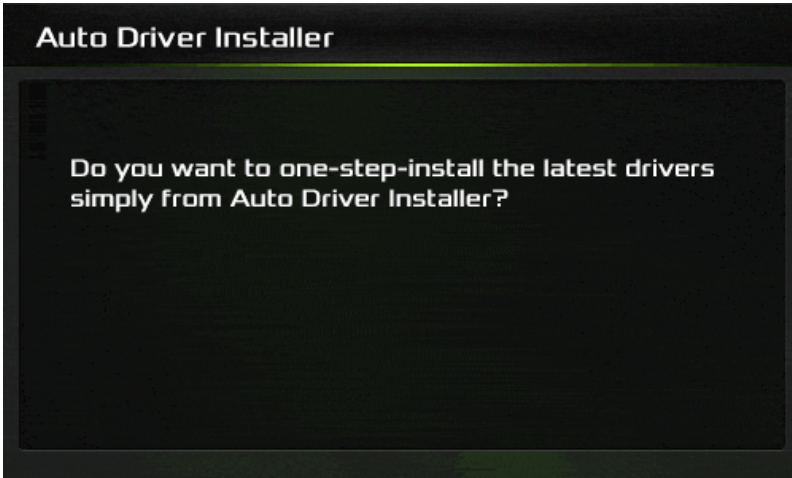

Chapter 4 UEFI SETUP UTILITY

4.1 Introduction

This section explains how to use the UEFI SETUP UTILITY to configure your system. You may run the UEFI SETUP UTILITY by pressing <F2> or right after you power on the computer, otherwise, the Power-On-Self-Test (POST) will continue with its test routines. If you wish to enter the UEFI SETUP UTILITY after POST, restart the system by pressing <Ctl> + <Alt> + <Delete>, or by pressing the reset button on the system chassis. You may also restart by turning the system off and then back on.



Because the UEFI software is constantly being updated, the following UEFI setup screens and descriptions are for reference purpose only, and they may not exactly match what you see on your screen.

4.1.1 UEFI Menu Bar

The top of the screen has a menu bar with the following selections:

Main	For setting system time/date information
OC Tweaker	For overclocking configurations
Advanced	For advanced system configurations
Tool	Useful tools
H/W Monitor	Displays current hardware status
Security	For security settings
Boot	For configuring boot settings and boot priority
Exit	Exit the current screen or the UEFI Setup Utility

4.1.2 Navigation Keys

Use <←> key or <→> key to choose among the selections on the menu bar, and use <↑> key or <↓> key to move the cursor up or down to select items, then press <Enter> to get into the sub screen. You can also use the mouse to click your required item.

Please check the following table for the descriptions of each navigation key.

Navigation Key(s)	Description
+ / -	To change option for the selected items
<Tab>	Switch to next function
<PGUP>	Go to the previous page
<PGDN>	Go to the next page
<HOME>	Go to the top of the screen
<END>	Go to the bottom of the screen
<F1>	To display the General Help Screen
<F7>	Discard changes and exit the SETUP UTILITY
<F9>	Load optimal default values for all the settings
<F10>	Save changes and exit the SETUP UTILITY
<F12>	Print screen
<ESC>	Jump to the Exit Screen or exit the current screen

4.2 Main Screen

When you enter the UEFI SETUP UTILITY, the Main screen will appear and display the system overview.



4.3 OC Tweaker Screen

In the OC Tweaker screen, you can set up overclocking features.



Because the UEFI software is constantly being updated, the following UEFI setup screens and descriptions are for reference purpose only, and they may not exactly match what you see on your screen.

Performance Preset

Use the ASRock Performance Preset.

Platform Thermal Throttle Limit (TjMax)

Allows the user to decrease the maximum allowed processor temperature (celsius).

DRAM Frequency

If [Auto] is selected, the motherboard will detect the memory module(s) inserted and assign the appropriate frequency automatically. Setting DRAM Frequency can adjust DRAM Timing.

DRAM Profile Configuration

Load EXPO/XMP settings to overclock the DDR5 memory and perform beyond standard specifications.

DRAM Timing Configuration

VDDIO Voltage (VDDIO_MEM_S3)

DDR5 bus signaling (PHY) is derived from VDDIO_MEM_S3.

DRAM VDD Voltage

Use this item to configure the VDD Voltage supported by PMIC at DRAM side.

DRAM VDDQ Voltage

Use this item to configure the VDDQ Voltage supported by PMIC at DRAM side.

DRAM VPP Voltage

Use this item to configure the VPP Voltage supported by PMIC at DRAM side.

Infinity Fabric Frequency and Dividers

AMD Overclocking Setup Set Infinity Fabric frequency (FCLK). Auto: FCLK = MCLK. Manual: FCLK must be less than or equal to MCLK for best performance in most cases. Latency penalties are incurred if FCLK and MCLK are mismatched, but sufficiently high MCLK can negate or overcome this penalty.

UCLK DIV1 MODE

Use this item to set UCLK DIV1 MODE.

SoC/Uncore OC Voltage(VDD_SOC)

Allows you to specify the SoC/Uncore voltage (VDD_SOC) to support memory and Infinity Fabric overclocking. VDD_SOC also determines the GPU voltage on processors with integrated graphics.

VDD Misc Voltage

Allows you to configure the PCIe, DP Phy, PLL, ClkGen, and Pmux Supply.

VDDG CCD Voltage

VDDG CCD represents voltage for the data portion of the Infinity Fabric. It is derived from the CPU SoC/Uncore Voltage (VDD_SOC). VDDG can approach but not exceed VDD_SOC.

VDDG IOD Voltage

VDDG IOD represents voltage for the data portion of the Infinity Fabric. It is derived from the CPU SoC/Uncore Voltage (VDD_SOC). VDDG can approach but not exceed VDD_SOC.

VDDP Voltage

VDDP is a voltage for the DDR bus signaling (PHY), and it is derived from your DRAM Voltage (VDDIO_Mem). As a result, VDDP voltage can approach but not exceed your DRAM Voltage.

Overclock mode (Bus Speed)

Use this item to set overclock mode.

External Voltage Settings

Press [Enter] to configure the voltage options.

Save User Default

Type a profile name and press enter to save your settings as user default.

Load User Default

Load previously saved user defaults.

Save User UEFI Setup Profile to Disk

Save current UEFI settings as an user default profile to disk.

Load User UEFI Setup Profile to Disk

Load previously saved user defaults from the disk.

4.4 Advanced Screen

In this section, you may set the configurations for the following items: CPU Configuration, PCI Configuration, Onboard Devices Configuration, Storage Configuration, ACPI Configuration, USB Configuration, Trusted Computing, AMD CBS, AMD PBS and AMD Overclocking.



Setting wrong values in this section may cause the system to malfunction.

UEFI Configuration

Active Page on Entry

Allows you to select the default page when entering the UEFI setup utility.

Configuration options: [Main] [OC Tweaker] [Advanced] [Tool] [H/W Monitor] [Security] [Boot] [Exit]

Full HD UEFI

When [Auto] is selected, the resolution will be set to 1920 x 1080 if the monitor supports Full HD resolution. If the monitor does not support Full HD resolution, then the resolution will be set to 1024 x 768. When [Disable] is selected, the resolution will be set to 1024 x 768 directly.

4.4.1 CPU Configuration



PSS Support

Use this to enable or disable the generation of ACPI_PPC, _PSS, and _PCT objects.

NX Mode

Use this to enable or disable NX mode.

SVM Mode

When this is set to [Enabled], a VMM (Virtual Machine Architecture) can utilize the additional hardware capabilities provided by AMD-V. The default value is [Enabled]. Configuration options: [Enabled] and [Disabled].

SMT Mode

This item can be used to disable symmetric multithreading. To re-enable SMT, a power cycle is needed after selecting [Auto].

Warning: S3 is not supported on systems where SMT is disabled.

AMD fTPM Switch

Use this to enable or disable AMD CPU fTPM.

Configuration options: [AMD CPU fTPM] [Route to SPI TPM] [Disabled]

4.4.2 PCI Configuration

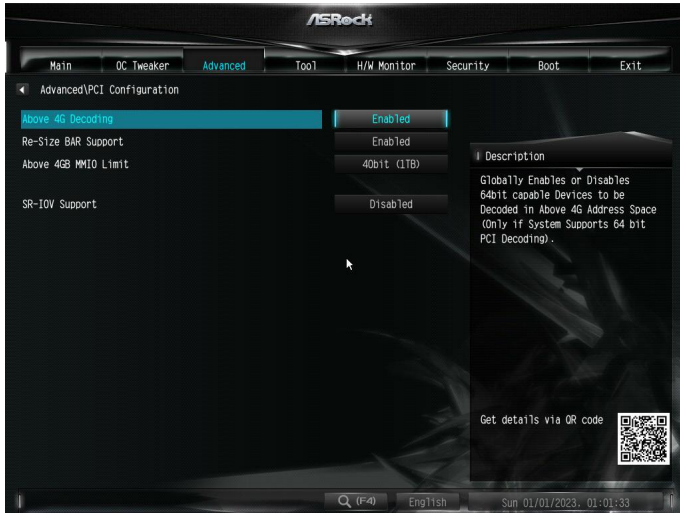

Above 4G Decoding

Globally enables or disables 64-bit capable devices to be decoded in Above 4G Address Space (only if the system supports 64-bit PCI Decoding).

Re-Size BAR Support

If system has Resizable BAR capable PCIe Devices, this option enables or disables Resizable BAR Support.

Above 4GB MMIO Limit

Allows you to select Above 4GB MMIO Limit to 38~43 bits limit. This option works only when "Above 4G decoding" is enabled.

Configuration options: [40bit (1TB)] [41bit (2TB)] [42bit (4TB)] [43bit (8TB)]

SR-IOV Support

If system has SR-IOV capable PCIe Devices, this option enables or disables Single Root IO Virtualization Support.

4.4.3 Onboard Devices Configuration



Display Priority

Select the display priority.

Onboard HD Audio

Enable/disable onboard HD audio.

Onboard LAN

Enable or disable the onboard network interface controller

WIFI Card

Enable/disable the WIFI Card.

4.4.4 Storage Configuration

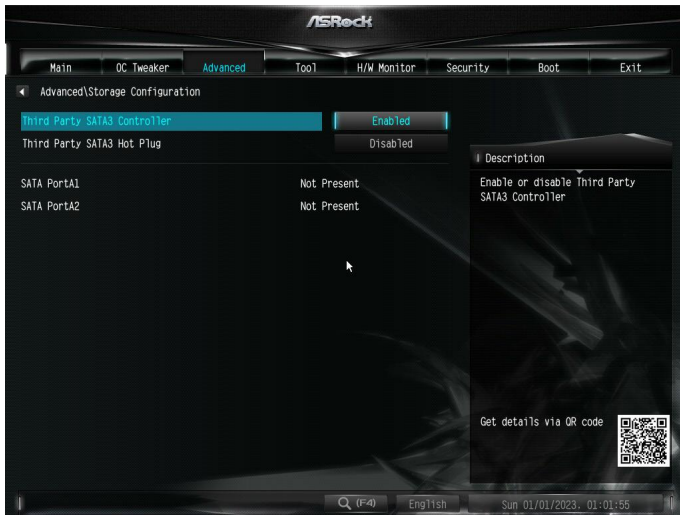

Third Party SATA 3 Controller

Enable or disable the third party SATA3 controller.

Third Party SATA3 Hot Plug

Enable or disable the third party SATA3 controller.

4.4.5 ACPI Configuration



Suspend to RAM

It is recommended to select auto for ACPI S3 power saving.

Configuration options: [Disabled] [Auto]

Restore on AC/Power Loss

Allows you to select the power state after a power failure.

[Power Off] Select this item and the power will remain off when the power recovers.

[Power On] Select this item and the system will start to boot up when the power recovers.

Configuration options: [Power On] [Power Off]

Deep Sleep

Allows you to configure deep sleep mode for power saving when the computer is shut down. We recommend disabling Deep Sleep for better system compatibility and stability.

Configuration options: [Disabled] [Enabled in S5] [Enabled in S4 & S5]

USB Power delivery in Soft Off state (S5)

If this option is enabled, the USB port will provide power to your devices even when the system is in Power State S5.

PCIE Devices Power On

[Enabled] Select this item to allow the system to be waked up by a PCIE device and enable wake on LAN.

[Disabled] Select this item to disallow the system to be waked up by a PCIE device and disable wake on LAN.

RTC Alarm Power On

[Enabled]

Select this item to allow the system to be waked up by the real time clock alarm.

[Disabled]

Select this item to disallow the system to be waked up by the real time clock alarm.

[By OS]

Select this item to let it be handled by your operating system.

4.6.6 USB Configuration

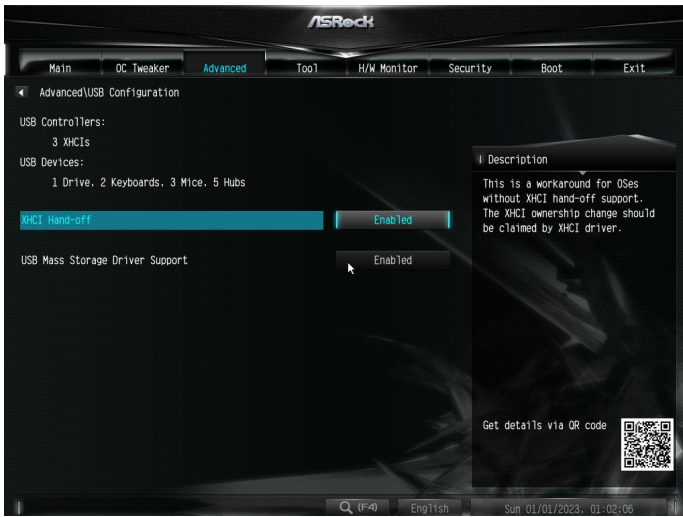

XHCI Hand-off

This is a workaround for OSes without XHCI hand-off support. The XHCI ownership change should be claimed by XHCI driver.

4.4.7 Trusted Computing

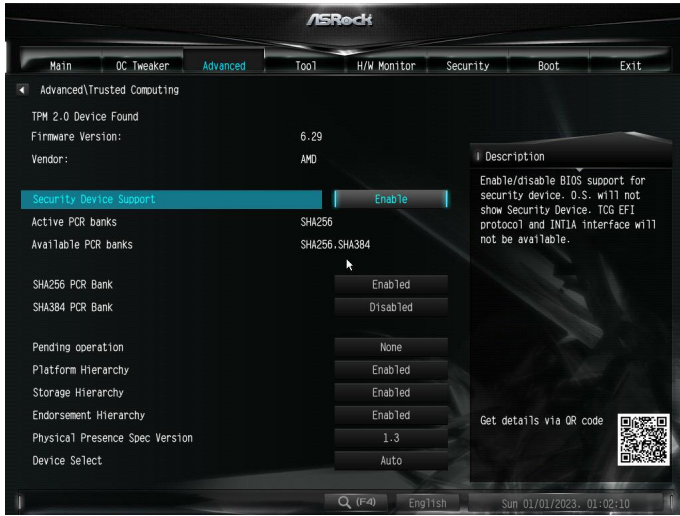

NOTE: Options vary depending on the version of your connected TPM module.

Security Device Support

Use this item to enable or disable BIOS support for security device. O.S. will not show Security Device. TCG EFI protocol and INT1A interface will not be available.

SHA-1 PCR Bank

Use this item to enable or disable SHA-1 PCR Bank.

SHA256 PCR Bank

Use this item to enable or disable SHA256 PCR Bank.

Pending Operation

Schedule an Operation for the Security Device.

NOTE: Your computer will reboot during restart in order to change State of the Device.

Platform Hierarchy

Use this item to enable or disable Platform Hierarchy.

Storage Hierarchy

Use this item to enable or disable Storage Hierarchy.

Endorsement Hierarchy

Use this item to enable or disable Endorsement Hierarchy.

TPM2.0 UEFI Spec Version

Use this item to select the TCG2 spec. version supported.

The optional settings: [TCG_1_2]; [TCG_2].

[TCG_1_2]: compatible mode for Win8/Win10.

[TCG_2]: for TCG2 newer spec. compatible mode for Win10

Physical Presence Spec version

Select this item to tell OS to support PPI spec version 1.2 or 1.3. Please note that some HCK tests might not support version 1.3.

Device Select

Use this item to select the TPM device to be supported. TPM 1.2 will restrict support to TPM 1.2 devices. TPM 2.0 will restrict support to TPM 2.0 devices. Auto will support both with the default set to TPM 2.0 devices. If TPM 2.0 devices are not found, TPM 1.2 devices will be enumerated.

4.6.8 AMD CBS



The AMD CBS menu accesses AMD specific features.

4.6.9 AMD PBS

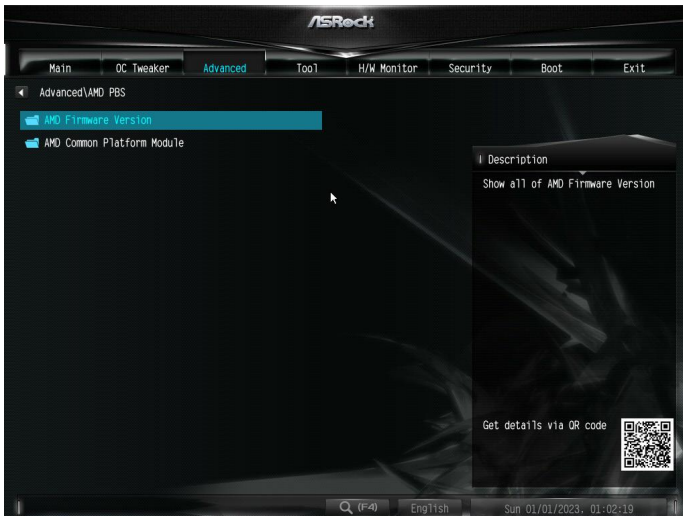

The AMD PBS menu accesses AMD specific features.

3.4.10 AMD Overclocking

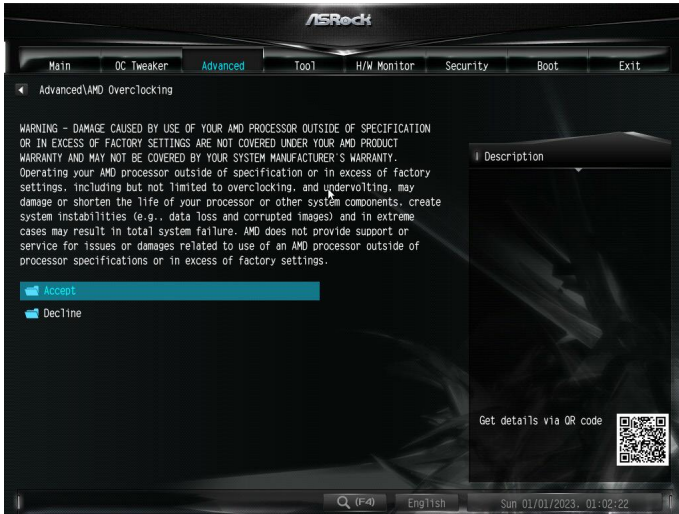

The AMD Overclocking menu accesses options for configuring CPU frequency and voltage.

4.5 Tools

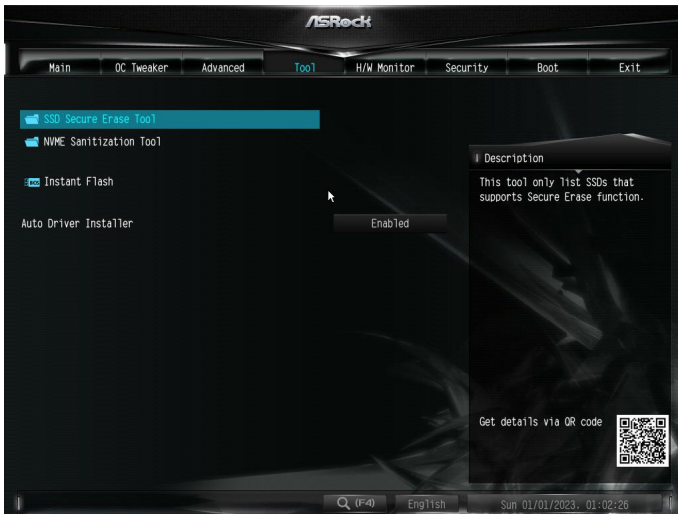

SSD Secure Erase Tool

Use this tool to securely erase SSD. This tool only lists the SSDs that support the Secure Erase function.

NVME Sanitization Tool

After you Sanitize SSD, all user data will be permanently destroyed on the SSD and cannot be recovered.

Instant Flash

Save UEFI files in your USB storage device and run Instant Flash to update your UEFI.

4.6 Hardware Health Event Monitoring Screen

This section allows you to monitor the status of the hardware on your system, including the parameters of the CPU temperature, motherboard temperature, fan speed and voltage.



CPU Fan 1 Setting

Select a fan mode for CPU Fan 1, or choose Customize to set 5 CPU temperatures and assign a respective fan speed for each temperature.

Fan Step Up

Set the value of CPU Fan 1 Step Up.

Fan Step Down

Set the value of CPU Fan 1 Step Down.

Chassis Fan 1 Setting

Select a fan mode for Chassis Fan 1, or choose Customize to set 5 CPU temperatures and assign a respective fan speed for each temperature.

Chassis Fan 1 Temp Source

Select a fan temperature source for Chassis Fan 1.

Fan Step Up

Set the value of Chassis Fan 1 Step Up.

Fan Step Down

Set the value of Chassis Fan 1 Step Down.

Fan-Tastic

Allows you to select a fan mode for Fan, or choose [Customize] to set 5 CPU temperatures and assign a respective fan speed for each temperature.

FanTuning

When selected, the BIOS will proceed to detect the lowest fan speeds for fans connected to the motherboard. This process will take a few minutes to complete.

Note: Please note CAM settings applied within the OS will overwrite settings made within the BIOS.

Case Open Feature

Enable or disable Case Open Feature to detect whether the chassis cover has been removed.

4.7 Security Screen

In this section you may set or change the supervisor/user password for the system. You may also clear the user password.



Supervisor Password

Set or change the password for the administrator account. Only the administrator has authority to change the settings in the UEFI Setup Utility. Leave it blank and press enter to remove the password.

User Password

Set or change the password for the user account. Users are unable to change the settings in the UEFI Setup Utility. Leave it blank and press enter to remove the password.

Secure Boot

Enable to support Secure Boot.

4.8 Boot Screen

This section displays the available devices on your system for you to configure the boot settings and the boot priority.



CSM

Enable to launch the Compatibility Support Module. Please do not disable unless you're running a WHCK test.

Launch PXE OpROM Policy

Select UEFI only to run those that support UEFI option ROM only. Select Legacy only to run those that support legacy option ROM only. Select Do not launch to not execute both legacy and UEFI option ROM.

Launch Storage OpROM Policy

Select UEFI only to run those that support UEFI option ROM only. Select Legacy only to run those that support legacy option ROM only. Select Do not launch to not execute both legacy and UEFI option ROM.

Setup Prompt Timeout

Configure the number of seconds to wait for the setup hot key.

Bootup Num-Lock

Select whether Num Lock should be turned on or off when the system boots up.

Full Screen Logo

Enable to display the boot logo or disable to show normal POST messages.

Fast Boot

Fast Boot minimizes your computer's boot time. In fast mode you may not boot from an USB storage device.

4.9 Exit Screen

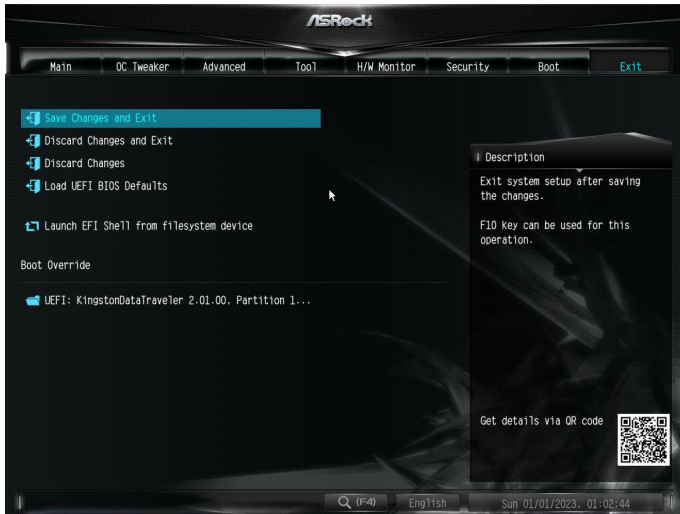

Save Changes and Exit

When you select this option the following message, “Save configuration changes and exit setup?” will pop out. Select [OK] to save changes and exit the UEFI SETUP UTILITY.

Discard Changes and Exit

When you select this option the following message, “Discard changes and exit setup?” will pop out. Select [OK] to exit the UEFI SETUP UTILITY without saving any changes.

Discard Changes

When you select this option the following message, “Discard changes?” will pop out. Select [OK] to discard all changes.

Load UEFI Defaults

Load UEFI default values for all options. The F9 key can be used for this operation.

Launch EFI Shell from filesystem device

Copy shellx64.efi to the root directory to launch EFI Shell.

DECLARATION OF CONFORMITY

Per FCC Part 2 Section 2.1077(a)



Product Name : Motherboard

Model Number : X600-ITX

Conforms to the following specifications:

FCC Part 15, Subpart B, Unintentional Radiators

Supplementary Information:

This device complies with part 15 of the FCC Rules. Operation is subject to the following two conditions: (1) This device may not cause harmful interference, and (2) this device must accept any interference received, including interference that may cause undesired operation.

EU Declaration of Conformity

For the following equipment:

Motherboard

(Product Name)

X600-ITX

(Model Designation / Trade Name)

EMC Directive – 2014/30/EU

EN 55032: 2015 / A11: 2020, EN 55035: 2017 / A11: 2020
EN IEC 61000-3-2: 2019, EN 61000-3-3: 2013

RoHS Directive - 2011/65/EU

2015/863/EU, EN IEC 63000:2018



(EU conformity marking)