

WORK 0102

OFFICE OF WASTE REDUCTION  
N. C. DEPT. OF EHNH  
P. O. BOX 27687  
RALEIGH, N. C. 27611-7687

P 02346  
29418 PDF



PETE



HDPE



V

# Report on State Laws



LDPE

## Plastic Container Material Coding 1990



PP



PS



OTHER



The Society of the Plastics Industry, Inc.

## **Members of The Plastic Bottle Institute**

Allied-Signal Corporation  
American National Can Company  
Beatrice/Hunt-Wesson, Inc.  
The BF Goodrich Company  
B P Chemicals, Inc.  
Continental Can Company, Inc.  
Dow Chemical USA  
Exxon Chemical Americas  
Georgia Gulf Corporation  
Mobil Chemical Company  
Murphy-Phoenix Company  
Occidental Chemical Corporation  
Owens-Brockway, Inc.  
Phillips 66 Company  
PMS Consolidated  
Progressive Plastics, Inc.  
Quantum Chemical Corporation  
Rohm and Haas Company  
Setco, Inc.  
Solvay Polymers, Inc.  
Sunbeam Plastics Corporation  
Trans Container Corporation  
Union Carbide Corporation

1/2/91

The Plastic Bottle Institute

a division of

The Society of the Plastics Industry, Inc.

## REPORT ON STATE LAWS

### Plastic Container Material Coding

To the best of our knowledge, the information contained herein is accurate. However, The Society of the Plastics Industry, Inc. assumes no liability whatsoever for the accuracy or completeness of the information contained herein. Also, it must be recognized that sound legal advice requires a thorough understanding of the factual context of any issue or problem that arises. Only then can a reasoned application of law be made to the specific facts upon consideration of the practical problems presented and the legal alternatives available. No report, by itself, can provide sound legal advice, least of all, one which is intended only to summarize legal requirements imposed by a wide variety of jurisdictions. Providing legal advice is beyond the scope and purpose of this report.

November 1990

The Plastic Bottle Institute, a Division of  
The Society of the Plastics Industry, Inc.  
1275 K Street, N.W. Washington, D.C. 20005

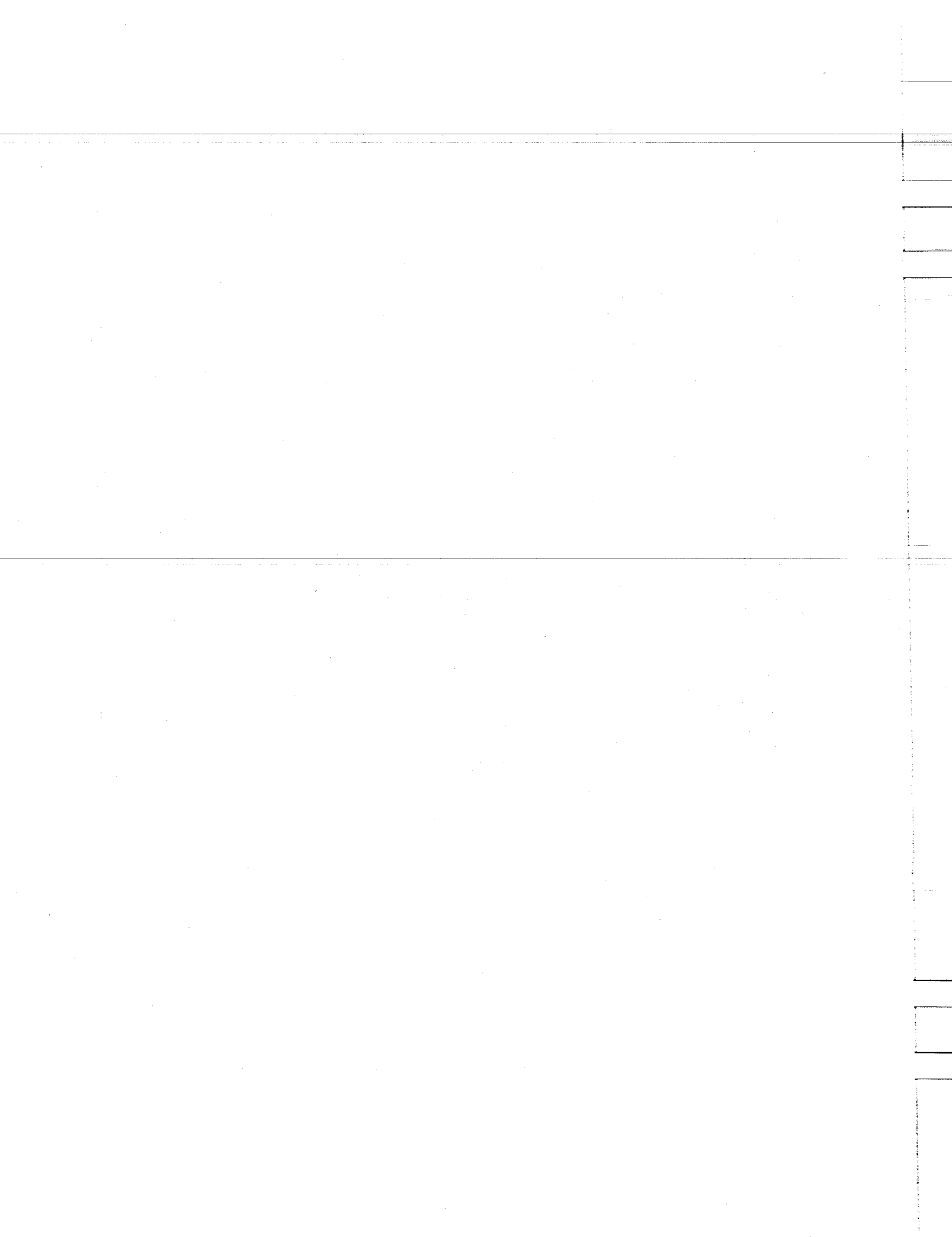



# TABLE OF CONTENTS

PREFACE .....	v
INTRODUCTION .....	vii
STATE LAW OVERVIEW .....	1
Plastic Bottle Coding .....	1
Rigid Plastic Container Coding .....	4
PLASTIC CONTAINER CODING SUMMARIES .....	7
SPI Voluntary Guidelines .....	9
<b>GEOGRAPHIC REGIONS: Eastern, Midwestern, New England, Western .....</b>	<b>31</b>
<b>New England Region .....</b>	<b>33</b>
Connecticut .....	35
Maine .....	41
Massachusetts .....	47
*New Hampshire .....	51
*New York .....	55
Rhode Island .....	57
<b>Eastern Region .....</b>	<b>63</b>
Florida .....	65
Georgia .....	75
Louisiana .....	81
New Jersey .....	85
North Carolina .....	91
Tennessee .....	95
Virginia .....	101
<b>Mid Western Region .....</b>	<b>105</b>
Illinois .....	107
Indiana .....	111
Iowa .....	115
Michigan .....	119
Minnesota .....	125
Missouri .....	129
North Dakota .....	133
Ohio .....	137
Wisconsin .....	147
<b>Western Region .....</b>	<b>165</b>
Alaska .....	167
Arizona .....	173
California .....	177
Colorado .....	185
Hawaii .....	193
Oklahoma .....	197
Texas .....	203

**States preceded by an \* control the use of recycling emblems on plastic containers but do not require resin identification markings. These states are not included in the STATE LAW OVERVIEW.**

\*The Society of the Plastics Industry, Inc.

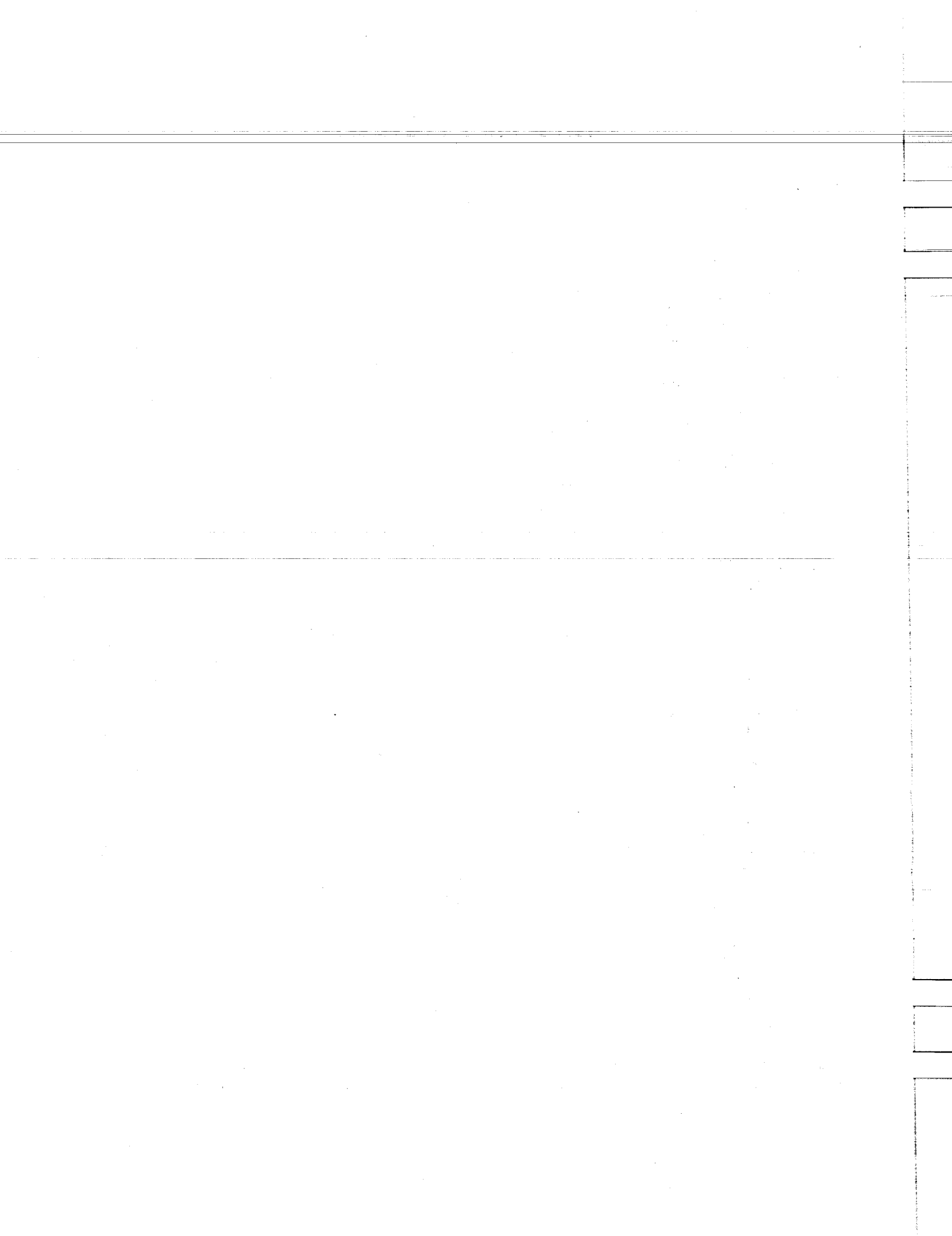

## PREFACE

This report was created by the Plastic Bottle Institute (PBI), a Division of The Society of the Plastics Industry, Inc. (SPI), as a service to its members and to the industry as a whole. The 1990 edition has been updated to include the laws enacted this past year in Alaska, Arizona, Georgia, Hawaii, Rhode Island, Tennessee, and Virginia. New developments in Florida and Wisconsin are also included. The laws included in the book, and the accompanying explanations, cover all plastic containers. We trust that you will find the information useful for determining how best to comply with the legally mandated container material coding requirements of the states in which you and your customers do business.

In July, 1988, SPI developed the voluntary coding system that has been the basis for most of this subsequent state legislation. Although SPI's Council for Solid Waste Solutions provided many state legislatures with advice on appropriate wording of the laws, some were written to respond to advice from other sources as well. These may include provisions which appear to require variations from the SPI voluntary system and from the requirements of other states. Some laws are subject to varying interpretations.

So that container manufacturers and their customers may have the information necessary to resolve questions of interpretation, this manual includes copies of actual statutory documents covering both laws and regulations, in addition to a summary description of their provisions. Also listed is the name and address of the appropriate agency to contact for more information in each state. Where the intent of a provision is not clear, the interpretation must be made by the agency charged with enforcing the law, rather than by PBI.

PBI is aware of the problems caused by variations among the state laws. It is the intention of PBI, in cooperation with the Council for Solid Waste Solutions and other interested supporters, to continue to seek amendments to eliminate the obstacles to recycling created by different coding requirements for different states. To further our interest in uniformity among the state coding requirements, PBI has developed a model coding statute. The model language has been closely followed by the states that have most recently enacted coding legislation.

It has also been used as a guide by at least one state to interpret its statutory provisions to achieve maximum national uniformity.

---

John C. Malloy  
Staff Director  
Plastic Bottle Institute  
1275 K Street, N.W., #400  
Washington, D.C. 20005

## INTRODUCTION

Plastic bottle and rigid plastic container coding has been the subject of legislation in many jurisdictions. For the most part, the states that have enacted legislation have adopted the voluntary resin identification codes developed by the Plastic Bottle Institute of The Society of the Plastics Industry, Inc. (SPI) to identify the six thermoplastic resins which are used in greatest volume to manufacture bottles and containers. This manual has been designed to assist manufacturers and users of plastic containers in their efforts to comply with applicable state laws by highlighting the requirements in state legislation which depart from the widely accepted adherence of the states to the voluntary guidelines developed by SPI.

The voluntary guidelines are comprehensive and provide an effective method by which plastic container manufacturers and users may label plastic products to facilitate recycling. Technical Reports published by the Plastic Bottle Institute (PBI-24) and the Rigid Plastic Container Division (RPCD-13) provide recommendations (1) on the use of coding symbols to identify material resins, (2) mold modification methods for manufacturers, and (3) other general information to be used by the industry to appropriately code plastic products. Copies of these documents are included as Attachments to the SPI Voluntary Guidelines Summary in this report.

The coding system is designed to facilitate one step in the recycling process, i.e., sorting. The sole purpose of the code is to identify the basic material resin composition of plastic containers into the smallest number of categories that will be useful to recyclers. While technologies do exist for recycling mixed resins, higher value applications for recycled resins are possible if each major resin type is separately recycled. By coding containers, recyclers will be able to easily identify and, thus, separate particular plastic resins one from another. The code does not preclude further segregation by recyclers based upon other characteristics, e.g., color, that might further enhance the value of recycled materials.

It is apparent from this Report that the voluntary coding system has received the endorsement of many state legislators. However, as various states have adopted the voluntary system as their own, minor variations have emerged that make it difficult to determine how best to code containers for national distribution. Indeed, the problem is not limited to traditional container manufacturers that sell wholesale to major packagers of consumer commodities. At least one state, viz., Wisconsin, has interpreted its law as being applicable to single service

drinking cups when sold to a restaurant or similar enterprise that will fill the container prior to a sale to the final consumer. The the definition of a rigid plastic container in several other states is also broad enough to include drinking cups.

A year ago at this time, a number of states were considering outright prohibitions on the use of SPI's resin identification symbol. The concern in these states was that the resin identification code would be interpreted as a representation that the container was being recycled. Now that the codes are in widespread use, it is apparent that this concern was not warranted. This appears to have abated when the proposed prohibition was voted down by Connecticut's legislature in October 1989.

This manual sets out the varying state coding laws with particular emphasis on variations from the voluntary system. In this regard, there are several minor inconsistencies that occur with enough frequency to bear comment. They relate to the coding of containers that (1) are made with a multilayer material or (2) have a label and base cup made of an incompatibly different resin than the container itself and (3) certain repeated-use containers such as insulated picnic chests and jugs. These common variations are summarized below.

1. **MULTILAYER MATERIALS.** Virtually all states agree with the voluntary coding system that "7-OTHER" applies to resins not designated in categories one through six. Furthermore, most define that "7-OTHER" is the code to use for a multilayer material. Two states define "7-OTHER" as meaning only multilayer and, no doubt through oversight, never specify any code for resins other than those identified by 1 through 6. The voluntary system is consistent with the predominant state requirement in recommending "7-OTHER" for multilayer. The significant difference, however, is that the voluntary system adopts a functional approach to each of the resin codes and provides that a multilayer bottle which is predominantly composed of a single resin may be coded on the basis of the predominant resin content as long as the other resin(s) in the container are compatible in recycling systems for the predominant resin.

The omission of an exception to the "7-OTHER" classification for multilayer containers that are functionally recyclable as the predominant resin is inconsistent with the objectives to be gained by coding, *viz.*, maximizing the value of recycled materials. Accordingly, the voluntary coding system's recommendation on this point does not contravene the intent of most of the state legislation even though it does appear to contravene the express statutory language used by many states.

Manufacturers of multilayer containers that can be recycled as the predominant (or only) resin may wish to seek legal counsel as to their options or seek rulings regarding their specific material combinations on a state-by-state basis.

2. **LABELS AND BASE CUPS.** The voluntary system provides that bottles or containers with labels or base cups or other components of a secondary material may carry the code of the basic material of which the container is constructed as long as the secondary materials are all compatible in recycling systems for the basic material. In these situations, the code of the basic material resin could be imprinted on either the bottle or the other component. Thus, for example, a plastic bottle whose primary, basic material is polyethylene terephthalate might have a base cup composed of high density polyethylene that would be imprinted with the "1-PETE" code.

Although it appears that the intent of most states was to adopt the position of the voluntary guidelines, the actual wording contained in several of the statutes is ambiguous. They typically provide that plastic bottles or containers with base cups or labels of different materials should be coded by their basic material. The ambiguity is that it is not clear whether "their" refers to the container or to the secondary component. However, since none of the states purport to prohibit the sale of containers with plastic labels that are not identified as to resin type, it seems reasonable to interpret "their" as referring to the container and the appropriate code as the code for the resin that makes up the structure of the container.

From the standpoint of maximizing the value of recycled materials, however, the above interpretation of what the states allow contains a serious flaw. The flaw is related to the problem discussed above in the context of multilayer materials, *i.e.*, the absence of a functional recyclability test. In this case, however, rather than arbitrarily exclude material that could easily be recycled as a specific resin type, many of the state coding laws appear to mandate inclusion under a basic material type of base cup and label material even though they may be detrimental to the recycling of the basic container resin. The result of including materials that are incompatible with recycling the basic resin are much more serious than simply excluding material from its highest possible recycling use; it has the potential to disrupt the high value use of large volumes of recycled materials. Companies that use containers with base cups or labels that are incompatible with recycling systems for the base resin are strongly urged to seek rulings from the states that would allow such containers to be coded "7-OTHER."

Many of the more recently enacted laws, patterned after PBI's model language, are silent on the treatment of labels and

base cups. Subject to any guidance put out by these states, we would not generally interpret such silence to prohibit the coding of a polyethylene terephthalate soft-drink bottle as "1-PETE."

3. **REPEATED-USE CONTAINERS.** Most of the state coding statutes distinguish between plastic bottles and other rigid plastic containers because the minimum size plastic bottle that requires coding is typically larger than the minimum size which requires coding for other rigid plastic containers. Most states are specific about defining the coding requirement for rigid plastic containers other than bottles as being applicable only to containers intended for single service use. As a result of what appears to be an oversight, many states do not include the single service limitation in their definition of a plastic bottle. Companies should seek appropriate assurances from the authorities in these states before concluding that the coding requirement does not apply to repeated-use bottles, e.g., insulated beverage containers.

\* \* \* \* \*

The statutes passed in Connecticut, Minnesota and Wisconsin delegate most of the details of the coding requirements to regulatory agencies. New Hampshire and New York do not impose resin coding requirements, per se; their statutes are included in this manual because the statutes do regulate certain markings on containers.

The careful reader will notice any number of interesting variations among the enforcement provisions of the coding laws. Some state statutes give rise to violations when a container is manufactured (whether or not within the state) with the intent that the (unmarked) container be sold in the state. Many, but not all, also make it a violation to sell the unmarked container within the state. Other states penalize the sale within the state of an unmarked bottle but do not penalize the distant manufacturer for having made the bottle. A number of states lack any specific enforcement power regarding uncoded plastic containers and the persons that sell them. The absence of a civil penalty provision might slow, but would probably not deter, a state official determined to get tough on this issue. Enforcement officials could seek to seize the non-compliant product or initiate an action to enjoin future violations. As a practical matter, however, it would probably be as effective and



substantially less costly to use negative publicity to achieve compliance. If non-compliance were a serious problem, the most likely solution might well be for the state legislature to amend the statute to provide for a specific, easily imposed civil penalty.

John B. Dubeck, Esq.

KELLER AND HECKMAN  
1150 17th Street, N.W.  
Suite 1000  
Washington, D.C. 20036

(202) 956-5600

November 1990

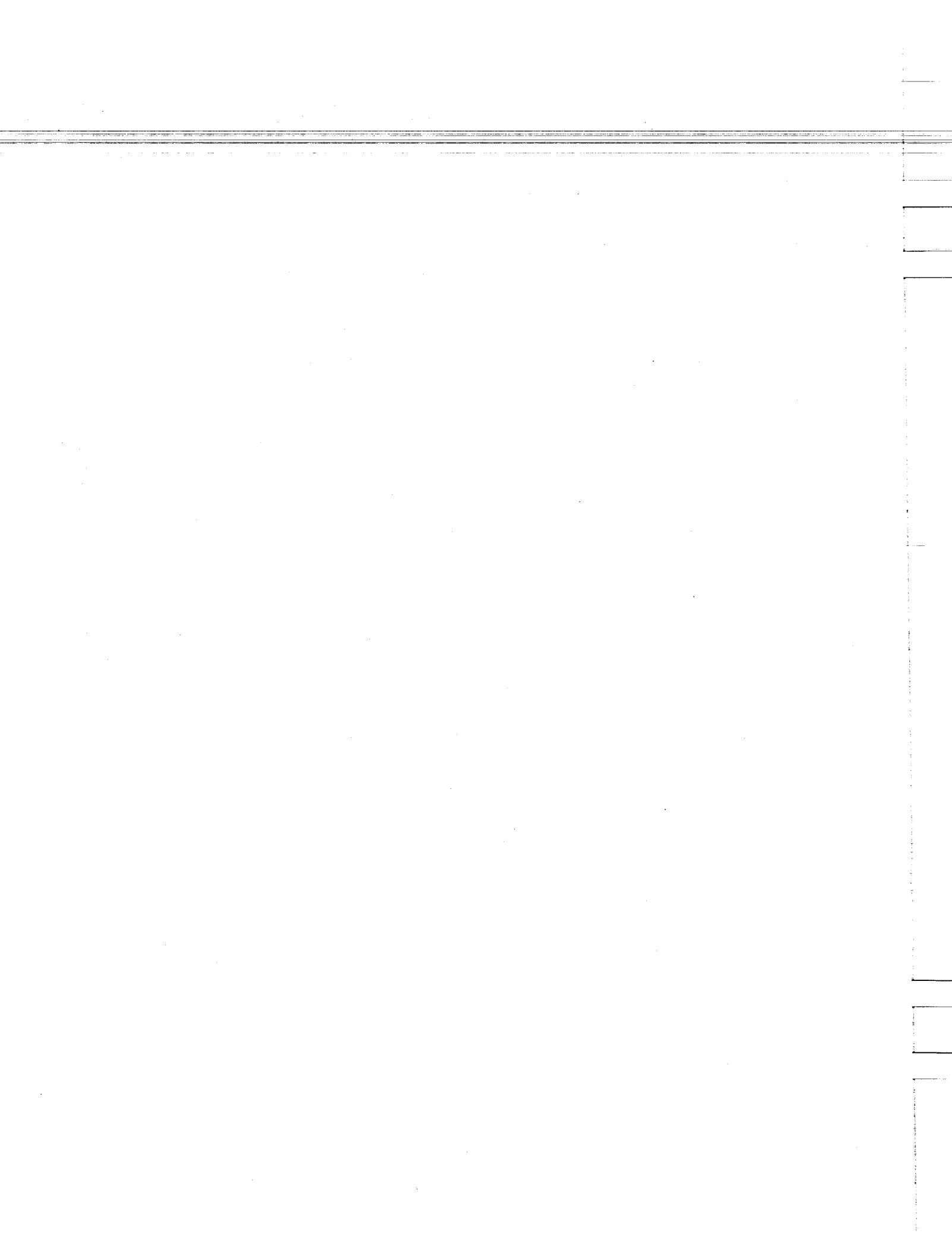

**STATE LAW OVERVIEW**  
for  
**Plastic Bottle Coding**  
(See separate list for Rigid Plastic Containers)

Jurisdiction	Compliance Date	Minimum and Maximum Size	Recommended/Required Markings	Penalties
Nationwide/ SPI Voluntary Coding System	Target date of July 1, 1991	16 ounces and greater	Numbers 1-7 within a RIS and above a Resin Abbreviation Code	Not Applicable
Alaska	July 1, 1991	16 ounces to 5 gallons	Numbers 1-7 within a RIS and above a standard Resin Abbreviation Code	\$50 per viola- tion, not to exceed \$500
Arizona	July 1, 1991	16 ounces to 5 gallons	Numbers 1-7 within a RIS and above a standard Resin Abbreviation Code	None provided
California	January 1, 1992	16 ounces to 5 gallons	Numbers 1-7 within a RIS and above a standard Resin Abbreviation Code ex- cept an extra 7 is required for mul- tiple layers of a single resin	\$1,000 for man- ufacturers
Colorado	July 1, 1992	16 ounces to 5 gallons	Numbers 1-7 within a RIS and above a standard Resin Abbreviation Code	None provided
Connecticut	January 1, 1990	16 ounces and greater	Statute requires that resin content of container be identified; regulations specify numbers 1-7, standard Resin Abbreviation Code, and permit triang- ular configuration of arrows	None provided
Florida	July 1, 1990	16 ounces to 5 gallons (possible ex- ception for beverage)	Numbers 1-7 within a triangle and above a standard Resin Abbreviation Code except that PET is specified for polyethylene terephthalate	Vague; none provided or \$10,000
Georgia	January 1, 1991	Not specified	Numbers 1-7 within a RIS and above a standard Resin Abbreviation Code	None provided
Hawaii	January 1, 1992	16 ounces to 5 gallons	Numbers 1-7 within a RIS and above a standard Resin Abbreviation Code	None provided
Illinois	January 1, 1991	16 ounces or more	Numbers 1-7 within a RIS and above a standard Resin Abbreviation Code	Maximum civil penalty of \$5,000; suit can be brought by anyone in the county of the violation

**STATE LAW OVERVIEW**  
for  
**Plastic Bottle Coding**  
(continued)

(See separate list for Rigid Plastic Containers)

Jurisdiction	Compliance Date	Minimum and Maximum Size	Recommended/Required Markings	Penalties
Indiana	January 1, 1992	16 ounces or more	Numbers 1-7 within a RIS and above a standard Resin Abbreviation Code	None provided
Iowa	July 1, 1992	16 ounces to 5 gallons	Numbers 1-7 within a RIS and above a standard Resin Abbreviation Code	Civil penalty of \$500 for manufacturers or distributors
Louisiana	January 1, 1991	16 ounces to 5 gallons	Numbers 1-7 within a RIS and above a standard Resin Abbreviation Code	None provided
Maine	July 1, 1991	16 ounces to 5 gallons	Numbers 1-7 above a standard Resin Abbreviation Code; chasing arrows that are used to signify recycling or recycled content are banned only if 6 of 9 named states have enacted a similar ban by January 1, 1991	Civil penalty of \$100
Massachusetts	July 1, 1991	16 ounces to 5 gallons	Numbers 1-7 within a RIS and above a standard Resin Abbreviation Code	None provided
Michigan	January 1, 1992	16 ounces to 5 gallons	Numbers 1-8 within a triangle and above a standard Resin Abbreviation Code except that 7-OTHER only means multilayer and 8-D means degradable	Civil penalty of \$500
Minnesota	To be defined by regulation	16 ounces or more	To be established by regulations that are to be "as consistent as practicable with national industry-wide plastic container coding systems."	After notification, \$50 per violation up to a maximum of \$500
Missouri	January 1, 1992	16 ounces to 5 gallons	Numbers 1-7 within a RIS and above a standard Resin Abbreviation Code	Class A misdemeanor
New Jersey	January 1, 1991	16 ounces to 5 gallons	Numbers 1-7 within a RIS and above a standard Resin Abbreviation Code	Civil Penalty of up to \$500-\$1,000 per day; injunction
North Carolina	July 1, 1991	16 ounces or more	Numbers 1-7 within a RIS and above a standard Resin Abbreviation Code	None provided

**STATE LAW OVERVIEW**  
for  
**Plastic Bottle Coding**  
(continued)

(See separate list for Rigid Plastic Containers)

Jurisdiction	Compliance Date	Minimum and Maximum Size	Recommended/Required Markings	Penalties
North Dakota	December 31, 1991	16 ounces to 5 gallons	Numbers 1-8 within a RIS and above a standard Resin Abbreviation Code except that 7-OTHER only means multilayer and 8-D means degradable and numbers and letters must be 1/2 inch	An infraction
Ohio	January 1, 1991	16 ounces to 5 gallons	Numbers 1-7 within a RIS and above a standard Resin Abbreviation Code	Injunction
Oklahoma	July 1, 1991	16 ounces to 5 gallons	Numbers 1-7 within a RIS and above a standard Resin Abbreviation Code	Misdemeanor
Rhode Island	January 1, 1991	16 ounces to 5 gallons	Numbers 1-7 within a RIS and above a standard Resin Abbreviation Code	None provided
Tennessee	July 1, 1991	16 ounces to 5 gallons	Numbers 1-7 within a RIS and above a standard Resin Abbreviation Code	Warning, then \$50
Texas	July 1, 1991	16 ounces to 5 gallons	Numbers 1-7 within a RIS and above a standard Resin Abbreviation Code	Civil penalty of \$500
Virginia	July 1, 1991	16 ounces to 5 gallons	Numbers 1-7 within a RIS and above a standard Resin Abbreviation Code	\$50 per day of violation
Wisconsin	January 1, 1991	Beverage containers 8 ounces or greater and other bottles 16 ounces and greater	To be established by regulations that are to be "as consistent as practicable with national industry-wide plastic container coding system."	\$500 maximum per day of violation
Wisconsin (continued)	January 1, 1993	8 ounces or more		

**STATE LAW OVERVIEW**  
for  
**Rigid Plastic Container Coding**  
(See separate list for Plastic Bottles)

Jurisdiction	Compliance Date	Minimum and Maximum Size	Recommended/Required Markings	Penalties
Nationwide/ RPCD Voluntary Resin Coding System	Target date of July 1, 1990	8 ounces and greater	Numbers 1-7 within a RIS and above a Resin Abbreviation Code	Not Applicable
Alaska	July 1, 1991	8 ounces to 5 gallons	Numbers 1-7 within a RIS and above a Resin Abbreviation Code	\$50 per viola- tion, not to exceed \$500
Arizona	July 1, 1991	8 ounces to 5 gallons	Numbers 1-7 within a RIS and above a Resin Abbreviation Code	None provided
California	January 1, 1992	8 ounces to 5 gallons	Numbers 1-7 within a RIS and above a standard Resin Abbreviation Code with an extra 7 required for multiple layers of a single material	\$1,000 for man- ufacturers
Colorado	July 1, 1992	8 ounces to 5 gallons	Numbers 1-7 within a RIS and above a standard Resin Abbreviation Code	None provided
Connecticut*	January 1, 1990	16 ounces and greater	Statute requires that resin content of container be identified; regulations specify numbers 1-7, standard Resin Abbreviation Code, and permit trianglu- lar configuration of arrows	None provided
Florida	July 1, 1990	8 ounces or more	Numbers 1-7 within a triangle and above a standard Resin Abbreviation Code ex- cept that PET is specified for poly- ethylene terephthalate but PETE is con- sidered acceptable	Vague; none provided or \$10,000
Georgia	January 1, 1991	Not specified	Numbers 1-7 within a RIS and above a Resin Abbreviation Code	None provided
Hawaii	January 1, 1992	8 ounces to 5 gallons	Numbers 1-7 within a RIS and above a Resin Abbreviation Code	None provided
Illinois	January 1, 1991	8 ounces or more	Numbers 1-7 within a RIS and above a standard Resin Abbreviation Code	Maximum civil penalty of \$5,000; suit can be brought by anyone in the county of the violation

\*Law and regulations refer only to "bottles," not "containers." Bottle is not defined as having any particular shape or contents.

**STATE LAW OVERVIEW**  
for  
**Rigid Plastic Container Coding**  
(continued)

(See separate list for Plastic Bottles)

Jurisdiction	Compliance Date	Minimum and Maximum Size	Recommended/Required Markings	Penalties
Indiana	January 1, 1992	8 ounces or more	Numbers 1-7 within a RIS and above a standard Resin Abbreviation Code	None provided
Iowa	July 1, 1992	8 ounces to 5 gallons	Numbers 1-7 within a RIS and above a standard Resin Abbreviation Code	Civil penalty of \$500 for manufacturers or distributors
Louisiana	January 1, 1991	16 ounces to 5 gallons	Numbers 1-7 within a RIS and above a standard Resin Abbreviation Code	None provided
Maine	July 1, 1991	8 ounces to 5 gallons	Numbers 1-7 above a standard Resin Abbreviation Code; chasing arrows that are used to signify recycling or recycled content are banned only if 6 of 9 named states have enacted a similar ban by January 1, 1991	Civil penalty of \$100
Massachusetts	July 1, 1991	8 ounces to 5 gallons	Numbers 1-7 within a RIS and above a standard Resin Abbreviation Code	None provided
Michigan	January 1, 1992	8 ounces to 5 gallons	Numbers 1-8 within a triangle and above a standard Resin Abbreviation Code except that 7-OTHER only means multilayer and 8-D means degradable	Civil penalty of \$500
Minnesota	To be defined by regulation	16 ounces or more	To be established by regulations that are to be "as consistent as practicable with national industry-wide plastic container coding systems."	After notification, \$50 per violation up to a maximum of \$500
Missouri	January 1, 1992	8 ounces to 5 gallons	Numbers 1-7 within a RIS and above a standard Resin Abbreviation Code	Class A misdemeanor
New Jersey	January 1, 1991	16 ounces to 5 gallons	Numbers 1-7 within a RIS and above a standard Resin Abbreviation Code	Civil Penalty of up to \$500-\$1,000 per day; injunction
North Carolina	July 1, 1991	8 ounces or more	Numbers 1-7 within a RIS and above a standard Resin Abbreviation Code	None provided

**STATE LAW OVERVIEW**  
for  
**Rigid Plastic Container Coding**  
(continued)

(See separate list for Plastic Bottles)

Jurisdiction	Compliance Date	Minimum and Maximum Size	Recommended/Required Markings	Penalties
North Dakota	December 31, 1991	8 ounces to 5 gallons	Numbers 1-8 within a RIS and above a standard Resin Abbreviation Code except that 7-OTHER only means multilayer and 8-D means degradable and numbers and letters must be 1/2 inch	An infraction
Ohio	January 1, 1991	8 ounces to 5 gallons	Numbers 1-7 within a RIS and above a standard Resin Abbreviation Code	Injunction
Oklahoma	July 1, 1991	8 ounces to 5 gallons	Numbers 1-7 within a RIS and above a standard Resin Abbreviation Code	Misdemeanor
Rhode Island	January 1, 1991	8 ounces to 5 gallons	Numbers 1-7 within a RIS and above a standard Resin Abbreviation Code	None provided
Tennessee	July 1, 1991	8 ounces to 5 gallons	Numbers 1-7 within a RIS and above a standard Resin Abbreviation Code	Warning, then \$50
Texas	July 1, 1991	8 ounces to 5 gallons	Numbers 1-7 within a RIS and above a standard Resin Abbreviation Code	Civil penalty of \$500
Virginia	July 1, 1992	8 ounces to 5 gallons	Numbers 1-7 within a RIS and above a standard Resin Abbreviation Code	\$50 per day of violation
Wisconsin	January 1, 1991	16 ounces or more	To be established by regulations that are to be "as consistent as practicable with national industry-wide plastic container coding system."	\$500 maximum per day of violation
Wisconsin (continued)	January 1, 1992	8 ounces or more		



**PLASTIC CONTAINER CODING SUMMARIES**



## SPI VOLUNTARY GUIDELINES

1. **Compliance Target:** July 1, 1991 for bottles  
July 1, 1990 for containers

2. **Scope:**

<u>Type</u>	<u>Size</u>
<u>Plastic Bottles</u>	No less than 16 ounces
<u>Rigid Plastic Containers</u>	No less than 8 ounces

3. **Recommended Codes:**

<u>Resin Type</u>	<u>Code Number</u>	<u>Code Letters</u>
Polyethylene Terephthalate	1	PETE
High Density Polyethylene	2	HDPE
Vinyl	3	V
Low Density Polyethylene	4	LDPE
Polypropylene	5	PP
Polystyrene	6	PS
Other (including multi-material)	7	OTHER

- A. Base cups and labels: If the materials are compatible in recycling systems, the basic material code of the bottle should be used (even when the basic code is applied to the base cup of the secondary material); otherwise, "7-OTHER" is appropriate.
- B. Multilayer: Included in "7-OTHER" only if the container includes materials that are incompatible with recycling systems for the predominant resin.

4. **Recommended Symbol:** A Resin Identification Symbol (RIS) (See "LEGEND"). Defined by diagram.

5. **Recommended Location of Symbol:** On or as near to the bottom of the bottle or container as technically feasible.

6. **Penalties:** None

7. **Additional Information:**

John C. Malloy  
Director of Packaging Services  
The Society of the Plastics Industry, Inc.  
1275 K Street, N.W.  
Washington, D. C. 20005

8. **Attachment:** Technical Bulletins PBI-24 and RPCD-13



## Technical Bulletin

### VOLUNTARY GUIDELINES PLASTIC BOTTLE MATERIAL CODE SYSTEM— MOLD MODIFICATION DRAWINGS

**PBI-24-1988**  
Revision 2  
Oct. 1, 1990



PETE



HDPE



V



LDPE



PP



PS



OTHER

### CONTENTS

1. Purpose	Page 1	6. Qualifications	Page 5
2. Background	Page 2	7. Symbol Location Guidelines	Page 6
3. Design and Use	Page 3	8. Photo Masters	Page 7
4. Mold Modification	Page 4	9. Engraving Masters	
5. Imprinting	Page 5	Symbol Numbers	Page 9
			Page 11

### 1.0 PURPOSE

The Society of the Plastics Industry (SPI) has developed a voluntary coding system for plastic containers, to identify material type. The purpose of coding is to assist recyclers in sorting plastic containers by resin composition. The system is intended for voluntary use by bottle and container producers, to be molded or otherwise imprinted onto the bottom surface of plastic containers.

This container coding system has been created and is recommended to the industry to provide a consistent national identification mark that meets the needs of the

recycling industry, as defined by the recyclers and collectors themselves.

The system is designed to be most convenient for the people who will sort containers, and is intended to avoid a complicated system which would require extensive worker training and possibly lead to confusion and/or mis-sorting.

Given today's national marketplace, it is crucial that the coding system be standardized nationally. The use of different code systems by various companies or states could significantly disrupt the flow of commerce.

To the best of our knowledge the information contained herein is accurate. However, The Society of the Plastics Industry, Inc. assumes no liability whatsoever for the accuracy or completeness of the information contained herein. Final determination of the suitability of any information or material for the use contemplated, the manner of use and whether there is any infringement of patents is the sole responsibility of the user.

This test method or practice may involve hazardous materials, operations and equipment. This test method does not purport to address all of the safety measures associated with its use. It is the responsibility of the user of this method to establish appropriate safety and health practices and determine the applicability of any federal, state, and local regulatory limitations prior to use.

---

---

## 2.0 BACKGROUND

---

---

### **The Problem of Solid Waste**

One of our most pressing environmental issues is the mounting problem of solid waste disposal. Communities across the country are having to face the issue of how to dispose of a growing volume of municipal waste efficiently and responsibly. In many areas, the lack of landfill space or proper incineration facilities has created the need to reduce the volume of household waste.

### **The Role of Recycling**

More and more, recycling is playing a role in solving community waste disposal problems. Many states, counties, cities and smaller communities are recognizing that recycling can noticeably reduce the volume of waste to be handled by landfills and incinerators. They note recycling can also save on landfill tipping fees and transportation costs, and reuse valuable natural resources. Many new laws, regulations and public education programs are designed to encourage consumer participation in community recycling projects.

### **Recycling Plastic Bottles**

Plastic bottles are not a large part of the waste stream, but their use is growing. Currently almost a third of municipal waste is paper products, with another third being organic and food waste. Plastic materials of all kinds represent about seven percent, half of which is plastic packaging. Plastic bottles, however, are one of the components of household trash which can be recycled, along with newspapers, aluminum cans and glass containers.

The predominant plastic recycling systems in place today are geared to handling separate plastic materials, which are primarily polyethylene terephthalate (PET) from soft drink bottles and high density polyethylene (HDPE) from milk bottles. Markets for these materials are well developed, and increased volume should be possible. This has come about because soft drink and milk bottles are readily identified by their size, shape and color, and are easily separated from other plastic bottles. They are also available in large volume, together representing more than one third of all plastic bottles.

The remaining volume of plastic bottles are made from a variety of resin materials, including PET and HDPE. These, however, are not as readily identifiable by size and style, and are not easily separated for processing by the current recycling systems. The challenge to the plastics industry has been to assist in solving the solid waste disposal problem by finding a way to make these other plastic bottles, and other containers, more recyclable.

### **Needs of Recyclers**

To determine the most appropriate way to aid recyclers and collectors to separate plastic containers for processing, a survey was conducted among a large portion of the recycling industry. The results indicated that while not all recyclers could handle sorting, a significant portion would benefit by having a system to visually identify container material. After evaluating various methods, this recommended system was determined to be the most practical and the most helpful to recyclers and collectors.

The code system identifies the six most common plastic container materials, and applies to large containers representing perhaps 70% of all bottle resin. This is intended to encourage sorting which will result in reasonable volumes of higher value recycled material. All other large containers, including multi-material, can be grouped with smaller containers and can be recycled as "mixed" plastics. This is a recently-developed successful technology which is in use in some areas and is expected to grow.

### 3.0 DESIGN AND USE

The plastic bottle material code system is designed to be easy to read at a glance and distinguishable from existing marks put on plastic bottles by manufacturers for use in processing and identification. The basic part of the system uses a triangular-shaped symbol composed of three arrows, with a specific number in the center to indicate the material from which the bottle is made. The number-material equivalents are these:

- 1 — PETE = poly-ethylene terephthalate (PET)\*
- 2 — HDPE = high density polyethylene
- 3 — V = vinyl/polyvinyl chloride (PVC)\*
- 4 — LDPE = low density polyethylene
- 5 — PP = polypropylene
- 6 — PS = polystyrene
- 7 — OTHER = all other resins

The number code is then supplemented by the common letter identification for the various resins under the symbol, to serve as a constant verification of the material sorted, and for additional identification of actual material when necessary.

It is the responsibility of the container producer to select the appropriate code for bottles with base cups or other components of a secondary material. Where it is known that such a container is compatible in current recycling systems with other containers of the basic material, that basic material code may be used, even if applied to a base cup of the secondary material. Otherwise, code "7—OTHER" should be used.

- The bottle code letters for polyethylene terephthalate and polyvinyl chloride are different from the standard industry identification letters in order to avoid confusion with registered trademarks.

**3.1 Application** The material code should be molded into or imprinted on all plastic bottles 16 ounces and larger, on or as near to the bottom as is technically feasible. The minimum sized symbol will not fit smaller bottles, and recyclers have indicated the cost of sorting smaller bottles is greater than the value gained.

**3.2 Voluntary Timing** The material identification code is intended to be molded into all plastic bottles of appropriate size, including those made from existing molds. To accommodate this procedure without substantial disruption of production schedules, it is suggested that molds can generally be modified to add the code at a time they would be off-line for other reasons. The Plastic Bottle Institute is recommending conversion per the following schedule:

NEW TOOLING — During fabrication

EXISTING TOOLING —

30% of current molds within 12 months

60% of current molds within 24 months

100% of current molds within 36 months

**3.3 Size** Symbol size should be a minimum of 1/2 inch and a maximum of 1 inch, for ease of reading at a glance and consistency. Smaller sized symbols may be used on bottles with special or restrictive base or bottom designs. Specific size recommendations are as follows:



1/2" Symbol for 16 fl. oz.  
to 32 fl. oz. bottles

PETE

3/4" Symbol for 32 fl.  
oz. to 1 gal. bottles



HDPE

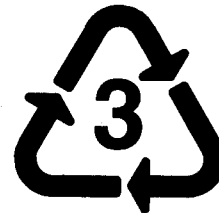

1" Symbol for 1 gal.  
and larger bottles

V

## 4.0 MOLD MODIFICATION

New and existing molds should be marked by one of two methods, stamping or engraving, the selection depending on the mold material and the flatness of the bottom plate surface.

**4.1 Mold Stamping** Some new and existing molds, with bottom plates which are not hardened, may be marked with a hardened stamp. (See illustration below.)



**Applying Mold Marking with Stamp**

Care should be taken to firmly hold the stamp, to insure a good impression of .010 to .012 in. depth for satisfactory readability of the molded symbol.

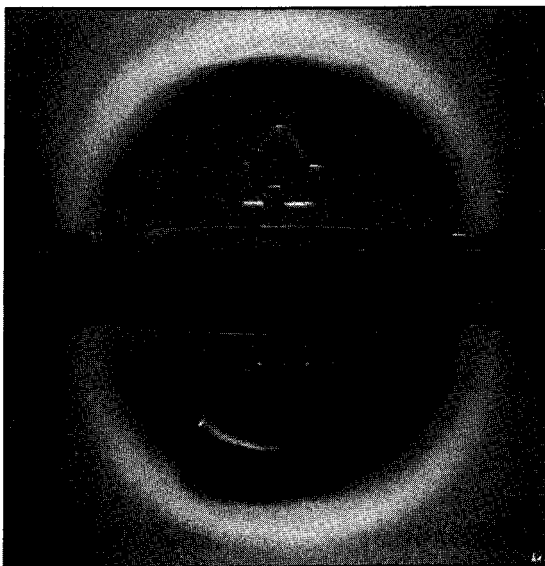

**Mold Stamped with Symbol**

Hardened stamps may be purchased from a quality engraving shop familiar with stamp fabrication techniques. Alternately, an experienced mold maker

may be consulted for assistance in marking, or locating stamps.

This method will not be satisfactory for molds where the minimum size symbol must be applied to a curved surface. Engraving must be used in this case.

**4.2 Mold Engraving** Molds that have hardened bottom plates or pinchers, or where the surface to be marked is not flat, will not be able to be marked using the stamping method. These will need to have the symbol applied by engraving.

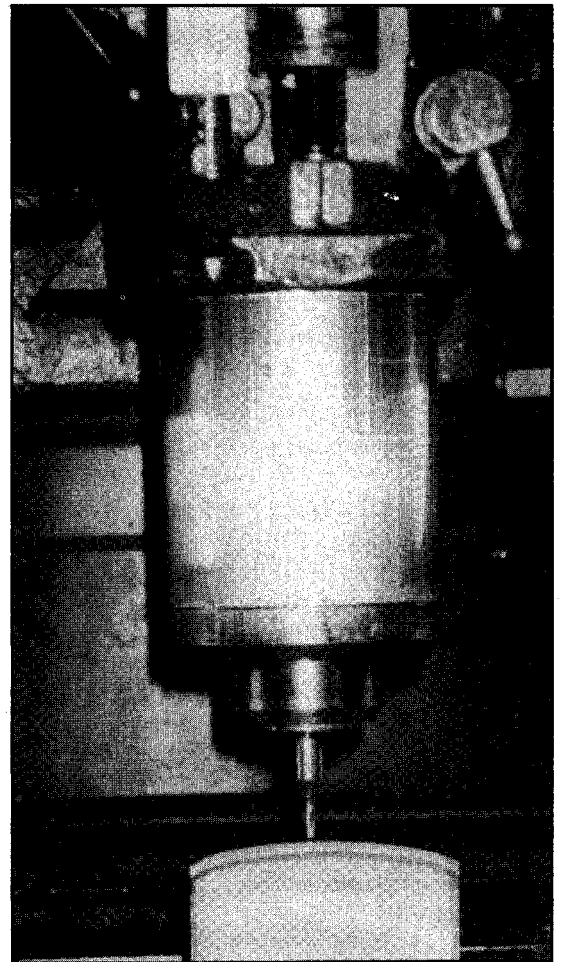

**Engraving Machine Application of Mark**

Engraving can be done by most mold makers, or by an engraving shop familiar with mold fabrication techniques for injection and blow molding.

Master drawings for the creation of engraving masters are included with this technical bulletin. The symbol drawing and numbers/lettering drawing are separate, both at 8x scale for 1/2" symbol. Complete full scale photo masters are also included for convenient use for this or other purposes.



### 4.3 Bottle Appearance



Finished Bottles with Molded Code

### 5.0 IMPRINTING

Under special circumstances where mold modification is not technically feasible, the symbol may be imprinted on the bottom of the container through the use of appropriate container marking or decorating equipment suitable for logos or special symbols. Care should be taken to use permanent inks, applied to bottom surfaces appropriately conditioned to retain the mark through the entire container handling system to the recycler.

### 6.0 QUALIFICATIONS

**6.1 Implementation** The Society of the Plastics Industry, Inc., (SPI) is promoting a voluntary guideline for a plastic container material code system as a public service. The plastics and packaging industries, recyclers and the general public will be informed of the system through news releases, copies of this technical bulletin, or other appropriate means. The system is available to any company or person to use as appropriate. However, use of the system is voluntary. SPI is not responsible for implementation of the system by container producers or users. Proper use of the system is the sole responsibility of each manufacturer that chooses to use it.

**6.2 Recyclability of Containers** Neither the recommendations of SPI to code containers by material, nor the presence of a resin code on a container, conveys any guarantee, either expressed or implied, that any particular container is suitable for recycling into any particular product. The suitability

of a recycled resin for a particular application will depend upon the demand of the application and the nature of any contamination resulting from prior container use. Furthermore, even within a resin type, virgin materials are manufactured with specific properties to meet the needs of specific applications. It is expected that the initial market for recycled resins will be for those applications that are tolerant of the variations in properties that exist among the various resins of each type that are represented in the waste stream.

**6.3 Change in Material** If the resin used to produce a particular style of container is changed, it is the responsibility of the manufacturer to change the code to match the new resin. As noted above, use of the symbols on plastic containers is totally voluntary, and producers are free to change resins for particular containers as they see fit. The code is intended to relate solely to the resin type from which the container is made, and does not relate to the contents of the container, its shape or appearance.

**6.4 Legal Status** The plastic container material code guidelines are intended to promote uniform identification of resin materials in the absence of conflicting requirements. SPI does not guarantee that use of these guidelines will assure compliance with requirements of every jurisdiction that has adopted a resin coding law. Discrepancies that exist between state laws and the voluntary guidelines are highlighted in PBI's "Report on State Laws, Plastic Container Material Coding" available from the SPI Literature Sales Department.

**7.0 SYMBOL LOCATION GUIDELINES**

Locate symbol to not interfere with the full circular path of the decorating detent. Also, interfere as little as possible with the "clear area" customers may specify for product date coding or other purposes.

**BOTTOM VIEWS OF TYPICAL 16 OZ. BOTTLES**

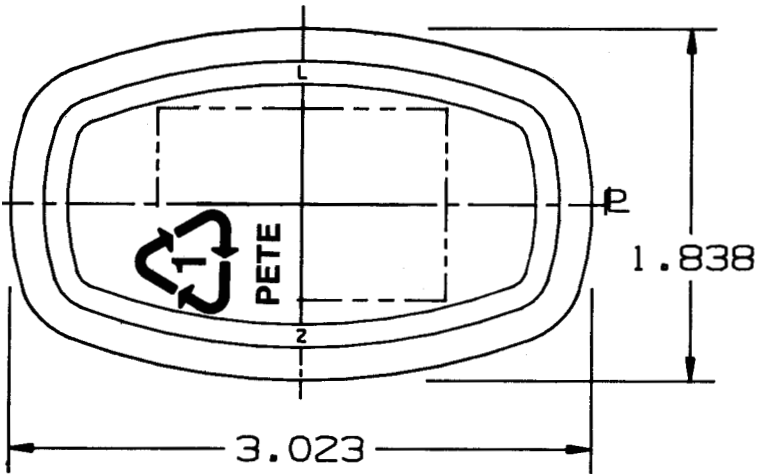

**OBLONG**

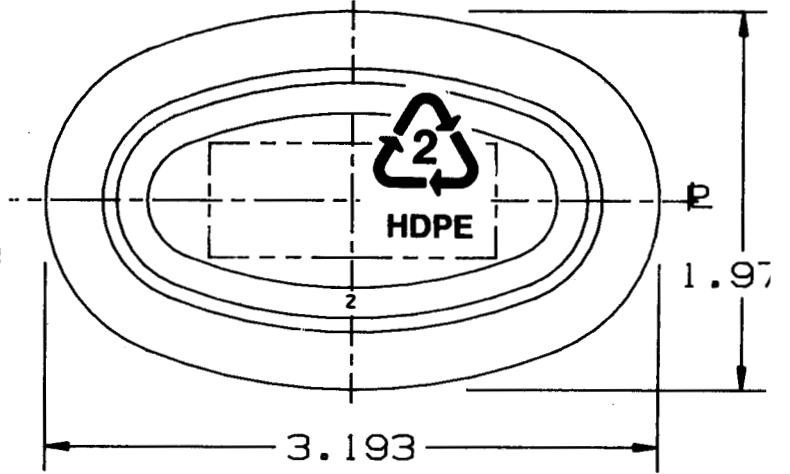

**OVAL**

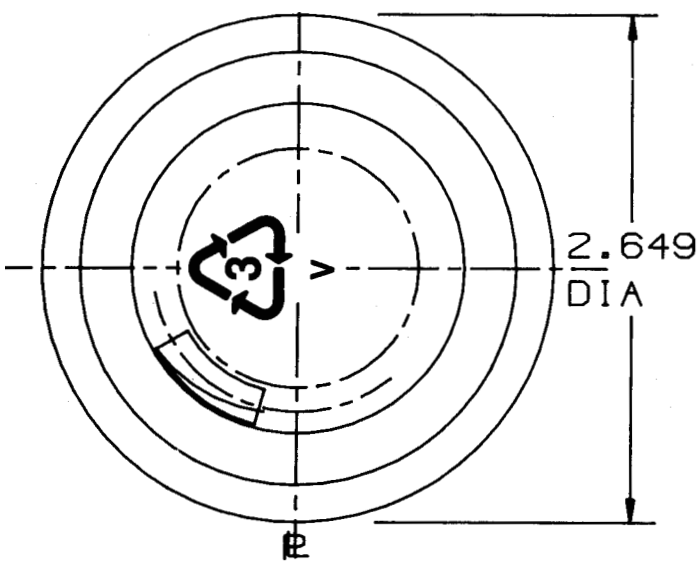

**ROUND**

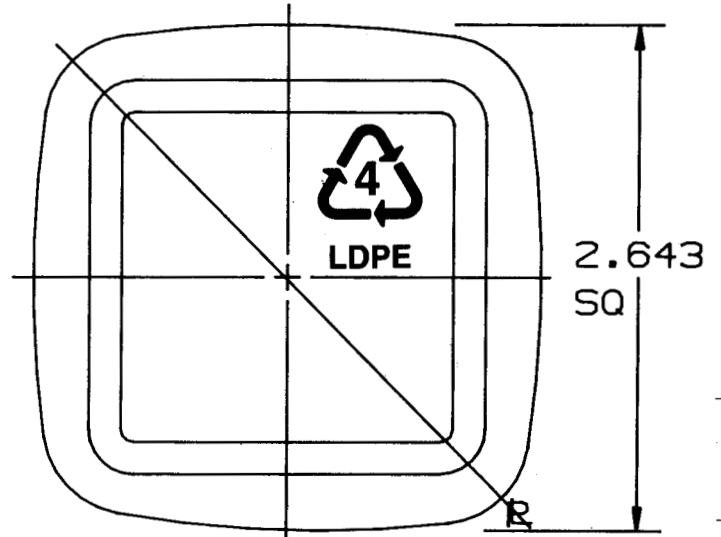

**SQUARE**

8.0 PHOTO MASTERS

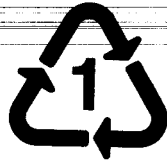

PETE

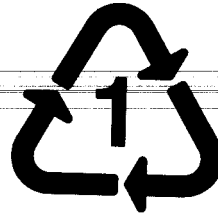

PETE



PETE



HDPE



HDPE



HDPE



V

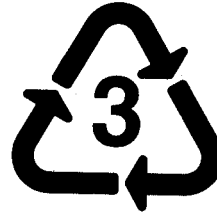

V



V



LDPE



LDPE



LDPE



PP



PP



PP



PS



PS



PS



OTHER



OTHER



OTHER

**SECTION A-A**

**9.0 ENGRAVING MASTERS**

**9.1 Symbol**

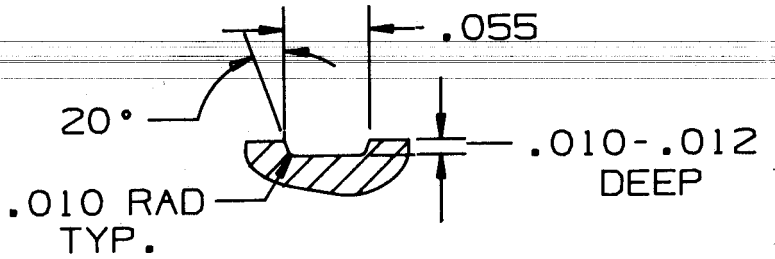

**ALL CHARACTERS IN HELVETICA BOLD**

SIZE OF SYMBOL	APPROXIMATE PRINTING POINT SIZE	
	NUMBERS	LETTERS
1/2"	13	9
3/4"	20	13
1"	26	17

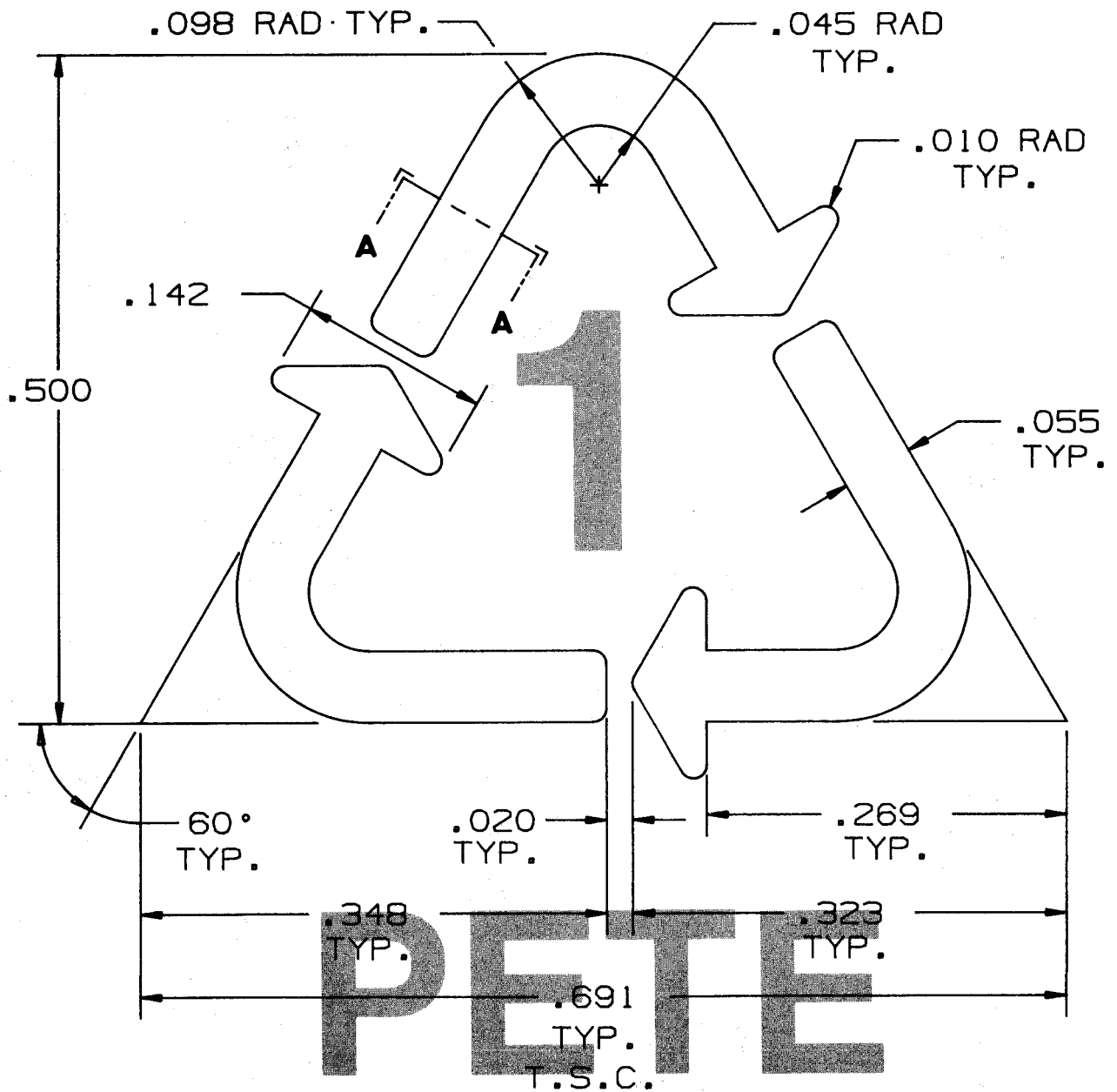

REFERENCE DRAWING FOR CONSTRUCTION OF ENGRAVING MASTER (SCALE 8 x 1/2" SYMBOL)

9.0 ENGRAVING MASTERS

9.2 Numbers & Letters

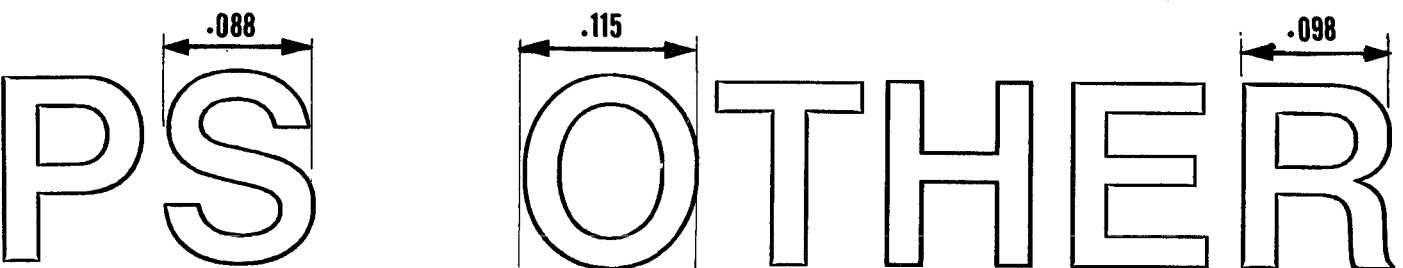
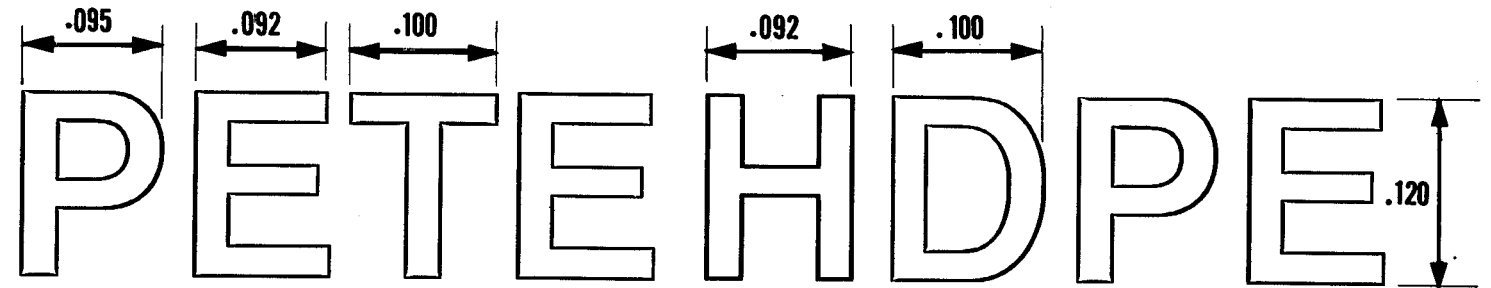
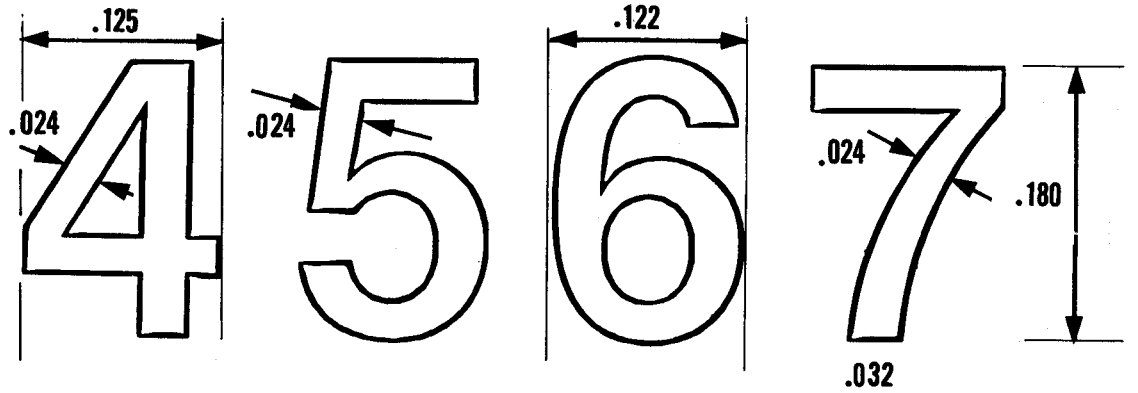
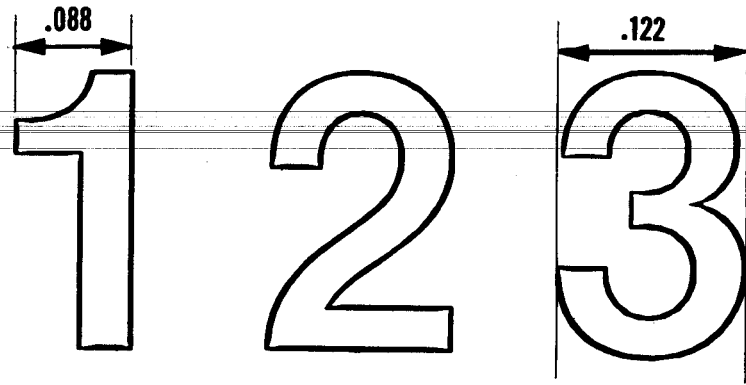

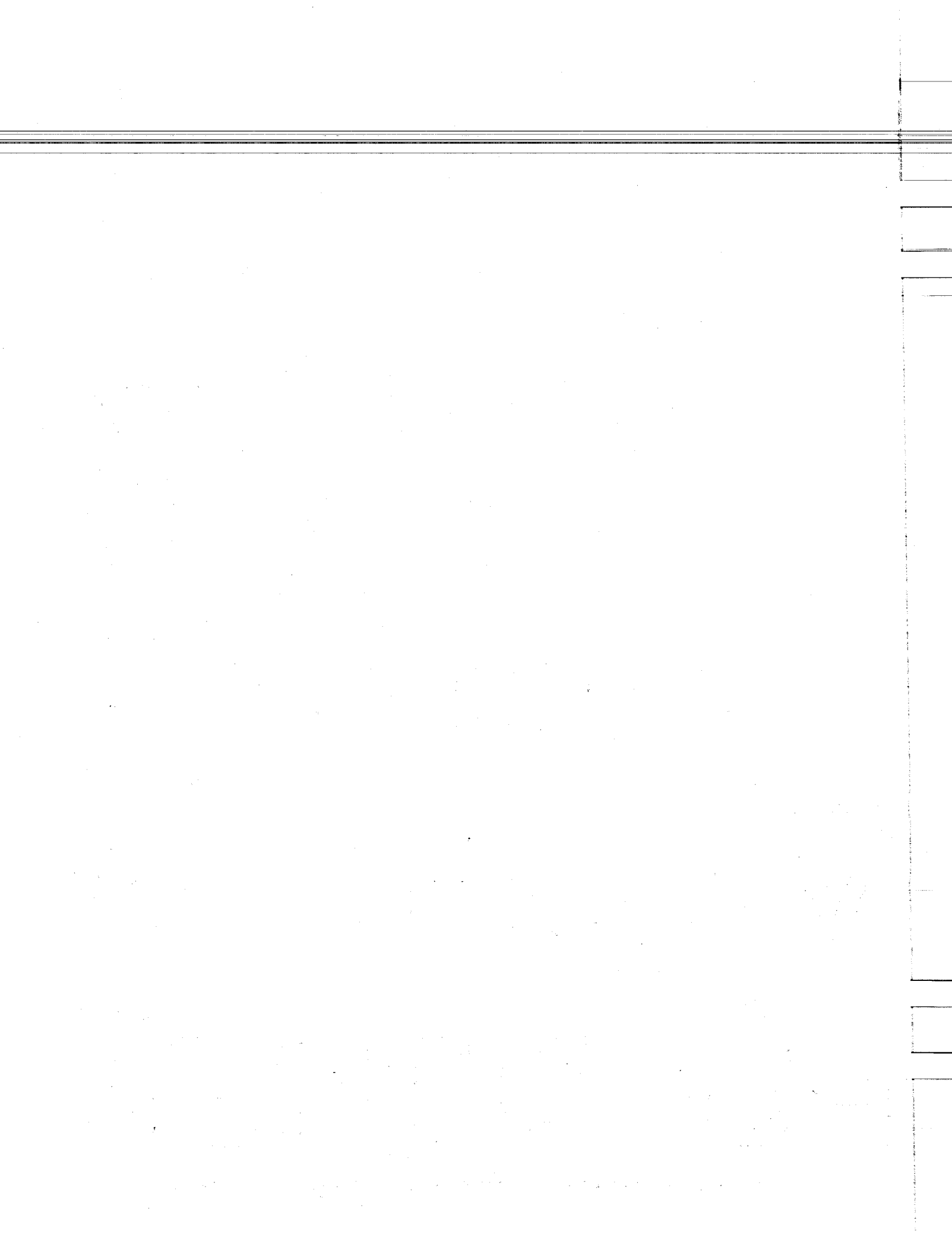

# Rigid Plastic Container Division

1275 K Street, N.W., Suite 400  
Washington, D.C. 20005  
(202) 371-5200  
FAX 371-1022

RPCD-13-1989  
Revision 1  
October 1, 1990

## Technical Bulletin

### Voluntary Guidelines Rigid Plastic Container Material Code System: Mold Modification Drawings



PETE



HDPE



V



LDPE



PP



PS



OTHER

#### Contents

1. Purpose.....	Page 1	6. Qualifications.....	Page 5
2. Background.....	Page 2	7. Symbol Size/Location Guidelines.....	Page 6
3. Design and Use.....	Page 3	8. Photo Masters.....	Page 7
4. Mold Modification.....	Page 4	9. Engraving Masters	
5. Imprinting.....	Page 5	<i>Symbol</i> .....	Page 9
		<i>Numbers &amp; Letters</i> .....	Page 11

### 1.0 PURPOSE

The Society of the Plastics Industry (SPI) has developed a voluntary coding system for plastic containers, to identify material type. The purpose of coding is to assist recyclers in sorting plastic containers by resin composition. The system is intended for voluntary use by bottle and container producers, to be molded or formed or otherwise imprinted onto the bottom surface of plastic containers.

This container coding system has been created and is recommended to the industry to provide a consistent national identification mark that meets the

needs of the recycling industry, as defined by the recyclers and collectors themselves. The system is designed to be most convenient for the people who will sort containers, and is intended to avoid a complicated system which would require extensive worker training and possibly lead to confusion and/or mis-sorting.

Given today's national marketplace, it is crucial that the coding system be standardized nationally. The use of different code systems by various companies or states could significantly disrupt the flow of commerce.

To the best of our knowledge the information contained herein is accurate. However, The Society of the Plastics Industry, Inc. assumes no liability whatsoever for the accuracy or completeness of the information contained herein. Final determination of the suitability of any information or material for the use contemplated, the manner of use and whether there is any infringement of patents is the sole responsibility of the user.

This test method or practice may involve hazardous materials, operations and equipment. This test method does not purport to address all of the safety measures associated with its use. It is the responsibility of the user of this method to establish appropriate safety and health practices and determine the applicability of any federal, state, and local regulatory limitations prior to use.

## 2.0 BACKGROUND

### *THE PROBLEM OF SOLID WASTE*

One of the most pressing environmental issues is the mounting problem of solid waste disposal. Communities across the country are facing the issue of how to dispose of a growing volume of municipal waste efficiently and responsibly. In many areas, the lack of landfill space or proper incineration facilities has created the need to reduce the volume of household waste.

### *THE ROLE OF RECYCLING*

More and more, recycling is playing a role in solving community waste disposal problems. Many states, counties, cities and smaller communities are recognizing that recycling can noticeably reduce the volume of waste to be handled by landfills and incinerators. They note recycling can also save on landfill use fees and transportation costs, and reuse valuable natural resources. Many new laws, regulations and public education programs are designed to encourage consumer participation in community recycling projects.

### *RECYCLING RIGID PLASTIC CONTAINERS*

Rigid Plastic Containers are injection molded or thermoformed containers used to package and deliver any product to a customer, including food service packages. Rigid plastic containers are not a large part of the waste stream, but their use is growing. Currently, almost a third of municipal waste is paper products, with another third being organic and food waste. Plastic materials of all kinds represent about seven percent of the municipal waste stream, half of which is plastic packaging. Plastic containers, however, are one of the components of household trash which can be recycled, along with newspapers, aluminum cans and glass containers.

The predominant plastic recycling systems in place today are geared towards handling separate plastic materials, which are primarily polyethylene terephthalate (PET) from soft drink bottle and high density polyethylene (HDPE) from milk bottles. Markets for these materials are well developed, and increased volume should be possible. This has come about because soft drink and milk bottles are readily identified by their size, shape and color, and are easily separated from other plastic containers. They are also available in large volume, together representing more than one third of all plastic bottles.

The remaining volume of plastic containers are made from a variety of resin materials, including PET and HDPE. These, however, are not readily identifiable by size and style, and are not easily separated for processing by the current recycling systems. The challenge to the plastics industry has been to assist in solving the solid waste disposal problem by finding a way to make these other plastic containers more recyclable.

### *NEEDS OF RECYCLERS*

To determine the most appropriate way to aid recyclers and collectors to separate plastic containers for processing, a survey was conducted among a large portion of the recycling industry. The results indicated that while not all recyclers could handle sorting, a significant portion would benefit by having a system to visually identify container material. After evaluating various methods, this recommended system was determined to be the most practical and the most helpful to recyclers and collectors.

The code system identifies the six most common plastic container materials, and applies to large containers representing perhaps 70 percent of all container resin. This is intended to encourage sorting which will result in reasonable volumes of higher value recyclable material. All other large containers, including multi-material, can be grouped with smaller containers and can be recycled as "mixed" or "other" plastics. A recently-developed successful technology which makes use of these mixed plastics is in use in some areas and is expected to grow.



### 3.0 DESIGN AND USE

The Rigid Plastic Container Material Code System is designed to be easy to read at a glance and distinguishable from existing marks put on rigid plastic containers by manufacturers for use in processing and identification. The basic part of the system uses a triangular-shaped symbol composed of three arrows with a specific number in the center to indicate the material from which the container is made. The number-material equivalents are:

- 1 = PETE (polyethylene terephthalate) (PET)<sup>1</sup>
- 2 = HDPE (high density polyethylene)
- 3 = V (vinyl/polyvinyl chloride) (PVC)<sup>1</sup>
- 4 = LDPE (low density polyethylene)
- 5 = PP (polypropylene)
- 6 = PS (polystyrene)
- 7 = OTHER

The number code is then supplemented by the common letter identification for the various resins under the symbol, to serve as a constant verification of the material sorted, and for additional identification of actual material when necessary.

<sup>1</sup> The container code letters for polyethylene terephthalate and polyvinyl chloride are different from the standard industry identification letters in order to avoid confusion with registered trademarks.

#### 3.1 Application

**3.1.1 Containers** — The material code should be molded, formed or imprinted on all containers that are large enough to accept the 1/2 inch-minimum size symbol. In any case, the symbol should be applied to all containers of eight ounce size or larger. The code should be on the bottom of the container, as close to the center as is feasible considering design, other marks, and customer requirements for clear areas. Placing the code in a similar location on all containers will allow those sorting them to quickly locate the code and identify the material.

Containers consisting of more than one resin may carry the code of the basic resin if the combination of materials is known to perform the same as the basic material in current recycling systems and

normal reuse applications. Otherwise, use of the code "7 OTHER" is recommended.

**3.1.2 Lids** — It is recommended the material code be applied to all lids of 50 in.<sup>2</sup> or larger. The code should be applied on the top or the underside of the lid, as close to the center as possible. Producers may voluntarily put the code on lids smaller than 50 in.<sup>2</sup>, so long as the minimum 1/2 inch symbol size is maintained.

#### 3.2 Voluntary Timing

The material identification code is intended to be molded or formed into all rigid plastic containers of appropriate size, including those made from existing molds. To accommodate this procedure without substantial disruption of production schedules, it is suggested that molds can generally be modified to add the code at a time they would be off-line for other reasons. **However, the Rigid Plastic Container Division is recommending that all appropriate container and lid molds be modified by JULY 1, 1990.**

#### 3.3 Symbol Size

**3.3.1 Containers** — The size of the triangular arrow symbol should be a minimum of 1/2 inch and a maximum size of 2 inches, to which letters under the symbol are added, for ease of reading at a glance and for consistency. Smaller sized symbols may be used on eight ounce and larger containers with special or restrictive base or bottom designs. This recommendation does not include using smaller sized symbols on containers less than eight ounces. Specific size recommendations are as follows:



PETE

*1/2 inch symbol for any container up to 34 fluid ounces*



HDPE

*3/4 inch symbol for 34 fluid ounces up to one gallon containers*



V

*1-2 inch symbol for one gallon and larger containers, actual symbol size being proportionate to the size of the container bottom*

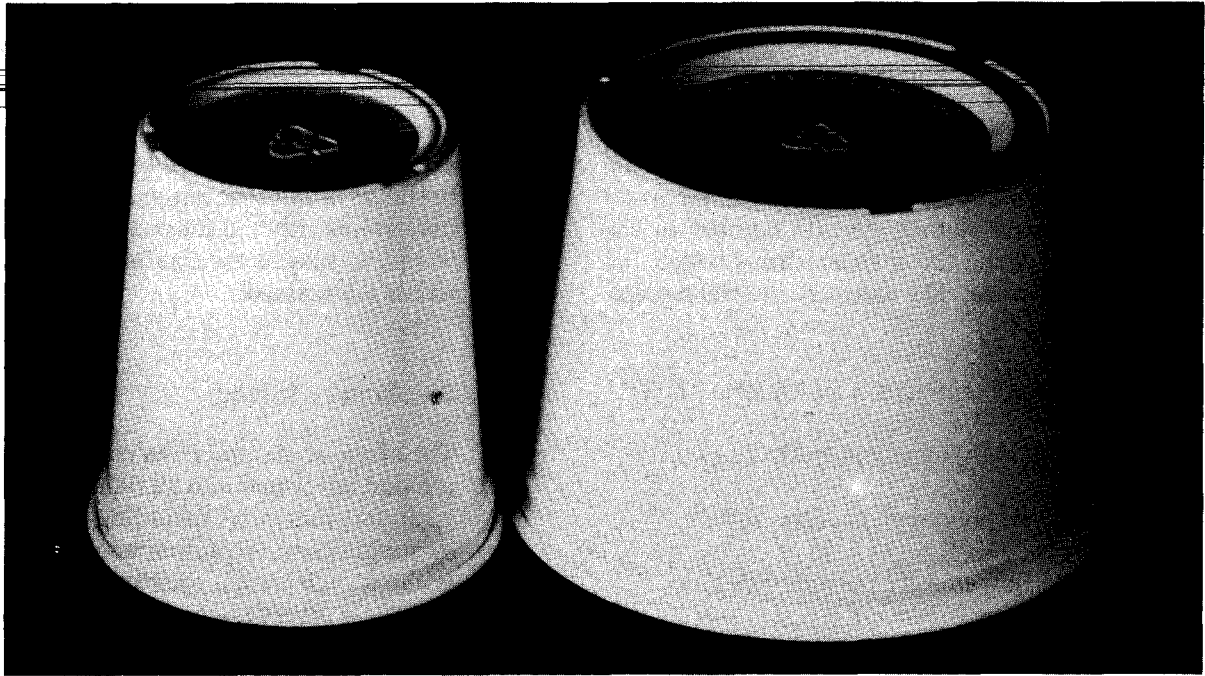

8 Ounce and 16 Ounce Rigid Plastic Containers With Molded Codes

**3.3.2 Lids** — Symbol size should be a minimum of 1/2 inch on lids of 50 in.<sup>2</sup> and a maximum size of two inches, the actual size being proportionate to the area of the lid.

## 4.0 MOLD MODIFICATION

### 4.1 Containers

New and existing molds used in either injection molding or thermoforming should be marked by one of several methods: stamping, engraving or sandblasting. The selection of the method depends on the material and the flatness of the mold surface and on the capabilities of the mold shop.

**4.1.1 Mold Stamping** — Some new and existing molds, with mold surfaces which are not hardened, may be marked with a hardened stamp.

Care should be taken to firmly hold the stamp to insure a good impression overall with sufficient depth for satisfactory readability of the molded symbol. This depth may be from .003 to .012 of an inch, depending on the contrast with the surrounding surface.

Hardened stamps may be purchased from a quality engraving shop familiar with stamp fabrication techniques. Alternately, an experienced moldmaker may be consulted for assistance in

making or locating stamps.

This method will not be satisfactory for molds where the symbol must be applied to a curved surface.

**4.1.2 Mold Engraving** — Molds that have hardened surfaces, or where the surface to be marked is not flat, will not be able to be marked using the stamping method. These will need to have the symbol applied by a different method such as engraving.

Engraving can be done by most moldmakers or by an engraving shop familiar with mold fabrication techniques for injection molding and thermoforming.

Master drawings for the creation of engraving masters are included with this technical bulletin. The symbol drawing and numbers/letters drawings are separate, both at eight times scale for a 1/2 inch symbol. Complete full scale photo masters are also included for convenient use for this or other purposes.

**4.1.3 Sandblasting** — Sandblasting the symbol onto the mold can be done by most mold shops.

On some molds, particularly thermoforming molds, the mold surface is already sandblasted and the use of a sandblasted symbol would not be readily visible. When modifying existing sandblasted molds, the symbol should be engraved.

For new molds, the symbol should be stamped or engraved prior to sandblasting the mold surface. The symbol should then be masked for protection during the sandblasting operation.

## 4.2 Container Lids

Most new and existing molds for container lids should be marked by one of two methods, sandblasting or polishing — the selection depending on the surface of the mold. When lids need to be clear for printing or decorating, they should not be stamped or engraved because these methods may have a tendency to disturb the surface. When decorating is not a factor, lid molds may be modified by any appropriate means.

Both sandblasted and polished molds may have a tendency to wear and may require increased maintenance for continued clarity of the symbol.

## 5.0 IMPRINTING

Under special circumstances where mold modification is not technically feasible, the symbol may be imprinted on the bottom of the container or the top of the lid through the use of appropriate container marking or decorating equipment suitable for logos or special symbols. Care should be taken to use permanent inks, applied to surfaces appropriately conditioned to retain the mark through the entire container handling system to the recycler. This method should not be used to mark the underside of lids where the contents of the container may come in contact with the imprint.

## 6.0 QUALIFICATIONS

### 6.1 Implementation

The Society of the Plastics Industry, Inc., (SPI) is promoting a voluntary guideline for a plastic container material code system as a public service. The plastics and packaging industries, recyclers and the general public will be informed of the system through news releases, copies of this technical bulletin, or other appropriate means. The system is available to any company or person to use as appropriate.

However, use of the system is voluntary. SPI is not responsible for implementation of the system by container producers or users. Proper use of the system is the sole responsibility of each manufacturer that chooses to use it.

## 6.2 Recyclability of Containers

Neither the recommendations of SPI to code containers by material, nor the presence of a resin code on a container, conveys any guarantee, either expressed or implied, that any particular container is suitable for recycling into any particular product. The suitability of a recycled resin for a particular application will depend upon the demands of the application and the nature of any contamination resulting from prior container use. Furthermore, even within a resin type, virgin materials are manufactured with specific properties to meet the needs of specific applications. It is expected that the initial market for recycled resins will be for those applications that are tolerant of the variations in properties that exist among the various resins of each type that are represented in the waste stream.

## 6.3 Change in Material

If the resin used to produce a particular style of container is changed, it is the responsibility of the manufacturer to change the code to match the new resin. As noted above, use of the symbols on plastic containers is totally voluntary, and producers are free to change resins for particular containers as they see fit. The code is intended to relate solely to the resin type from which the container is made, and does not relate to the contents of the container, its shape or appearance.

## 6.4 Legal Status

The plastic container material code guidelines are intended to promote uniform identification of resin materials in the absence of conflicting requirements. SPI does not guarantee that use of these guidelines will assure compliance with requirements of every jurisdiction that has adopted a resin coding law. Discrepancies that exist between state laws and the voluntary guidelines are highlighted in Plastic Bottle Institute's "Report on State Laws, Plastic Container Material Coding" available from the SPI Literature Sales Department.

## 6.5 State Mandatory Coding Requirements

Since this voluntary resin coding system was developed, a number of states have adopted mandatory resin coding requirements. SPI makes no representation, expressed or implied, that the voluntary system will satisfy specific state requirements. Each manufacturer, distributor and user of rigid plastic containers is responsible for determining the coding requirements and compliance deadlines applicable to it and the containers it makes, distributes or uses.

### 7.0 SYMBOL SIZE/LOCATION GUIDELINES

Symbols should be located as close to the center of the container bottom as is feasible. This is necessary to achieve national consistency among a large variety of rigid container styles. These illustrations are general guidelines for selection of appropriate sizes and location of symbols on other container styles.

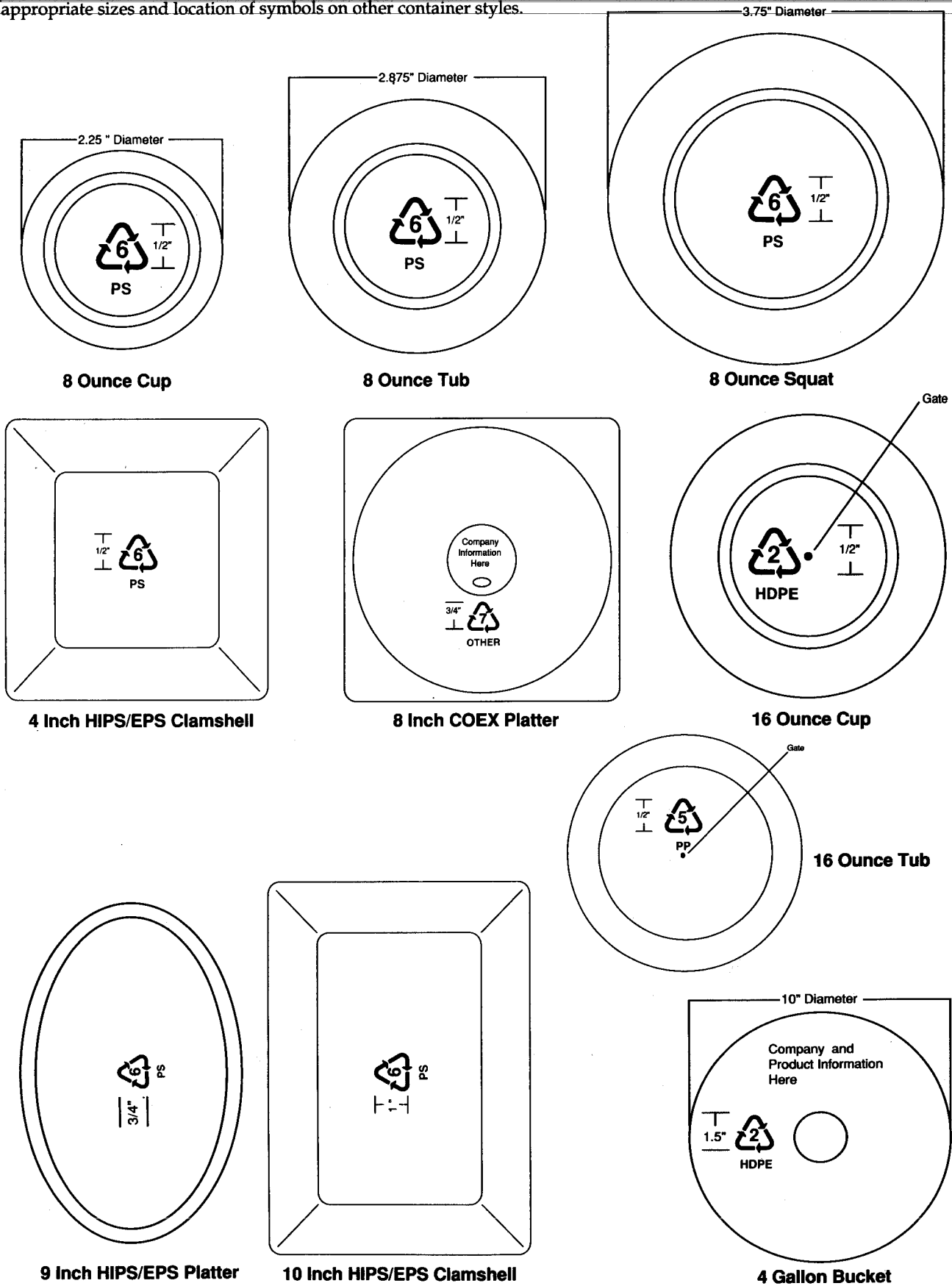

8.0 PHOTO MASTERS



PETE

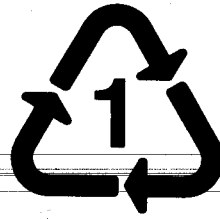

PETE



PETE



HDPE



HDPE



HDPE



V



V



V



LDPE

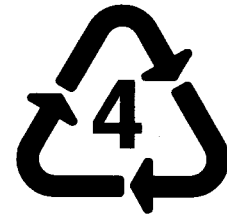

LDPE



LDPE



PP



PP



PP



PS



PS



PS



OTHER

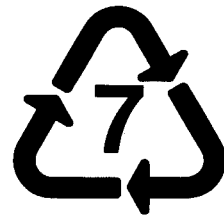

OTHER



OTHER

9.0 ENGRAVINGS MASTERS

9.1 Symbol

**SECTION A-A**

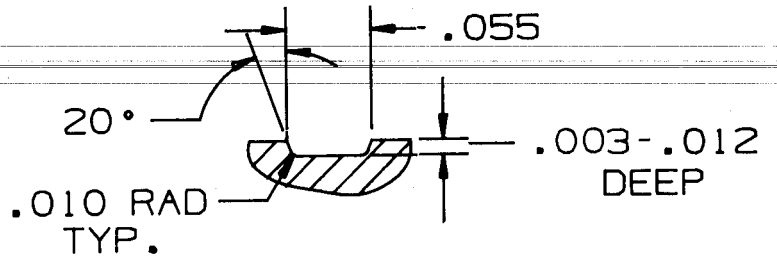

ALL CHARACTERS IN HELVETICA BOLD

SIZE OF SYMBOL	APPROXIMATE PRINTING POINT SIZE	
	NUMBERS	LETTERS
1/2"	13	9
3/4"	20	13
1"	26	17

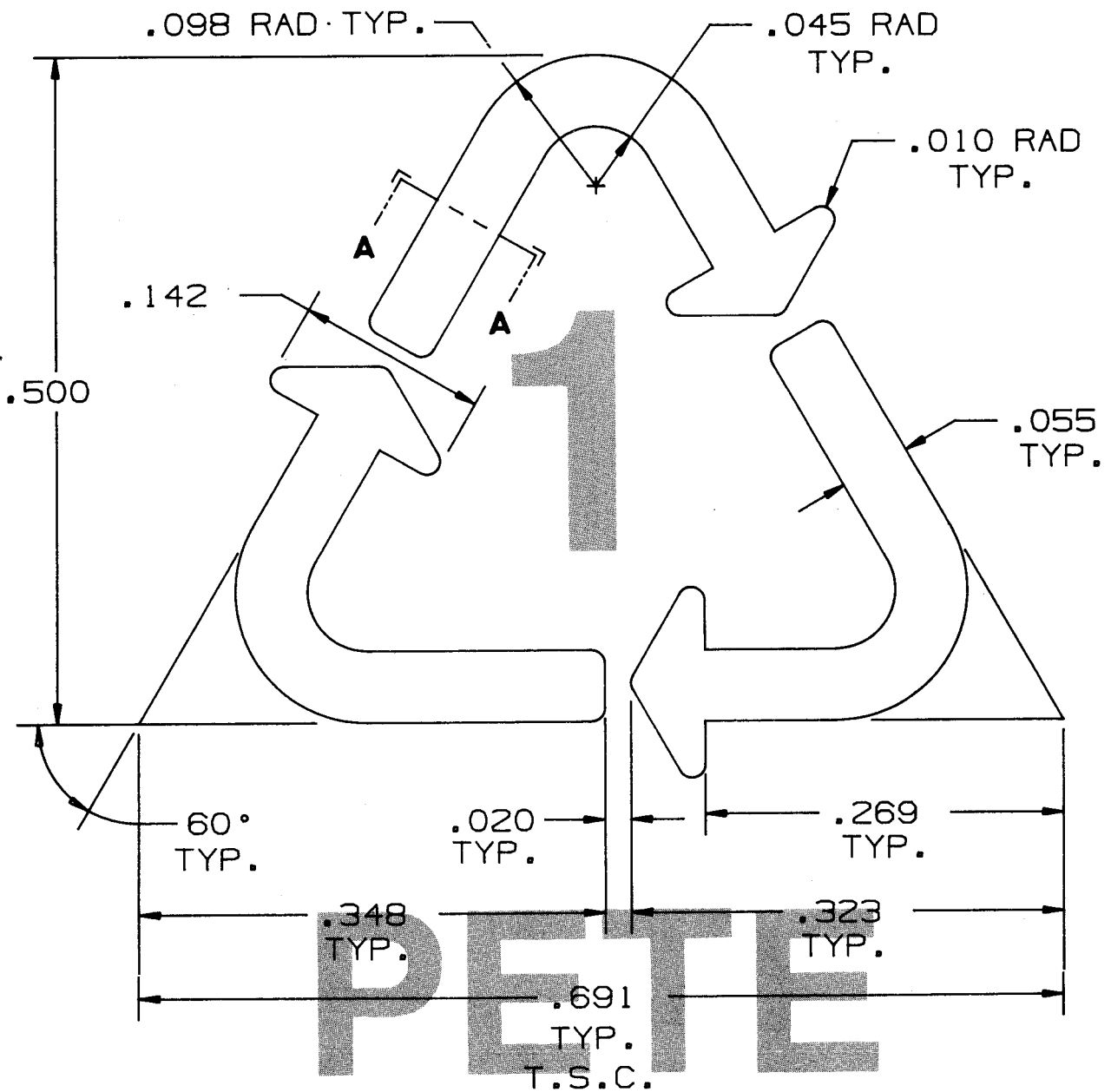

9.0 ENGRAVING MASTERS

9.2 Numbers & Letters

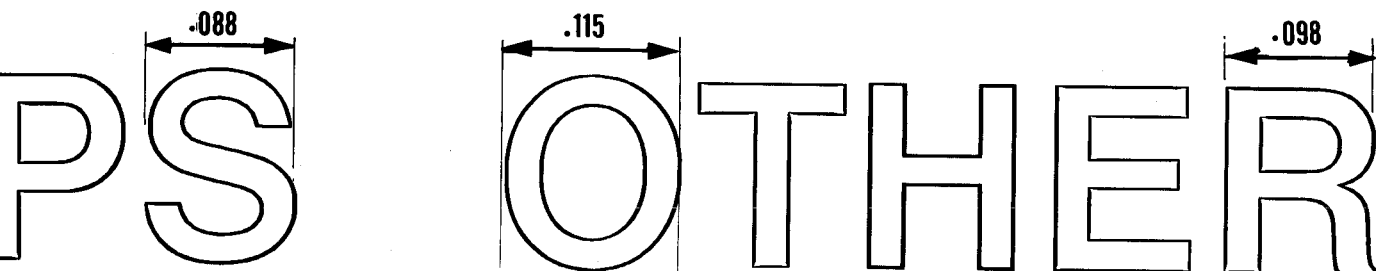
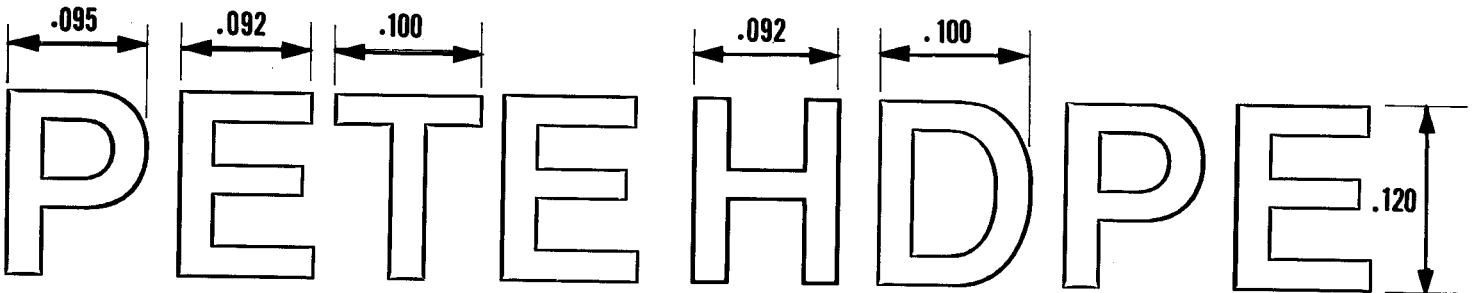
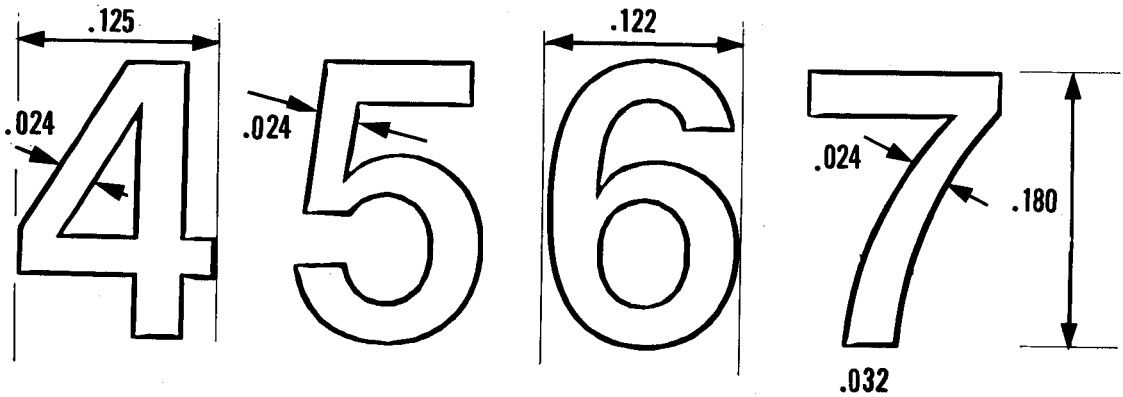
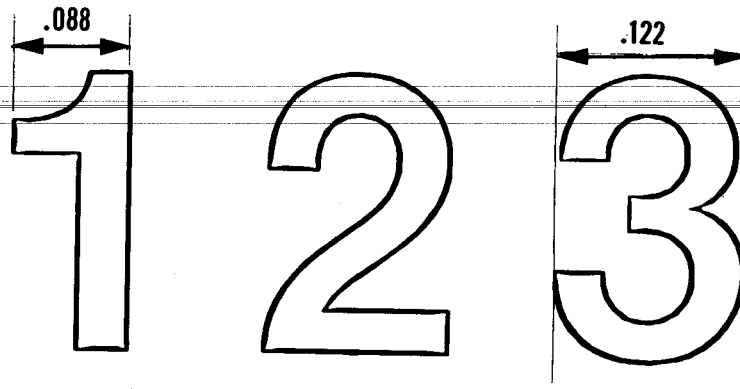

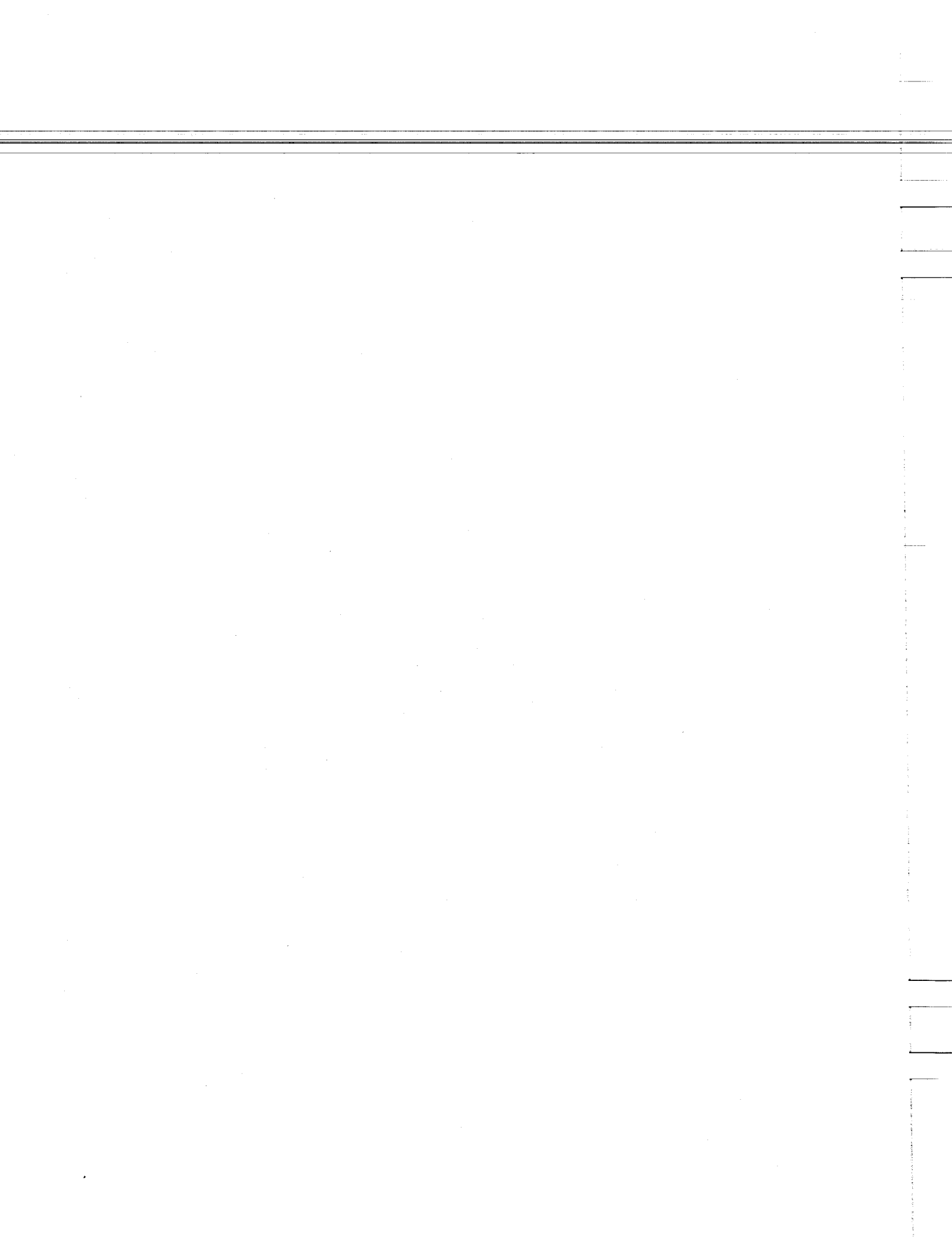





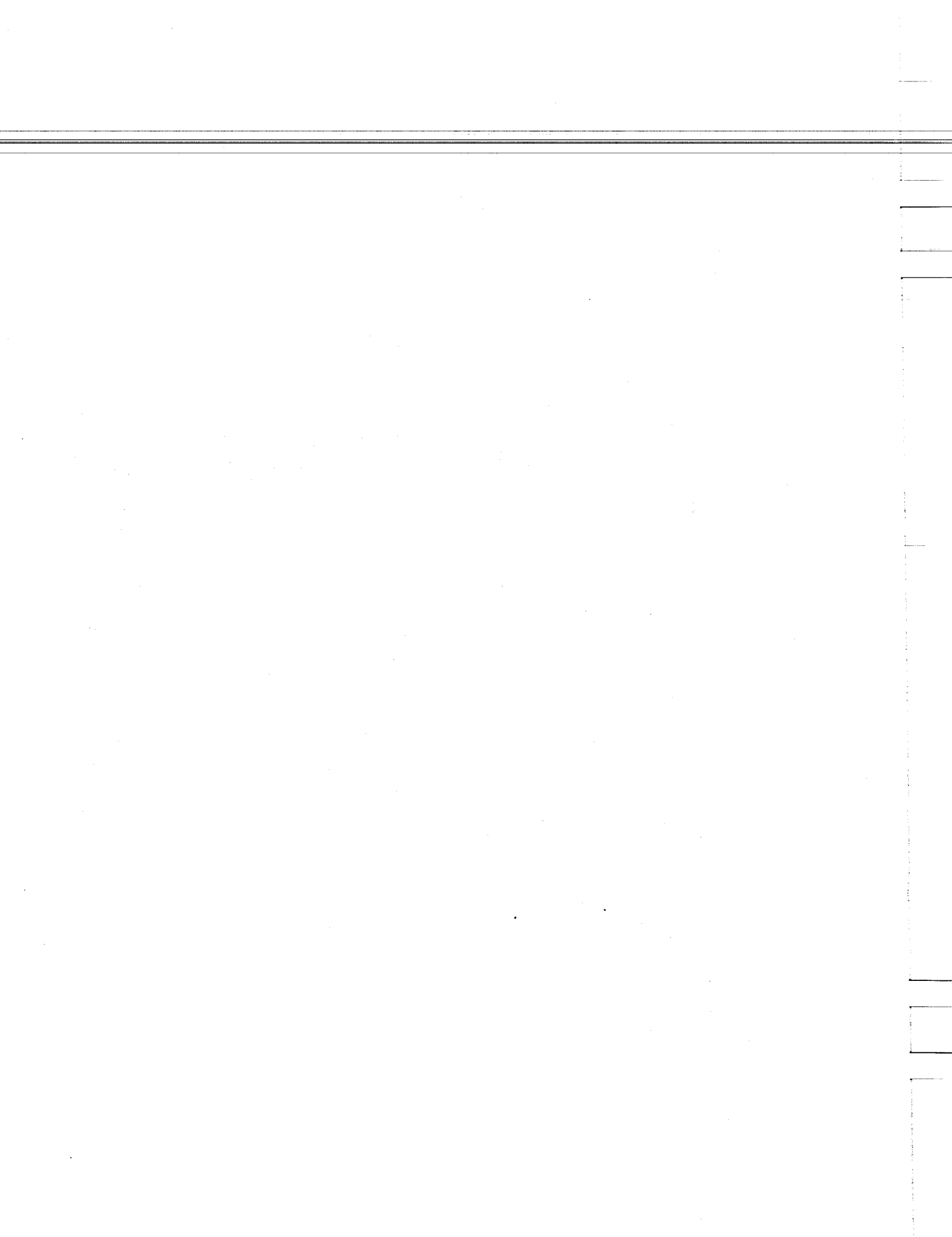

New England Region

Connecticut, Maine, Massachusetts,  
New Hampshire, New York, Rhode Island

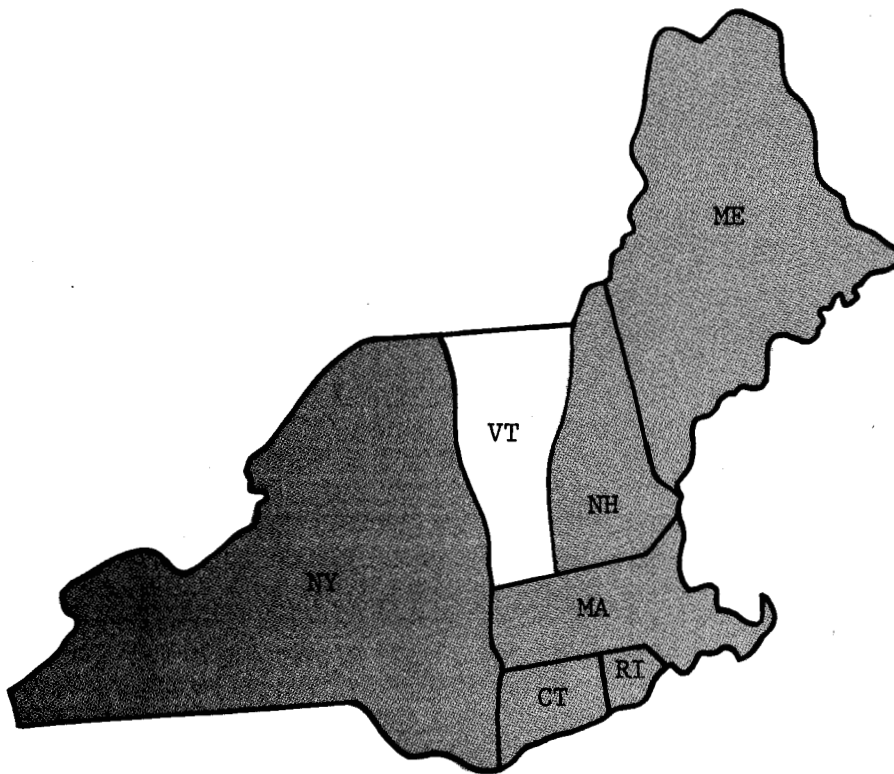

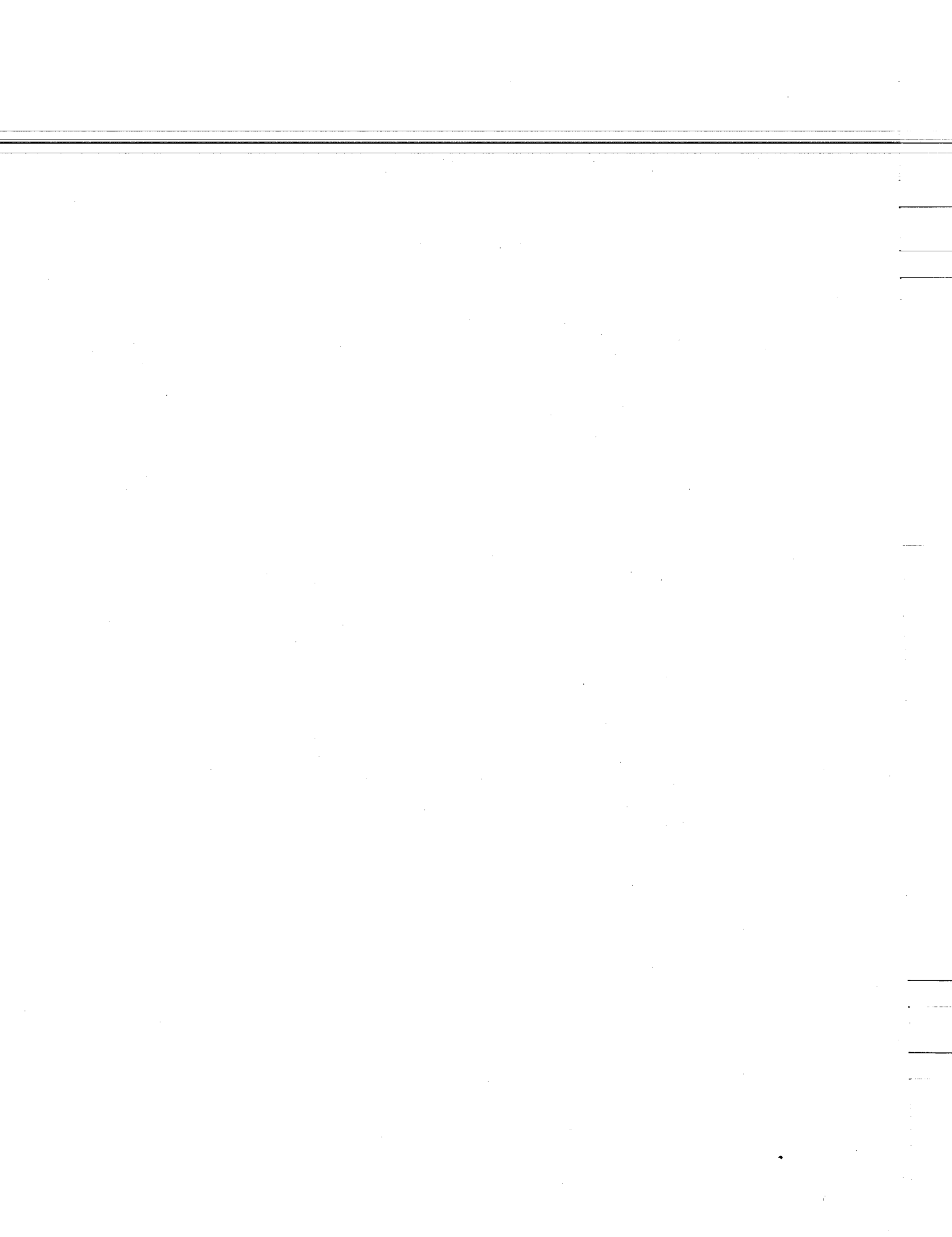

## CONNECTICUT

1. **Compliance Date:** January 1, 1990, except manufacturers of plastic containers are only required to comply "to the extent feasible."
2. **Scope:** Plastic containers composed primarily of one or more plastics (not limited to thermoplastics) sold or offered for sale in Connecticut in sizes greater than 16 ounces. Note: The law refers only to plastic bottles but does not define a bottle as having any particular shape.
3. **Required Codes:** The plastic material that is in the structure of the container must be identified.

**Note:** The Commissioner of Environmental Protection has adopted standards for identification codes. Regulations became effective November 30, 1989 (see summary below).

4. **Required Symbol:** None.
5. **Type and Location of Code:** Affixed to bottle or container. Location not specified.
6. **Penalties:** None Specified.
7. **Additional Information:**

Department of Environmental Protection  
165 Capitol Avenue  
Hartford, Connecticut 06106  
(203) 566-8722

8. **Attachment:** CONN. GEN. STAT. ANN. § 22a-255,  
October 1, 1988  
Regulations of Connecticut State  
Agencies  
§§ 22a-255b-1 to 22a-255b-3

**Summary of Connecticut Regulations**

**1. Required Codes:**

<u>Resin Type*</u>	<u>Code Number</u>	<u>Code Letters</u>
Polyethylene Terephthalate	1	PETE
High Density Polyethylene	2	HDPE
Polyvinyl Chloride	3	V
Low Density Polyethylene	4	LDPE
Polypropylene	5	PP
Polystyrene	6	PS
Other	7	OTHER

A. Section 22a-255b-3(a)(2) restricts the use of codes 1-6 and their corresponding acronyms to containers in which affixed materials and additives that are not within the resin type definition do not exceed 10%. The single resin definition for polyvinyl chloride is a "vinyl plastic." Accordingly, it would appear that the additives required to change a PVC resin into "vinyl plastic" should be considered as part of the single resin in determining compliance with the ten percent purity requirement since these additives are within the resin type definition for "polyvinyl chloride."

B. Base cups and labels: PET soft drink bottles with HDPE basecups shall be coded as PETE; otherwise, affixed materials are subject to ten percent purity requirement.

C. Multilayer: Include as "7-OTHER."

2. **Required Symbol:** "Code number may be placed within a triangular configuration of arrows"†

3. **Type and Location of Code:** Numbers and letters must be at least ¼ inch in height; seven letters per inch in width; code shall be located on the base of the container; designed to be readable at a glance and to withstand handling.

4. **Penalties:** None Specified.

\*/ Each resin is specifically defined by regulation. The term OTHER means (1) any other single resin or (2) any mixture of plastic resins or (3) any multiple layer plastic containing layers or barriers of a material other than the single resin.

† Denotes requirements that are consistent with the SPI Voluntary Code.

## ADMINISTRATIVE REGULATIONS

*Regulations and notices published herein, pursuant to General Statutes Section 4-168 and 4-173, are printed exactly as submitted by the forwarding agencies. These, being official documents submitted by the responsible agencies, are consequently not subject to editing by the Commission on Official Legal Publications.*

### DEPARTMENT OF ENVIRONMENTAL PROTECTION

#### Plastic Bottle Coding

Section 1: The Regulations of Connecticut State Agencies are amended by addition of the new sections 22a-255b-1 to 22a-255b-3, inclusive, as follows:

##### Sec. 22a-255b-1. Definitions

As used in sections 22a-255b-1 to 22a-255b-3, inclusive:

"High density polyethylene" means a rigid plastic material of polyethylenes with a density of 0.94 grams per cubic centimeter or greater.

"Low density polyethylene" means polyethylenes with a density of less than 0.94 grams per cubic centimeter.

"Other" means a plastic bottle consisting of a single resin other than polyethylene terephthalate, high density polyethylene, polyvinyl chloride, low density polyethylene, polypropylene, or polystyrene; or a plastic bottle consisting of a mixture of plastic resins; or a plastic bottle consisting of multiple layers of plastic resins with adhesives or barriers of a material other than the single plastic resin material in the layers; or a plastic bottle with an affixed structure other than the closure and label which consists of a different material than the plastic bottle itself.

"Plastic bottle" means a container, exclusive of closure, with a capacity of sixteen ounces or more composed primarily of one or more plastics.

"Polyethylene terephthalate" means a saturated, thermoplastic polyester resin.

"Polypropylene" means a thermoplastic resin made by polymerizing propylene with catalysts.

"Polystyrene" means polymers of styrene.

"Polyvinyl chloride" means a vinyl plastic.

##### Sec. 22a-255b-2. Design

(a) Code numbers and acronyms shall be designed to facilitate reading at a glance, to withstand container handling, and to be compatible with processing systems. The code number and acronym shall be located on the base of the plastic bottle. Each code number and acronym letter shall be at least one quarter of an inch in height and at a scale of seven letters per inch in width.

(b) The code numbers and acronyms shall be as follows:

(1) For polyethylene terephthalate: the acronym "PETE" and the number "1."

(2) For high density polyethylene: the acronym "HDPE" and the number "2."

- (3) For polyvinyl chloride: the acronym "V" and the number "3."
- (4) For low density polyethylene: the acronym "LDPE" and the number "4."
- (5) For polypropylene: the acronym "PP" and the number "5."
- (6) For polystyrene: the acronym "PS" and the number "6."
- (7) For other: the acronym "OTHER" and the number "7."
- (c) The code number may be placed within a triangular configuration of arrows on a plastic bottle.

#### **Sec. 22a-255b-3. Application**

(a) Effective upon the date mandated by Section 22a-255b of the Connecticut General Statutes, any plastic bottle sold or offered for sale in Connecticut shall have imprinted or molded on its base a code number and acronym as identified in Section 22a-255b-2 of the Regulations of Connecticut State Agencies. The code number and acronym applied to any plastic bottle shall be subject to verification upon written request of the Commissioner and shall correctly identify the container material composition consistent with the definitions in Section 22a-255b-1 of the Regulations of Connecticut State Agencies with the following exceptions:

(1) Polyethylene terephthalate carbonated soft drink bottles with affixed high density polyethylene base cups shall utilize the acronym and code number in Subdivision 22a-255b-2 (b) (1) of the Regulations of Connecticut State Agencies; and

(2) Any plastic bottle where the affixed materials and additives other than the single plastic resin bottle structure exceed ten percent by weight of the total mass, shall be coded with the code number and acronym specified in Subdivision 22a-255b-2 (b) (7) of the Regulations of Connecticut State Agencies.

(b) Municipalities shall publicize the codes and acronyms in the context of their recycling program public education efforts.

**Statement of purpose:** To establish standards for the coding of plastic bottles to facilitate recycling in accordance with section 22a-255b (b) of the Connecticut General Statutes.

Be it known that the foregoing regulations are adopted by the aforesaid agency pursuant to Sec. 22a-255b of the General Statutes, after publication in the Connecticut Law Journal on December 6, 1988, of the notice of the proposal to adopt such regulations, and the holding of an advertised public hearing on the 18th day of January, 1989.

Wherefore, the foregoing regulations are hereby adopted, effective when filed with the Secretary of the State.

In Witness Whereof: November 6, 1989; Lealie Carothers, Commissioner.

Approved by the Attorney General as to legal sufficiency in accordance with Sec. 4-169, as amended, General Statutes: November 7, 1989.

Approved by the Legislative Regulation Review Committee in accordance with Sec. 4-170, as amended, of the General Statutes: November 28, 1989.

Two certified copies received and filed, and one such copy forwarded to the Commission on Official Legal Publications in accordance with Sec. 4-172, as amended, of the General Statutes, Secretary of the State: November 30, 1989.



**§ 22a-250****ENVIRONMENTAL PROTECTION****Historical Note****Codification**

Section heading was changed to conform to Gen.St., Rev. to 1989.

**1985 Amendments**

1985, P.A. 85-446, § 5, in subsec. (b), deleted "or subsec. (d) of section 22a-249, shall be fined ten dollars for the first offense, and not more than one hundred dollars for each subsequent offense" following "subsec. (a) of this section" and inserted "shall have committed an infraction", and deleted the former second sentence, which provided: "In addition thereto, in the discretion of the court, such person may be directed to pick up and remove from any public place or any private property with prior permission of the legal owner upon which it is established by competent evidence that such person has deposited litter, any or all litter deposited thereon by anyone prior to the date of execution of sentence"; deleted former subsec. (c) which provided additional penalties for conviction of a second or subsequent violation of subsec. (a); and redesignated former subsec. (d) as subsec. (c).

Section 6 of 1985, P.A. 85-446 provided:

"This act shall take effect October 1, 1985, except that sections 1 to 4, inclusive, shall take effect October 1, 1986."

1985, P.A. 85-613, § 65, eff. from passage, July 10, 1985, in subsec. (b), in the first sentence, and in former subsec. (c), deleted a reference to § 22a-249, subsec. (d), following "this section".

**1987 Legislation**

1987, P.A. 87-531, § 4, in subsec. (a), substituted reference to "mobile manufactured home" park for "trailer" park; in subsec. (c), substituted the present second sentence for "Any person

who violates any provision of this subsection shall have committed an infraction"; and added subsec. (d), relating to penalties and remedies.

**1988 Amendments**

1988, P.A. 88-230, § 1(a), in subsec. (e), effected change of terms by providing that whenever "judicial district of Hartford-New Britain" or "judicial district of Hartford-New Britain at Hartford" is used or referred to in this section, it shall be deemed to mean or refer to the judicial district of Hartford on and after Sept. 1, 1991.

1988, P.A. 88-230, § 1(b), in subsec. (e), effected change of terms by providing that if "judicial district of Hartford-New Britain" or "judicial district of Hartford-New Britain at Hartford" is used or referred to in any public act of 1988, 1989, 1990, or 1991, or in any section of the general statutes amended in 1988, 1989, 1990, or 1991, it shall be deemed to mean or refer to the judicial district of Hartford on and after Sept. 1, 1991.

1988, P.A. 88-320, § 2, without incorporating changes made by 1988, P.A. 88-230, § 1(a), (b), in subsec. (b), substituted provisions by which a violation of subsec. (a) of this section shall be subject to a fine of not more than \$250, for provisions by which such violation shall be considered the commission of an infraction; in subsec. (c), inserted provisions defining the term "dump" as that set out in subd. (12) of § 22a-248, inserted reference to a licensed facility for dumping; added subsec. (d); former subsec. (d) redesignated (e), and as so redesignated, added reference to subsec. (d) of this section, and added provisions relating to the forfeiture and seizure of vehicles used in violation of subsec. (d) of this section.

**§ 22a-255. Definitions**

(a) As used in sections 22a-255a to 22a-255c, inclusive:

- (1) "Beverage" means beer or other malt beverages and mineral waters, soda water and carbonated soft drinks in liquid form and intended for human consumption;
- (2) "Plastic bottle" means a container with a capacity of sixteen ounces or more composed primarily of one or more plastics; and
- (3) "Closure" means a screw on or twist off cap used to close a container when such cap is not integral to the structure of the container.

(1988, P.A. 88-231, § 13, eff. Oct. 1, 1988.)

**§ 22a-255a. Sale of certain beverage containers prohibited**

No person shall sell or offer for sale any beverage container composed of one or more plastics if the basic structure of the container, exclusive of the closure, also includes aluminum or steel.

(1988, P.A. 88-231, § 14, eff. Oct. 1, 1988.)

**§ 22a-255b. Identification code. Regulations**

(a) On or after January 1, 1990, any plastic bottle sold or offered for sale in this state shall bear an identification code indicating the plastic material that is in the structure of the bottle.

(b) The commissioner of environmental protection shall establish by regulations adopted in accordance with chapter 54<sup>1</sup>, standards for the identification code and provisions for providing consumers with an explanation of the code. In adopting such regulations and to promote uniformity of coding and separation of plastic bottles by material for recycling, the commissioner shall consult with manufacturers of plastic bottles, officials with regulatory authority over plastics in other states and representatives of recyclers.

(c) On or after January 1, 1990, and to the extent feasible, each manufacturer of plastic bottles with a capacity of sixteen ounces or more sold or offered for sale in this state shall affix to each plastic bottle an identification code indicating the plastic material that is in the structure of the bottle.

(1988, P.A. 88-231, § 15, eff. Oct. 1, 1988.)

<sup>1</sup> Section 4-166 et seq.

§ 22a-255c. Symbols indicating packaging is recyclable or made of recycled material

The commissioner of environmental protection may require that symbols be placed on packages sold or offered for sale in the state indicating the packaging is recyclable or made of recycled material when uniform symbols are approved by the states of Maine, New Hampshire, Vermont, Massachusetts and Rhode Island.

(1988, P.A. 88-231, § 16, eff. Oct. 1, 1988.)

## CHAPTER 446e

### SOLID WASTE MANAGEMENT SERVICES ACT

#### Section

22a-268a. Written procedures.  
22a-283. Disposal of waste from municipal or private waste-to-energy plant.

#### Section

22a-284. Agreement for administration of waste management project.

#### WESTLAW Electronic Research

See WESTLAW Electronic Research Guide following the Preface.

§ 22a-257. Short title

#### Cross References

Administration of waste management projects by municipalities, see § 22a-284.

§ 22a-260. Definitions

The following terms, as used in this chapter and chapter 103b,<sup>1</sup> shall have the indicated meanings unless the context in which they are used demands a different meaning and intent:

(1) "Authority" means the Connecticut resources recovery authority created and established pursuant to this chapter or any board, body, commission, department, officer, agency or other successor thereto;

(2) "State solid waste management plan" means the administrative and financial plan developed by the commissioner of environmental protection for solid waste disposal and resources recovery, pursuant to section 22a-211;

(3) "Resources recovery" means the processing of solid wastes in such a way as to produce materials or energy which may be used in manufacturing, agriculture, or other processes;

**MAINE**

1. **Compliance Date:** July 1, 1991
2. **Scope:** Plastic bottles and plastic containers (not limited to thermoplastics) distributed, sold, or offered for sale in Maine:

<u>Type</u>	<u>Size</u>
<u>Plastic Bottles</u> -- Container with neck smaller than its body and accepts a closure.	16 ounces to 5 gallons †
<u>Rigid Plastic Containers</u> -- Other than a plastic bottle, that retains the same shape when filled or empty.	8 ounces to 5 gallons †

3. **Required Codes:**

<u>Resin Type</u>	<u>Code Number</u> †	<u>Code Letters</u> †
Polyethylene Terephthalate	1	PETE
High Density Polyethylene	2	HDPE
Vinyl	3	V
Low Density Polyethylene	4	LDPE
Polypropylene	5	PP
Polystyrene	6	PS
Other	7	OTHER

- A. Base cups and labels: No provision. †
- B. Multilayer: Include as "7-OTHER."

4. **Required Symbol:** None: No label may include a chasing arrow or any other configuration of arrows to indicate recyclable materials or products with recycled content.\*

---

\*/ This provision has a conditional effective date; it does not become effective unless the Attorney General certifies, prior to January 1, 1991, that 6 of the following states have also banned  
(continued...)

† Denotes requirements that are consistent with the SPI Voluntary Code

5. **Required Location of Symbol:** Molded, imprinted or raised symbol on or near the bottom of the bottle or container.
6. **Penalties:** A violation shall be punishable by a civil penalty of not more than \$100; each container in violation constitutes a separate offense. Enforced by the Maine Waste Management Agency, Office of Waste Reduction and Recycling.

7. **Additional Information**

Ms. B. J. Jones  
Department of Economic and  
Community Development  
Office of Waste Reduction and  
Recycling  
Statehouse Station 130  
Augusta, Maine 04333  
(207) 289-6800

8. **Attachment:** Sec. 16.32 MRSA c.26 §1721, July 12, 1989

---

\*/(...continued)

such symbols: New Hampshire, Vermont, Massachusetts, Rhode Island, Connecticut, New York, New Jersey, Pennsylvania and Delaware. None of the listed states have banned such symbols. Furthermore, because the RIS is not meant to imply that the coded product will be recycled or contains recycled materials, this provision might not have had any bearing on the use of the RIS.

B. Ensure, to the maximum extent economically feasible, that it purchases goods, supplies, equipment, materials and printing that may be recycled or reused when such goods, supplies, equipment, materials and printing are discarded.

2. Preferences for recycled goods. In revising its procurement procedures and specifications under subsection 1, each municipality may:

A. Establish a preference for paper with recycled content consistent with the standards established for state agencies under Title 5, section 1812-B; and

B. Establish specifications for bids for public contracts that require all bidders to propose that a stated minimum percentage of goods, supplies, equipment or materials to be used for the contract be made from recycled material.

3. Other laws. The options set forth in this section may be exercised, notwithstanding any other provision of law to the contrary.

4. Interlocal cooperation. The provisions of this section shall apply to agreements of interlocal cooperation established pursuant to chapter 115 and to cooperative purchasing programs administered by regional councils established pursuant to chapter 119.

Sec. 16. 32 MRSA c. 26 is enacted to read:

#### CHAPTER 26

#### CODING OF PLASTIC CONTAINERS

#### §1721. Definitions

As used in this chapter, unless the context otherwise indicates, the following terms have the following meanings.

1. Plastic bottle. "Plastic bottle" means any plastic container with a neck smaller than the container body and a capacity not less than 16 fluid ounces and not more than 5 gallons.

2. Plastic container. "Plastic container" means any bottle, can, jar, case, package or other receptacle intended to hold, carry, or enclose fluids, food items or nonfood products that is composed predominately of plastic resins, including, but not limited to, plastic resins listed in section 1723.

3. Rigid plastic container. "Rigid plastic container" means any formed or molded plastic container, except plastic bottles, with a capacity not less than 8 fluid ounces and not more than 5 gallons that retains the same shape whether full or empty.

§1722. Coding of plastic containers

On or after July 1, 1991, no person may distribute, sell or offer for sale any plastic bottle or rigid plastic container without a molded, imprinted or raised label indicating the type of plastic resin used to produce the plastic bottle or rigid plastic container.

§1723. Labels

1. Labels. The label shall appear on the bottom of the plastic bottle or rigid plastic container and be clearly visible. This label shall consist of a number with letters placed below the number. The numbers and letters shall be as follows:

A. For polyethylene terephthalate, the letters "PETE" and the number 1;

B. For high-density polyethylene, the letters "HDPE" and the number 2;

C. For vinyl, the letter "V" and the number 3;

D. For low-density polyethylene, the letters "LDPE" and the number 4;

E. For polypropylene, the letters "PP" and the number 5;

F. For polystyrene, the letters "PS" and the number 6; or

G. For any other plastic resins, including multilayer, the letters "OTHER" and the number 7.

§1724. Ancillary symbols

No label may include a chasing arrow symbol or any other configuration of arrows to indicate recyclable materials or products with recycled content.

§1725. Penalties

1. Civil violation. A violation of this chapter shall be a civil violation for which a forfeiture of not more than \$100 may be adjudged.

2. Separate violation. Each container in violation constitutes a separate offense.

§1726. Rules and enforcement

The Maine Waste Management Agency, Office of Waste Reduction and Recycling shall adopt and enforce rules implementing the provisions of this chapter including, but not limited to, criteria for labeling containers made of more than one plastic resin. In adopting rules, the office shall consult with the Waste Management Advisory Council, the Department of Agriculture, Food and Rural Resources, plastic container manufacturers and distributors, and the recycling industry. Rules shall be adopted in accordance with the provisions of Title 5, chapter 375.

Sec. 17.36 MRSA §5219-C is enacted to read:

§5219-C. Solid waste reduction investment tax credit

1. Definitions. As used in this section, unless the contents otherwise indicates, the following terms have the following meanings.

A. "Employing unit" has the same meaning as in Title 26, section 1043.

B. "Solid waste" has the same meaning as in Title 38, section 1303-C.

C. "Waste reduction, reuse or recycling equipment" means structures, machinery or devices, singly or in combination, designed and required to separate, process, modify, convert, treat or repair solid waste generated by the employing unit so that component materials or substances or recoverable resources may be used as a raw material or for productive use and includes:

(1) Add-ons or trailers designed to modify collection vehicles and dedicated to sorting and separating of collected wastes generated by the employing unit and held for the purpose of recycling; or

(2) Containers for the source separation and temporary storage of recyclable wastes by the employing unit or its employees.

2. Credit allowed. A taxpayer constituting an employing unit who purchases waste reduction, reuse or recycling equipment, or other equipment used exclusively by that unit, in the implementation of a solid waste reduction, reuse or recycling program, shall be entitled to a credit against the tax imposed by this Part equal to 30% of the cost of the machinery or equipment.

additive to asphalt concrete, which would utilize waste tires. The report shall include, but shall not be limited to, the following:

A. Evaluating how effective the use of ground tire rubber has been in providing acceptable properties in asphalt concrete mix;

B. Determining effects and procedures for recycling asphalt containing ground tire rubber;

C. Determining the amount of ground tire rubber that may be used in road construction and the expected cost of that use;

D. Identifying changes needed in departmental and local government specifications and procedures to allow for the use of ground tire rubber from waste tires in asphalt concrete pavements; and

E. In conjunction with the Department of Environmental Protection and the Office of Waste Reduction and Recycling, the inventory of discarded tires in the State.

3. All state agencies shall cooperate with the Department of Transportation in carrying out this section.

Sec. 19. Conditional effective date. Title 32, section 1724, shall become effective if the Attorney General certifies, prior to January 1, 1991, that 6 of the states listed below have banned the use of ancillary symbols, described in Title 32, section 1724, in labels on rigid plastic containers. The states are: New Hampshire, Vermont, Massachusetts, Rhode Island, Connecticut, New York, New Jersey, Pennsylvania and Delaware.

#### PART D

Sec. 1. 28-A MRSA §1651, sub-§1, ¶C is enacted to read:

C. The commission shall add any cost to the State, related to handling containers returned for refund pursuant to Title 32, section 1863, to the established price without markup.

Sec. 2. 32 MRSA §1862, sub-§1, as amended by PL 1987, c. 649, §1, is repealed and the following enacted in its place:

1. Beverage. "Beverage" means beer, ale or other drink produced by fermenting malt, spirits, wine, wine coolers, soda or noncarbonated water, and all nonalcoholic carbonated or noncarbonated drinks in liquid form and intended for internal human consumption, except for milk and dairy-derived products.



## MASSACHUSETTS

1. **Compliance Date:** July 1, 1991
2. **Scope:** All plastic bottles and containers that can be shaped by flow distributed, sold or offered for sale in Massachusetts unless exempted by regulation.\* /

<u>Type</u>	<u>Size</u>
<u>Plastic Bottles</u> -- Container with neck smaller than its body and accepts a closure.	16 ounces to 5 gallons †
<u>Rigid Plastic Containers</u> -- Other than bottle; intended for single use; inflexible finite shape.	8 ounces to 5 gallons †

### 3. Required Codes:

<u>Resin Type</u>	<u>Code Number</u> †	<u>Code Letters</u> †
Polyethylene Terephthalate	1	PETE
High Density Polyethylene	2	HDPE
Vinyl	3	V
Low Density Polyethylene	4	LDPE
Polypropylene	5	PP
Polystyrene	6	PS
Other	7	OTHER

---

\* / The Division of Solid Waste Management is authorized to promulgate regulations that exempt certain containers, including but not limited to: (1) readily identifiable plastic bottles and rigid plastic containers; (2) plastic bottles and rigid plastic containers for which there is no technological capability for recycling, reclamation or reuse; and (3) plastic bottles and rigid plastic containers for which recycling, reclamation or reuse is not economically feasible.

† Denotes requirements that are consistent with the SPI Voluntary Code

- A. Base cups and labels: Plastic bottles or rigid plastic containers with labels and base cups of a different material shall be coded by their basic material. †
- B. Multilayer: Include as "7-OTHER."
4. **Required Symbol**: RIS; Size not specified. †
5. **Type and Location of Code**: Molded imprint or raised symbol on or near the bottom of the bottle or container.
6. **Penalties**: None specified.
7. **Additional Information**:
- Department of Environmental Protection  
Division of Solid Waste Management  
One Winter St.  
4th floor  
Boston, Massachusetts 02108  
Michael H. King, Recycling Director  
(617) 292-5961
8. **Attachment**: MASS. GEN. L. ch. 94 §321 (1989), June 21, 1989

† Denotes requirements that are consistent with the SPI Voluntary Code

## THE COMMONWEALTH OF MASSACHUSETTS

*In the Year One Thousand Nine Hundred and Eighty-nine*

**AN ACT RELATIVE TO LABELING OF PLASTIC BOTTLES AND CONTAINERS.**

*Be it enacted by the Senate and House of Representatives in General Court assembled, and by the authority of the same, as follows:*

**SECTION 1.** Section 321 of chapter 94 of the General Laws, as appearing in the 1986 Official Edition, is hereby amended by inserting after the definition of "Distributor" the following four definitions:-

"Label", a molded imprint or raised symbol on or near the bottom of a plastic product.

"Plastic", any material made of polymeric organic compounds and additives that can be shaped by flow.

"Plastic bottle", a plastic container that has a neck that is smaller than the body of the container, accepts a screwtype, snap cap or other closure and has a capacity of sixteen fluid ounces or more, but less than five gallons.

"Rigid plastic container", any formed or molded container, other than a bottle, intended for single use, composed predominantly of plastic resin and having a relatively inflexible finite shape or form with a capacity of eight ounces or more but less than five gallons.

**SECTION 2.** Said chapter 94 is hereby further amended by inserting after section 323, as so appearing, the following section:-

Section 323A. No person shall distribute, sell or offer for sale any plastic bottle or rigid plastic container, or any product in such a bottle or container, unless such product bottle or container is labeled with a code indicating the plastic resin used to produce the bottle or container. Plastic bottles or rigid plastic containers with labels and basecaps of a different material shall be coded by their basic material. Such code shall consist of a number placed within a triangle of arrows and letters placed below the triangle of arrows. The triangle shall be equilateral, formed by three arrows with the apex of each point of the triangle at the midpoint of each arrow, rounded with a short radius. The arrowhead of each arrow shall be at the midpoint of each side of the triangle with a short gap separating the pointer from the

base of the adjacent arrow. The triangle, formed by the three arrows curved at their midpoints shall depict a clockwise path around the code number. The numbers and letters used shall be as follows:

- (a) "1" - PETE (polyethylene terephthalate);
- (b) "2" - HDPE (high density polyethylene);
- (c) "3" - V (vinyl);
- (d) "4" - LDPE (low density polyethylene);
- (e) "5" - PP (polypropylene)
- (f) "6" - PS (polystyrene);
- (g) "7" - OTHER (includes multi-layer).

SECTION 3. Section 326 of said chapter 94, as so appearing, is hereby amended by adding the following paragraph:-

Said secretary shall determine through rules and regulations which plastic bottles and rigid plastic containers may be exempt from the labeling requirements of section three hundred and twenty-three A, including but not limited to the following:

- (1) readily identifiable plastic bottles and rigid plastic containers;
- (2) plastic bottles and rigid plastic containers for which there is no technological capability for recycling, reclamation or reuse; and
- (3) plastic bottles and rigid plastic containers for which recycling, reclamation or reuse is not economically feasible.

SECTION 4. The provisions of this act shall take effect on July first, nineteen hundred and ninety-one.

House of Representatives, June 7, 1989.

Passed to be enacted,

*George Lererian*, Speaker.

In Senate, June 8, 1989.

Passed to be enacted,

*William W. Burgess*, President.

June 21, 1989.

Approved.

*Richard D. Hughes*, Governor.

## \* NEW HAMPSHIRE

New Hampshire has not enacted a plastic container coding law like the others presented in this manual. Instead, New Hampshire has adopted "An Act Relative to a Recycling Logo," which requires New Hampshire's Department of Environmental Services to establish a recycle logo which may be used on recycled or recyclable containers. The law explicitly provides that standards to be adopted under the law shall not interfere with the use of SPI's resin identification symbol.

**Attachment:** N.H. Rev. Stat. Ann. § 149-N (1989)  
(HB 605-N attached)

HOUSE BILL AMENDED BY THE SENATE

- 1 -

Chapter 318

1268B  
89-0758  
04  
2713B

HB 605-FN

STATE OF NEW HAMPSHIRE

In the year of Our Lord one thousand  
nine hundred and eighty-nine

AN ACT

relative to a recycling logo.

Be it Enacted by the Senate and House of Represen-  
tatives in General Court convened:

318: 1 New Chapter; Recycling. Amend RSA by inserting after chapter 149-M  
the following new chapter:

CHAPTER 149-N

RECYCLING LOGO

149-N:1 Recycling Logo Established. The department of environmental  
services shall establish the international 3 arrow recycling emblem with a  
designation of whether the item on which it is placed is recycled or  
recyclable material. This emblem shall be the exclusive symbol for use on  
material which is authorized to be so labeled under this chapter.

149-N:2 Definitions. In this chapter:

I. "Recyclable material" means any material which is identified as  
recyclable material by the department of environmental services in  
accordance with rules adopted by the commissioner of environmental

HOUSE BILL AMENDED BY THE SENATE

- 2 -

services. It shall include, but not be limited to, glass, food, and beverage containers, plastic milk containers, plastic soft drink containers, newspaper, tin coated steel cans and steel cans, aluminum, corrugated cardboard, and mixed office paper.

II. "Recycled material" means any material which is produced of material with at least 50 percent post-consumer material.

III. "Post-consumer material" means only those products generated by either a commercial entity or consumer which have served their intended end uses and which have been separated; or diverted from solid waste for the purposes of collection, recycling, and disposition.

149-N:3 Logo Use Restricted. Unauthorized use of or use of the logo contrary to the rules adopted pursuant to this section shall constitute an unfair and deceptive trade practice within the meaning of RSA 358-A:2. Any right or remedy set forth in RSA 358-A may be used to enforce the provision of this chapter.

149-N:4 Rulemaking Authority.

I. The commissioner of environmental services shall adopt rules, under RSA 541-A, which establish:

(a) Standards to be met to qualify products as composed of recycled or recyclable materials. These standards shall not interfere or prohibit the placement of the uniform plastic resin content code for plastic bottles and containers of the Society of the Plastics Industry, Inc. (SPI) on materials covered by this chapter.

(b) Requirements to be met for display of the logo on products.

II. The standards and requirements adopted under this section shall

HOUSE BILL AMENDED BY THE SENATE

- 3 -

coordinate with those of the Northeast Recycling Council of the Council of State Governments, and coordinate with those standards and requirements developed by all the northeastern states, when possible.

318: 2 Effective Date. This act shall take effect 60 days after its passage.

*Approved May 29, 1989*  
*Effective July 28, 1989*



---

**\* NEW YORK**

New York has not enacted a plastic container coding law like the others presented in this manual. Instead, New York has adopted a broader law to promote recycling of solid waste. That law directs New York's Bureau of Waste Reduction and Recycling to establish a recycle log which may be used on recycled or recyclable containers that meet applicable criteria.

**Attachment:** N.Y. CLS ECL § 27-0717

## ENVIRONMENTAL CONSERVATION LAW

**§ 27-0717. Bureau of waste reduction and recycling**

1. The commissioner, with the approval of the director of the division of the budget, shall establish within the department a bureau of waste reduction and recycling. Such bureau shall be a separate entity to assist in the development and promotion of local waste reduction, source separation and recycling programs. Such programs shall promote the source separation, collection, intermediate processing and marketing of waste materials that are now being disposed of as municipal solid waste in New York state. The bureau shall:

- (a) promote the development and implementation of programs by municipalities;
- (b) serve as a clearinghouse for information regarding existing source separation and recycling programs;
- (c) identify special needs and problems in developing and implementing source separation and recycling programs, and recommend approaches and solutions to address such identified needs and problems; and
- (d) coordinate its activities with other solid waste assistance programs of the department.

2. Pursuant to regulations promulgated in accordance with the state administrative procedure act, the bureau shall establish an official state recycling emblem and conduct a consumer awareness program with respect thereto. Such emblem shall be of a design to include terms or symbols for "New York State", and "recyclable" and/or "recycled" and/or "reusable". Standards for such terms or symbols shall be developed pursuant to regulations which with respect to (a) "recyclable" shall address material for which technologies or systems for reuse as a secondary material exist; and (b) "recycled" shall address material containing a specified minimum percentage by weight of secondary materials content; and (c) "reusable" shall address ability to be repeatedly returned for refilling or reuse with the original product. Further, such regulations may stipulate prohibitions on the unauthorized use of the state recycling emblem.

3. The bureau shall implement and conduct a program of public education and information to inform the public and private sectors of the state as to the merits of the use of secondary materials and for consumers to actively seek consumer products which contain secondary materials or which are easily recycled or reused. Such program shall communicate the importance of minimizing the need for new solid waste disposal capacity and of conserving natural resources, avoiding harm to the environment or public health, and promoting resource conservation, recovery and reuse by industry, the state of New York, public and quasi-public agencies and authorities, local governments and the general public of the state.

4. The bureau shall be responsible for the administration of the New York state local resource reuse and development program established pursuant to sections 27-0403 and 27-0405 of this article.

(Added L.1988, c. 70, § 13.)

**Effective Date: Rules and Regulations.** Section eff. May 2, 1988, provided rules and regulations necessary for implementation are completed on or before Jan. 1, 1989, pursuant to section 29

of L.1988, c. 70, set out as a note under section 27-0106.

**Separability of Provisions.** See section 28 of L.1988, c. 70, set out as a note under section 27-0106.

## RHODE ISLAND

1. **Compliance Date:** January 1, 1991
2. **Scope:** Plastic containers distributed, sold, or offered for sale in Rhode Island:

<u>Type</u>	<u>Size</u>
<p><u>Rigid Plastic Containers</u> -- Formed or molded container, intended for single use, composed predominantly of plastic resin, relatively inflexible, finite shape.</p>	8 ounces to 5 gallons †
<p><u>Plastic Bottles</u> -- Container with a neck smaller than its body; accepts a screw-type, snap-cap, or other closure.</p>	16 ounces to 5 gallons †

3. **Required Codes:**

<u>Resin Type</u>	<u>Code Number</u> †	<u>Code Letters</u> †
Polyethylene Terephthalate	1	PETE
High Density Polyethylene	2	HDPE
Vinyl	3	V
Low Density Polyethylene	4	LDPE
Polypropylene	5	PP
Polystyrene	6	PS
Other	7	OTHER

- A. Base cups and labels: Containers with labels and basecups shall be coded by their basic material. †
- B. Multilayer: No provision.

4. **Required Symbol:** RIS; size not specified.
5. **Type and Location of Symbol:** Molded imprint or raised symbol on the bottom of a plastic product unless the manufacturer demonstrates the reasonable necessity for an alternative location, in which case, it shall be near the product bottom.

† Denotes requirements that are consistent with the SPI Voluntary Code

6. **Penalties:** No provision.

7. **Additional Information:**

Ms. Jan Aceti  
Department of Environmental Management  
Office of Environmental Coordination  
83 Park Street  
Providence, Rhode Island 02903  
(401) 277-3434

8. **Attachments:** R.I. Gen. Laws § 23-18.15-1 et seq.

† Denotes requirements that are consistent with the SPI Voluntary Code



**1990**  
**POCKET SUPPLEMENT**

**GENERAL LAWS**  
**OF**  
**RHODE ISLAND, 1956**

**Reenactment of 1989**

**VOLUME 4B**

**The General Laws of 1956 as Enacted by the General Assembly at the  
January Session, 1957, chapter 34, Revised Public Laws of 1957,  
as amended through the January Session, 1990, of the  
Rhode Island General Assembly**

**Place this supplement in the pocket of the corresponding  
volume of the set**



**THE MICHIE COMPANY**  
*Law Publishers*  
**CHARLOTTESVILLE, VIRGINIA**

**History of Section.**

P.L. 1990, ch. 397, § 1.

**23-18.14-5. Enforcement.** — (a) The director or his or her duly authorized agent is authorized to assess administrative penalties for violations of this chapter, in accordance with the provisions of chapter 17.6 of title 42.

(b) In addition to any administrative penalty, the director may institute a civil action in the name of the state, in a court of competent jurisdiction, for injunctive relief, to enjoin and restrain violations of this chapter.

**History of Section.**

P.L. 1990, ch. 397, § 1.

**23-18.14-6. Severability.** — If any part or provision of this chapter or the application thereof to any person, entity, or circumstances be judged invalid by any court of competent jurisdiction, such judgment shall be confined in its operation to the part of or provision of or application directly involved in the controversy in which such judgment has been rendered and shall not affect or impair the validity of the remainder of this law or the application thereof to other persons, entities, or circumstances.

**History of Section.**

P.L. 1990, ch. 397, § 1.

## CHAPTER 18.15

## PLASTIC BOTTLE AND CONTAINER LABELING ACT

[Effective January 1, 1991]

**SECTION.**

23-18.15-1. Definitions.

23-18.15-2. Labeling requirements.

**SECTION.**

23-18.15-3. Regulations.

**Compiler's Notes.** As enacted by P.L. 1990, ch. 270, § 1, this chapter was designated as chapter 18.13 of title 23. Inasmuch as P.L. 1990, ch. 149, § 1 also enacted a chapter designated as chapter 18.13, and, inasmuch as P.L. 1990, ch. 397, § 1 already enacted a chapter designated as chapter 18.14, this chapter was redesignated as chapter

18.15 by the law revision officer of the joint committee on legislative services pursuant to § 43-2-2.1.

**Delayed Effective Dates.** Section 2 of P.L. 1990, ch. 270 provides that the enactment of this chapter by that Act shall take effect January 1, 1991.

**23-18.15-1. Definitions.** [Effective January 1, 1991.] — As used in this chapter:

(a) "Label" means a molded imprint or raised symbol on the bottom of a plastic product, unless the manufacturer demonstrates the reasonable necessity for an alternate location, in which case it shall be near the product bottom.

(b) "Plastic" means any material made of polymeric organic compounds and additives that can be shaped by flow.

(c) "Plastic bottle" means a plastic container that has a neck that is smaller than the body of the container, accepts a screwtype, snap cap or other closure and has a capacity of sixteen (16) fluid ounces or more, but less than five (5) gallons.

(d) "Rigid plastic container" means any formed or molded container, other than a bottle, intended for single use, composed predominantly of plastic resin and having a relatively inflexible finite shape or form with a capacity of eight (8) ounces or more but less than five (5) gallons.

**History of Section.**

P.L. 1990, ch. 270, § 1.

**Delayed Effective Dates.** For the delayed

effective date of this section see the note under this same heading following the chapter analysis.

**23-18.15-2. Labeling requirements.** [Effective January 1, 1991.] — No person shall distribute, sell or offer for sale any plastic bottle or rigid plastic container, or any product in such a bottle or container, unless such product bottle or container is labeled with a code indicating the plastic resin used to produce the bottle or container. Plastic bottles or rigid plastic containers with labels and basecups of a different material shall be coded by their basic material. Such code shall consist of a number placed within a triangle of arrows and letters placed below the triangle of arrows. The triangle shall be equilateral, formed by three arrows with the apex of each point of the triangle at the midpoint of each arrow, rounded with a short radius. The arrowhead of each arrow shall be at the midpoint of each side of the triangle with a short gap separating the pointer from the base of the adjacent arrow. The triangle, formed by the three arrows curved at their midpoints shall depict a clockwise path around the code number. The numbers and letters used shall be as follows:

- (a) "1" — PETE (polyethylene terephthalate);
- (b) "2" — HDPE (high density polyethylene);
- (c) "3" — V (vinyl);
- (d) "4" — LDPE (low density polyethylene);
- (e) "5" — PP (polypropylene);
- (f) "6" — PS (polystyrene);
- (g) "7" — OTHER.

**History of Section.**

P.L. 1990, ch. 270, § 1.

**Compiler's Notes.** As enacted by P.L. 1990, ch. 270, § 1, the word "midpoint" in the fourth sentence contained a misspelling.

**Delayed Effective Dates.** For the delayed effective date of this section see the note under this same heading following the chapter analysis.

**23-18.15-3. Regulations.** [Effective January 1, 1991.] — The director of the Rhode Island department of environmental management shall determine through rules and regulations which plastic bottles and rigid plastic containers may be exempt from the labeling requirements of § 23-18.15-2 including but not limited to the following:

- (1) readily identifiable plastic bottles and rigid plastic containers;
- (2) plastic bottles and rigid plastic containers for which there is no technological capacity for recycling, reclamation or reuse; and
- (3) plastic bottles and rigid plastic containers for which recycling, reclamation or reuse is not economically feasible.

**History of Section.**

P.L. 1990, ch. 270, § 1.

**Compiler's Notes.** As enacted by P.L. 1990, ch. 270, § 1, the first paragraph contained a reference to § 23-18.13-2. In order to reflect the redesignation of this chapter from Chapter 18.13 to Chapter 18.15 by the law revision officer of the joint committee on leg-

islative services, pursuant to § 43-2-2.1, the compiler substituted the present section references.

**Delayed Effective Dates.** For the delayed effective date of this section see the note under this same heading following the chapter analysis.

## CHAPTER 19

### SOLID WASTE MANAGEMENT CORPORATION

**SECTION.**

23-19-11.4. Initial resource recovery facilities.

**SECTION.**

23-19-28.1. Procedures to enforcement.

**23-19-11.4. Initial resource recovery facilities.** [Effective February 1, 1991.] — In view of the criticality of the solid waste disposal problem in the state, the procurement of the statutorily mandated Central Falls resource recovery facilities included in the initial resource recovery system shall not be subject to the provisions of chapter 2 of title 37.

**History of Section.**

P.L. 1990, ch. 461, § 13.

**Delayed Effective Dates.** Section 14 of

P.L. 1990, ch. 461 provides that the enactment of this section by that Act shall take effect February 1, 1991.

**23-19-28.1. Procedures to enforcement.** — (a) In any instance wherein there is a violation of its rules and regulations or any order of the corporation, the corporation shall have the power to order the violator to cease and desist, or to remedy such violations, and to impose administrative penalties. The corporation may impose administrative penalties only in accordance with the notice and hearing provisions of this chapter, and the corporation's enforcement plan, as may be amended from time to time, developed pursuant to the department of environmental management's regulations for reduction and recycling of commercial and non-municipal residential solid waste. Without being required to enter into any recognizance or to give surety for costs, the executive director may institute ad-



Eastern Region

Florida, Georgia, Louisiana, New Jersey  
North Carolina, Tennessee, Virginia

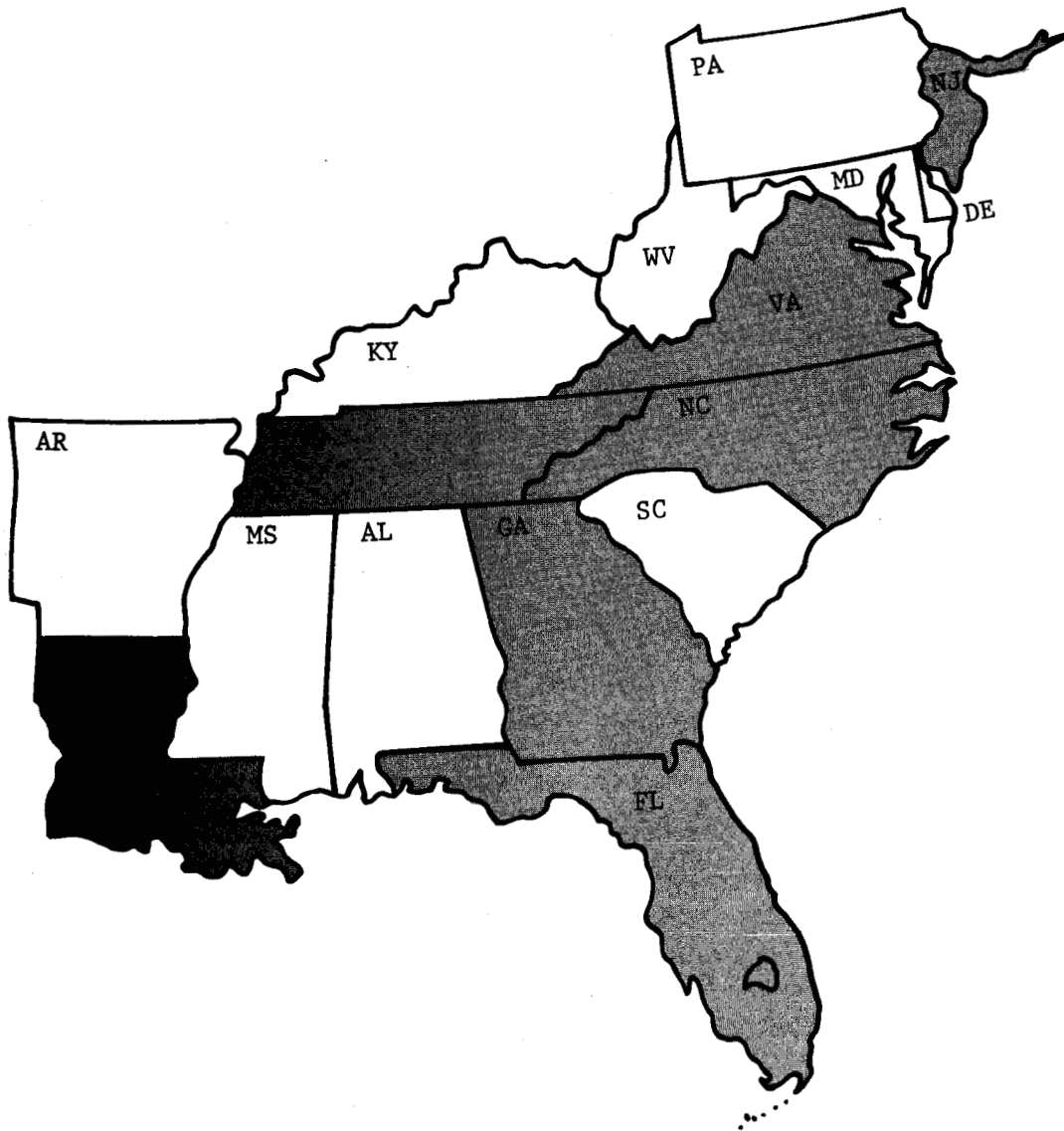

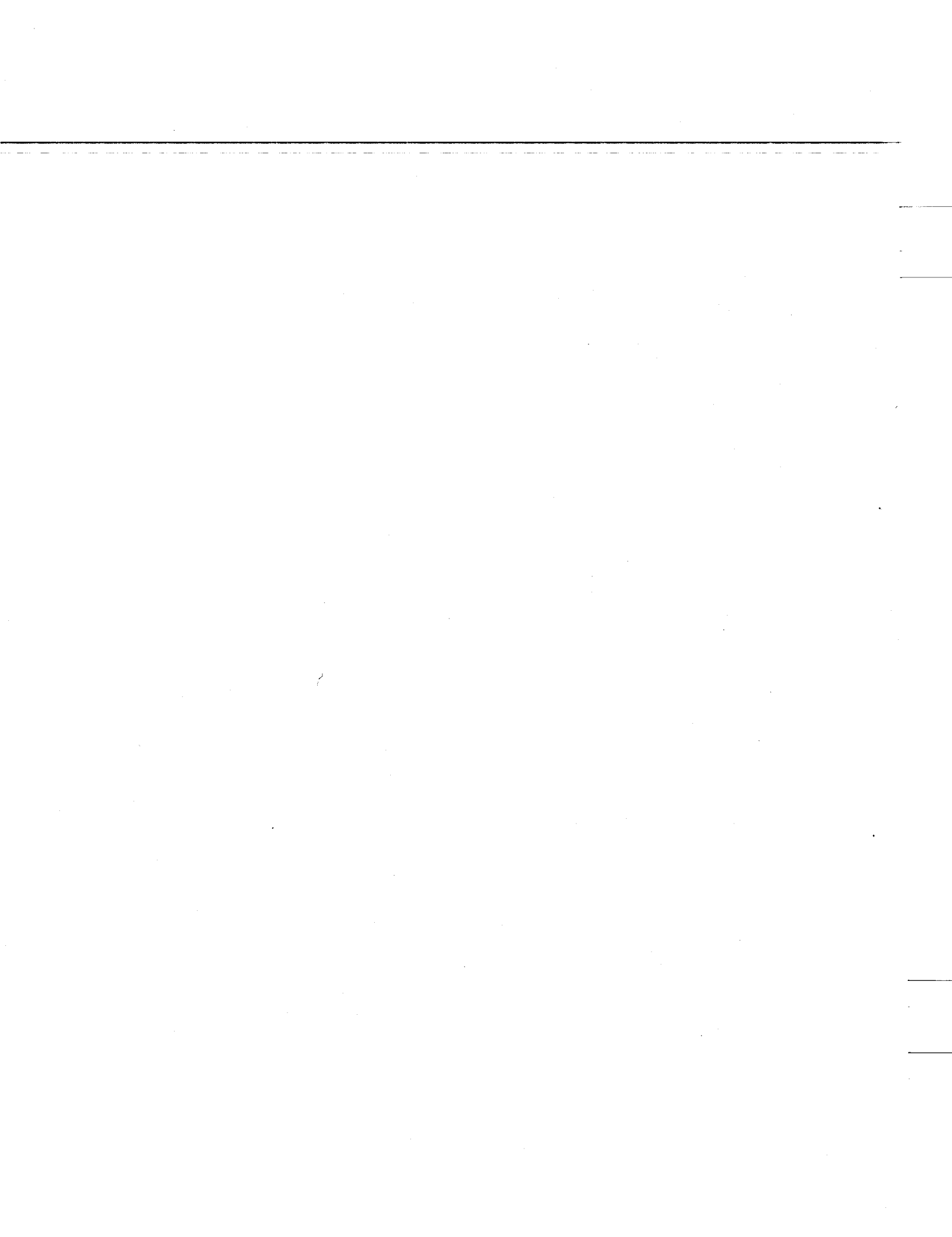

## FLORIDA

1. **Compliance Date:** July 1, 1990
2. **Scope:** Plastic container products (not limited to thermoplastics) for distribution, sale or exposure for sale in Florida:

<u>Type</u>	<u>Size</u>
<u>Nonsolid Food Liquid Containers</u> <u>Except Beverage Containers*/</u>	16 ounces or more †
<u>Rigid Plastic Containers</u>	8 ounces or more †

3. **Required Codes:**

<u>Resin Type</u>	<u>Code</u> <u>Number †</u>	<u>Code</u> <u>Letters</u>
Polyethylene Terephthalate	1	PET
High Density Polyethylene	2	HDPE
Vinyl	3	V
Low Density Polyethylene	4	LDPE
Polypropylene	5	PP
Polystyrene	6	PS
Other	7	OTHER

---

\*/ Subsection 9 of §403.708 appears to exclude beverage containers from the coding requirements. Authorities in Florida contend that this is not the intended meaning of the law. This issue may be clarified in the implementing regulations. For now, a conservative approach would be to code all beverage and non-solid food liquid containers to be distributed in Florida that are 16 ounces or larger. Companies that desire to take advantage of the apparent exclusion for beverage containers should be aware of the fact that there is no applicable definition of "beverage" in the statute. "Beverage" is defined elsewhere in Florida law as soda water, carbonated natural or mineral water, or other nonalcoholic carbonated drinks; soft drinks, whether or not carbonated; beer, ale, or other malt drink of whatever alcohol content; or a mixed wine drink or a mixed spirit drink." This definition is specifically applicable, however, only to container requirements other than resin coding (degradable ring carriers and detachable pull tabs).

† Denotes requirements that are consistent with the SPI Voluntary Code

- A. Base cups and labels: Not specified.
- B. Multilayer: Include as "7-OTHER."
- 4. **Required Symbol**: Numbers placed inside a triangle with letters below.
- 5. **Type and Location of Code**: Molded on the bottom of the bottle or container and shall be clearly visible; size not specified.
- 6. **Penalties**: Vague; none specified or \$10,000. The statute indicates that violations are punishable by civil penalty as provided in s. 403.141. That provision, however, appears to apply only to the types of violations (fairly serious in nature) defined in s. 403.161. Failure to code plastic containers is not among the list in s. 403.161, but Florida officials have advised that they consider s. 403.141 to have been implicitly amended when the coding requirement was enacted.

7. **Additional Information:**

Mr. Chris McGuire  
Department of Environmental Regulation  
Twin Towers Office Building  
2600 Blairstone Road  
Tallahassee, Florida 32399-2400  
(904) 488-9730  
Ms. Julie Gissendanner: (904) 488-0300

- 8. **Attachment**: FLA. STAT. ANN §403.708, October 1, 1989  
  
Letter from DER on use of chasing arrows  
memo from DER on general acceptability of  
SPI coding standards.

**§ 403.707****PUBLIC HEALTH**

after filing, to the water management district having jurisdiction where the area is to be located. The water management district shall prepare an advisory report as to the impact on water resources. This report shall contain the district's recommendations as to the disposition of the application and shall be submitted to the department no later than 30 days prior to the deadline for final agency action by the department.

(5) The department may not issue a construction permit pursuant to this part for a new solid waste landfill within 3,000 feet of Class I surface waters.

(6) The department may issue a construction permit pursuant to this part only to a solid waste management facility which provides the conditions necessary to control the safe movement of wastes or waste constituents into surface or ground waters or the atmosphere and which will be operated, maintained, and closed by qualified and properly trained personnel. Such facility shall, if necessary:

(a) Use natural or artificial barriers which are capable of controlling lateral or vertical movement of wastes or waste constituents into surface or ground waters.

(b) Have a foundation or base which is capable of providing support for structures and waste deposits and capable of preventing foundation or base failure due to settlement, compression, or uplift.

(c) Provide for the most economically feasible, cost-effective, and environmentally safe control of leachate, gas, stormwater, and disease vectors and prevent the endangerment of public health and the environment.

Open fires shall not be allowed to be used as a means of disposal at a solid waste landfill.

(7) Prior to application for a construction permit, an applicant shall designate to the department temporary backup disposal areas or processes for the resource recovery facility. Failure to designate temporary backup disposal areas or processes shall result in a denial of the construction permit.

(8) After July 1, 1990, any person who transports biohazardous waste within the state must register with the department prior to engaging in the transport of biohazardous waste.

(9) The department may refuse to issue a permit to an applicant who by past conduct in this state has repeatedly violated pertinent statutes, rules, or orders or permit terms or conditions relating to any solid waste management facility and who is deemed to be responsible as defined by department rule. For the purposes of this subsection, an applicant includes the owner or operator of the facility, or if the owner or operator is a business entity, a parent of a subsidiary corporation, a partner, a corporate officer or director, or a stockholder holding more than 50 percent of the stock of the corporation.

Amended by Laws 1988, c. 88-130, § 13, eff. Oct. 1, 1988.

<sup>1</sup> As enacted, the term "this act" refers to Laws 1988, c. 88-130.

**403.7075. Submission of plans for certain solid waste management facilities; conditions**

All plans and applications for a permit to construct and operate a solid waste management facility as provided in s. 403.707 may be prepared and submitted by any person acting as a public officer employed by a county or a municipality when said public officer states therein that the construction of the solid waste management facility is estimated to cost less than \$10,000. Any law to the contrary notwithstanding, the construction cost of a solid waste management facility, for the purposes of this section, shall not include land acquisition cost or the cost of equipment used to construct and maintain same.

Amended by Laws 1988, c. 88-130, § 14, eff. Oct. 1, 1988.

**403.708. Prohibition; penalty**

(1) No person shall:

(a) Place or deposit any solid waste in or on the land or waters located within the state except in a manner approved by the department and consistent with applicable approved

programs of counties or municipalities. However, nothing in this act shall be construed to prohibit the disposal of solid waste without a permit as provided in s. 403.707(2).

(b) Burn solid waste except in a manner prescribed by the department and consistent with applicable approved programs of counties or municipalities.

(c) Construct, alter, modify, or operate a solid waste management facility or site without first having obtained from the department any permit required by s. 403.707.

(d) Transport biohazardous waste within the state without first having registered with the department as provided in s. 403.707.

(2) After January 1, 1989, no beverage shall be sold or offered for sale within the state in a beverage container designed and constructed so that the container is opened by detaching a metal ring or tab.

(3) After July 1, 1989, no container shall be sold or offered for sale within the state that is connected to other containers by a separate holding device constructed of plastic rings unless such rings are composed of material which is degradable within 120 days, or by any other device unless such device is composed of material which is degradable within 120 days. Notice of degradability shall be embossed or otherwise indicated on the holding device for ease of inspection.

(4) For purposes of subsections (2), (3), (10), and (11):

(a) "Degradable," with respect to any material, means that such material, after being discarded, is capable of decomposing to components other than heavy metals or other toxic substances, after exposure to bacteria, light, or outdoor elements.

(b) "Beverage" means soda water, carbonated natural or mineral water, or other nonalcoholic carbonated drinks; soft drinks, whether or not carbonated; beer, ale, or other malt drink of whatever alcoholic content; or a mixed wine drink or a mixed spirit drink.

(c) "Beverage container" means an airtight container which at the time of sale contains 1 gallon or less of a beverage, or the metric equivalent of 1 gallon or less, and which is composed of metal, plastic, or glass or a combination thereof.

(5) The Division of Alcoholic Beverages and Tobacco of the Department of Business Regulation may impose a fine of not more than \$100 on any person currently licensed pursuant to s. 561.14 for each violation of the provisions of subsection (2) or subsection (3). If the violation is of a continuing nature, each day during which such violation occurs shall constitute a separate and distinct offense and shall be subject to a separate fine.

(6) The Department of Agriculture and Consumer Services may impose a fine of not more than \$100 on any person not currently licensed pursuant to s. 561.14 for each violation of the provisions of subsection (2) or subsection (3). If the violation is of a continuing nature, each day during which such violation occurs shall constitute a separate and distinct offense and shall be subject to a separate fine.

(7) Fifty percent of each fine collected pursuant to subsections (5) and (6) shall be deposited into the Solid Waste Management Trust Fund. The balance of fines collected pursuant to subsection (5) shall be deposited into the Alcoholic Beverage and Tobacco Trust Fund for the use of the division for inspection and enforcement of the provisions of this section. The balance of fines collected pursuant to subsection (6) shall be deposited into the General Inspection Trust Fund for the use of the Department of Agriculture and Consumer Services for inspection and enforcement of the provisions of this section.

(8) The Division of Alcoholic Beverages and Tobacco and the Department of Agriculture and Consumer Services shall coordinate their responsibilities under the provisions of this section to ensure that inspections and enforcement are accomplished in an efficient, cost-effective manner.

(9) On or after July 1, 1990, no person shall distribute, sell, or expose for sale in this state any plastic container product unless the product has a molded label indicating the plastic resin used to produce the plastic container product. The label must appear on the bottom of the plastic container product and be clearly visible. This label must consist of a number placed inside a triangle and letters placed below the triangle. All plastic beverage containers and all nonsolid food liquid containers of less than 16 ounces and all

rigid plastic containers of less than 8 ounces shall not be required to be labeled under this section. The numbers and letters shall be as follows:

- (a) For polyethylene terephthalate, the letters "PET" and the number 1.
- (b) For high density polyethylene, the letters "HDPE" and the number 2.
- (c) For vinyl, the letter "V" and the number 3.
- (d) For low density polyethylene, the letters "LDPE" and the number 4.
- (e) For polypropylene, the letters "PP" and the number 5.
- (f) For polystyrene, the letters "PS" and the number 6.
- (g) For any other, including multilayer, the letters "OTHER" and the number 7.

(10)(a) After January 1, 1990, no plastic bag shall be provided at any retail outlet to any retail customer to use for the purpose of carrying items purchased by that customer unless the bag is composed of material which is degradable within 120 days. Notice of degradability shall be printed on each bag.

(b) For purposes of this subsection, "retail outlet" means any establishment 80 percent or more of the income of which is from retail sales. This term does not mean any establishment whose primary purpose is to sell food prepared at such establishment for immediate consumption.

(c) The owner of a retail outlet violating this subsection shall be subject to a fine of \$100 per location. Each day of a continuing violation shall be considered as a separate violation.

(d) One half of the fines collected pursuant to this subsection shall be deposited in the Solid Waste Management Trust Fund. The balance of such fines shall be deposited into the operating account of the enforcing agency.

(11) No person shall:

(a) On or after October 1, 1990, distribute, sell, or expose for sale in this state any product packaged in a container or packing material manufactured with fully halogenated chlorofluorocarbons (CFC). Producers of containers or packing material manufactured with chlorofluorocarbons (CFC) are urged to introduce alternative packaging materials which are environmentally compatible.

(b) Distribute, sell, or offer for sale in this state any polystyrene foam or plastic-coated paper product which is to be used in conjunction with food for human consumption unless such product is composed of material which is degradable within 12 months or less. This requirement shall be effective 1 year after such products have been certified as safe by the United States Food and Drug Administration and are made available in commercial quantities. Determination of the degradability of these products shall be made by the Secretary of Environmental Regulation based on a preponderance of evidence available from reputable private and government research agencies. Businesses and industries that use polystyrene foam and plastic-coated paper products that are not degradable as required by this paragraph are encouraged to formulate a 3-year plan to research, test, and implement production technologies that will allow the product to meet the degradability requirements by January 1, 1992.

(12) The packaging of products manufactured or sold in the state may not be controlled by governmental rule, regulation, or ordinance adopted after March 1, 1974, other than as expressly provided in this act.<sup>1</sup>

(13) Violations of this part or rules, regulations, permits, or orders issued thereunder by the department and violations of approved local programs of counties or municipalities or rules, regulations, or orders issued thereunder shall be punishable by a civil penalty as provided in s. 403.141.

(14) The department or any county or municipality may also seek to enjoin the violation of, or enforce compliance with, this part or any program adopted hereunder as provided in s. 403.131.

(15) In accordance with the following schedule, no person who knows or who should know of the nature of such solid waste shall dispose of such solid waste in landfills:

(a) Lead-acid batteries, after January 1, 1989. Lead-acid batteries also shall not be disposed of in any waste-to-energy facility after January 1, 1989. To encourage proper collection and recycling, all persons who sell lead-acid batteries at retail shall accept used lead-acid batteries as trade-ins for new lead-acid batteries.

(b) Used oil, after October 1, 1988.

(c) Yard trash, after January 1, 1992, except in unlined landfills classified by department rule. Yard trash that is source separated from solid waste may be accepted at a solid waste disposal area where the area provides and maintains separate yard trash composting facilities.

(d) White goods, after January 1, 1990.

Prior to the effective dates specified in paragraphs (a)-(d), the department shall identify and assist in developing alternative disposal, processing, or recycling options for the solid wastes identified in paragraphs (a)-(d).

Amended by Laws 1988, c. 88-130, § 15, eff. Oct. 1, 1988.

<sup>1</sup> As enacted, the term "this act" refers to Laws 1988, c. 88-130.

#### 403.7085. Animal parts, fats, byproducts, waste products, vegetable oils disposal

A commercial establishment, excluding an establishment licensed pursuant to chapter 509, that processes food products for human consumption may not dispose of any animal parts, fats, byproducts, waste products, or vegetable oils, liquid or solid, in a landfill unless approved by the department. The department may establish by rule appropriate thresholds or amounts for these materials, as well as additional subcategories of these materials, that are exempt from this requirement. In making a determination for exemption the department shall find that such an exemption is not likely to be harmful to the public health, safety, or welfare.

Added by Laws 1988, c. 88-130, § 16, eff. Oct. 1, 1988.

#### 403.709. Solid Waste Management Trust Fund

(1) There is created the Solid Waste Management Trust Fund, to be administered by the Department of Environmental Regulation for the purposes of:

(a) Funding solid waste activities of the department, such as providing technical assistance to local governments, performing solid waste regulatory and enforcement functions, preparing solid waste documents, and implementing solid waste education programs;

(b) Making grants and awards to local governments as provided in this act;<sup>1</sup>

(c) Providing funding for demonstration projects as provided by this act<sup>1</sup>; and

(d) Providing funding for research by state universities and independent nonprofit colleges and universities within the state which are accredited by the Southern Association of Colleges and Schools as provided by this act.<sup>1</sup>

(2) Moneys allocated to the fund from waste tire fees shall be accounted for separately within the fund and shall be used in the following manner, in order of priority:

(a) To pay department administration costs for administering these funds and programs.

(b) To provide funding for research and demonstration projects relating to solving solid waste problems resulting from waste tires.

(c) To provide funds for removal of tires from an illegal waste tire site when the site owner is financially incapable of complying with the law.

(d) To provide grants to local governments as provided in this act.<sup>1</sup>

Amended by Laws 1986, c. 88-130, § 17, eff. Oct. 1, 1988.

<sup>1</sup> As enacted, the term "this act" refers to Laws 1988, c. 88-130.





# Florida Department of Environmental Regulation

Twin Tower Office Bldg. • 2600 Blair Stone Road • Tallahassee, Florida 32399-2400

Rob Martinez, Governor

Dale Twachtmann, Secretary

John Cheasee, Assistant Secretary

April 03, 1990

Senator George Kirkpatrick  
240 Senate Office Building  
Tallahassee, Florida 32301

Dear Senator Kirkpatrick:

This is in response to your inquiry regarding the Department's interpretation of Section 403.708(9), Florida Statutes, prohibiting the distribution or sale of plastic container products without a molded label indicating the plastic resin used to produce the container.

The code described in the Florida law differs from the Society of the Plastics Industry (SPI) Voluntary Container Coding System in several ways. The most significant of these is that our law requires a number placed inside a triangle while SPI's code specifies a number placed within three triangulated arrows.

We have met with Mr. Stephen Alexander, Government Affairs Manager for the Council for Solid Waste Solutions for SPI and assured him that the SPI code meets the requirements of our law. Further, we will be working with SPI on interpretation of other aspects of Florida's coding law to be sure that it is understood that we wish to assist in the establishment of a uniform national code.

We hope this information addresses your concerns. If you or your staff need more information, please give me a call.

Sincerely,

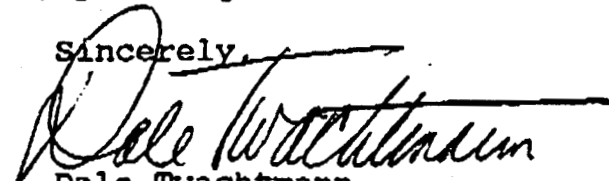

Dale Twachtmann  
Secretary

DT/jgw/pg

Enclosure

cc: Rick Wilkins, Director  
Division of Waste Management, DER



Location	_____
Location	_____
Date	_____

# Interoffice Memorandum

TO: Rick Wilkins, Director  
Division of Waste Management

Deputy Assistant Secretaries

FROM: Dale Twachtmann, Secretary

SUBJECT: Policy Memorandum for the Interpretation of  
Section 403.708(9), F.S. - Coding of Plastic Container  
Products

DATE: June 18, 1990

Section 403.708(9), F.S., sets forth requirements for the coding of plastic container products. The Society for the Plastics Industry (SPI) has created voluntary standards for the coding of plastic products, which are in use nationwide. We support SPI's efforts, and believe that the voluntary standards meet the intent of the Florida law. To the extent possible, therefore, Florida law should be read to conform to SPI's standards in order to promote consistency in packaging requirements nationwide.

Four differences between Florida law and the SPI standards have been identified. The following addresses our policy interpretation regarding these apparent differences.

1. Florida law requires the use of the letters "PET" on containers of polyethylene terephthalate. SPI's standards require the letters "PETE." Since PETE and PET are both common acronyms for polyethylene terephthalate, the Department considers them synonymous, and either acronym is acceptable in Florida.
2. Florida law requires that numbers be placed inside of a triangle. SPI's standards require that numbers be placed inside a "chasing arrows" symbol in a triangular form. Because the chasing arrows are in a triangular shape, the Department considers this symbol to comply with Florida law.

3. Florida law requires that the label appear on the bottom of the container. SPI's standards require that the label appear on or near the bottom of the container. Florida law should not be read to require the label on the bottom side of the container, but only to require the label on the bottom portion of the container, which may include the sides near the bottom of the container.

4. Florida law exempts from the labelling requirement "plastic beverage containers and all nonsolid food liquid containers of less than 16 ounces and all rigid plastic containers of less than 8 ounces." SPI's standards exempt all bottles of less than 16 ounces and all rigid plastic containers of less than 8 ounces. The phrase "nonsolid food liquid containers" has no special meaning in law or use, and seems to be both internally inconsistent and in conflict with SPI's standards. The Department believes that the only reasonable interpretation of this phrase is that "nonsolid food" and "liquid" are separate modifiers of the word container. Therefore, this phrase should be read to apply to nonsolid food containers or liquid containers.

SPI's standards include definitions of some terms found in Florida law. It is the Department's intent to define terms as consistently as possible with SPI's definitions.

A "plastic container product" means a plastic bottle or a rigid plastic container. It does not include any container which is designed solely to hold biohazardous waste or other medical waste.

A "plastic beverage container," a "nonsolid food container," and a "liquid container" are all interpreted to include only bottles which hold the referenced contents.

A "plastic bottle" means a plastic container intended for single use that has a neck that is smaller than the body of the container, accepts a screw-type, snap cap or other closure.

A "rigid plastic container" means any formed or molded container, other than a bottle, intended for single use, composed predominantly of plastic resin, and having a relatively inflexible finite shape or form.

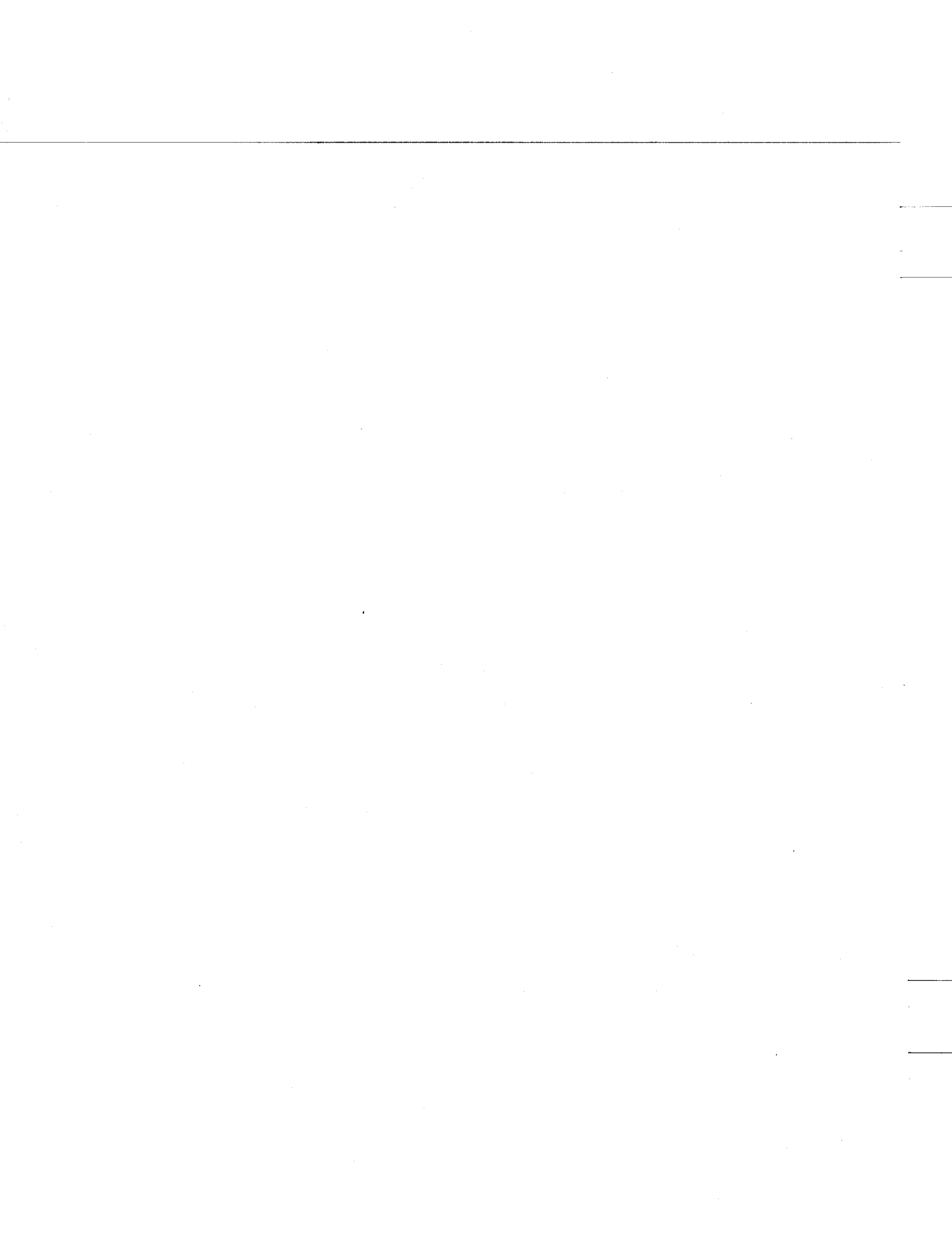

## GEORGIA

1. **Compliance Date:** January 1, 1991
2. **Scope:** Plastic containers manufactured for use in Georgia or offered for sale in Georgia:

<u>Type</u>	<u>Size</u>
<u>Rigid Plastic Containers</u> -- Not defined.	Not specified.
<u>Plastic Bottles</u> -- Not defined.	Not specified.

3. **Required Codes:**

<u>Resin Type</u>	<u>Code Number †</u>	<u>Code Letters †</u>
Polyethylene Terephthalate	1	PETE
High Density Polyethylene	2	HDPE
Vinyl	3	V
Low Density Polyethylene	4	LDPE
Polypropylene	5	PP
Polystyrene	6	PS
Other	7	OTHER

A. Base cups and labels: If the secondary material is compatible with the basic material in recycling systems, the container should bear the code of the basic material (even when the code is applied to the basecup); otherwise, "7-OTHER" is appropriate.

B. Multilayer: Include as "7-OTHER."

4. **Required Symbol:** RIS; size not specified.
5. **Type and Location of Symbol:** Molded into the plastic product; location not specified.

† Denotes requirements that are consistent with the SPI Voluntary Code

6. **Penalties:** None specified.

7. **Additional Information:**

Mr. John Taylor  
Chief, Land Protection Branch  
Division of Environmental Protection  
Department of Natural Resources  
205 Butler Street, Suite 1152  
Atlanta, Georgia 30334  
(404) 656-2833

8. **Attachments:** Senate Bill 533, as passed

† Denotes requirements that are consistent with the SPI Voluntary Code

## SENATE BILL 533

By: Senators McKenzie of the 14th, Baldwin of the 29th,  
Johnson of the 47th and others

**AS PASSED!**

## AN ACT

To amend Chapter 8 of Title 12 of the Official Code of Georgia Annotated, relating to waste management, so as to provide for the comprehensive revision of provisions relating to solid waste management; to provide for a short title; to provide for legislative intent; to provide for definitions; to provide for powers and duties of the Board of Natural Resources and the director of the Environmental Protection Division of the Department of Natural Resources; to provide for permits; to provide for procedures and requirements with respect to permits; to provide for examination and certification of certain operators; to provide for procedures and limitations with respect to siting near certain county boundaries, certain National Historic Sites, or certain significant ground-water recharge areas; to provide for restrictions regarding the permitting of certain landfills; to provide for public meetings with respect to site selection; to provide for notice; to provide for standards for certain facilities receiving special solid waste; to provide for transportation, fees, inspection, and prohibitions with respect to special solid waste; to provide for a solid waste trust fund; to require adequate financial responsibility with respect to certain facilities; to prohibit certain acts with respect to solid waste handling; to regulate the disposal of certain lead acid vehicle batteries; to provide for investigation and enforcement authority of the director; to provide for certain confidentiality; to provide for certain orders; to provide for administrative hearings and procedures; to provide for

Department of Community Affairs; and the Department of Natural Resources.

(b) The council shall meet as necessary and shall determine what actions, if any, are needed to facilitate the development and expansion of markets for recovered materials in Georgia and shall prepare an annual report with recommendations to the Governor and General Assembly.

(c) The council shall function for a period of five years from its establishment, at which time it shall either be reauthorized or shall stand abolished.

12-8-34. (a) On and after January 1, 1991, it shall be unlawful to manufacture for use in Georgia or offer for sale in Georgia any rigid plastic container or rigid plastic bottle which is not labeled in accordance with subsection (b) of this Code section.

(b) On and after January 1, 1991, any rigid plastic container or rigid plastic bottle manufactured for use in Georgia or offered for sale in Georgia shall be labeled with a code molded into the plastic product which indicates the resin used to produce the bottle or container. Such coding shall conform with the following:

(1) Rigid plastic containers or rigid plastic bottles with basecaps or other components of the secondary material may, if the materials are compatible in recycling systems, carry the code of the basic material (even when the basic code is applied to the basecap of the secondary material); otherwise '7-other' is appropriate.

(2) The label code shall consist of a number placed inside a triangle and letters placed below



the triangle as required by paragraph (3) of this subsection. The triangle shall be equilateral, formed by three arrows with the apex of each point of the triangle at the midpoint of each arrow, rounded with a short radius. The pointer (arrowhead) of each arrow shall be at the midpoint of each side of the triangle with a short gap separating the pointer from the base of the adjacent arrow. The triangle, formed by the three arrows curved at their midpoints shall depict a clockwise path around the code number;

(3) The numbers and letters used on labels described in subsections (a) and (b) of this Code section and their interpretations shall be as follows:

'1-PETE' (polyethylene terephthalate)

'2-HDPE' (high-density polyethylene)

'3-V' (vinyl)

'4-LDPE' (low-density polyethylene)

'5-PP' (polypropylene)

'6-PS' (polystyrene)

'7-OTHER' All other resins and layered multimaterial.

12-8-35. (a) The commissioner of administrative services shall:

(1) By July 1, 1990, commence a review of all goods and products purchased to determine what percentage of state purchases contain recycled materials, which review shall be completed by December 31, 1991, and, upon completion of his review, file a report of his findings with the General Assembly and the Governor; and

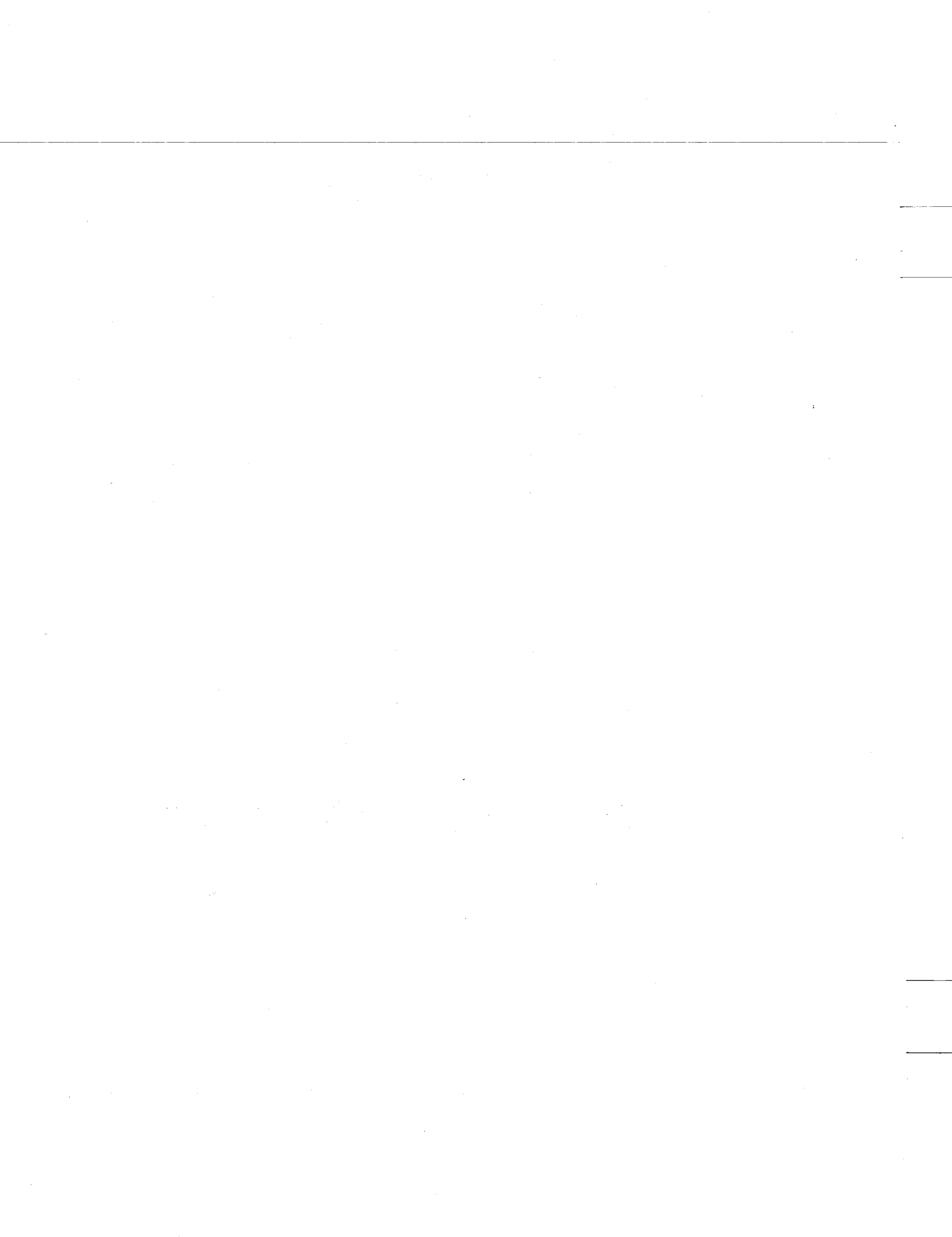

## LOUISIANA

1. **Compliance Date:** January 1, 1991
2. **Scope:** All plastic bottles and plastic containers (not limited to thermoplastics) knowingly and intentionally distributed, sold, or offered for sale in Louisiana:

<u>Type</u>	<u>Size</u>
<u>Plastic Bottles</u> -- Container with neck smaller than its body and accepts a closure.	16 ounces to 5 gallons †
<u>Rigid Plastic Containers</u> -- Other than bottle; intended for single use; relatively inflexible finite shape.	8 ounces to 5 gallons †

3. **Required Codes:**

<u>Resin Type</u>	<u>Code Number</u>	<u>Code Letters</u>
Polyethylene Terephthalate High Density Polyethylene Vinyl Low Density Polyethylene Polypropylene Polystyrene Other	"Conform to voluntary Code developed by SPI" †	

- A. Base cups and labels: Rigid plastic bottles or rigid plastic containers with labels and base cups of a different material shall be coded by their basic material. †
- B. Multilayer: Conform to voluntary guidelines. †
4. **Required Symbol:** RIS; Size shall conform to SPI guidelines. †
5. **Type and Location of Code:** Molded imprint or raised symbol on or near the bottom of the bottle or container. †
6. **Penalties:** None Specified.

† Denotes requirements that are consistent with the SPI Voluntary Code

**7. Additional Information:**

Butch Stegall  
Louisiana Department of Environmental Quality  
Office of Solid Waste Management  
P.O. Box 44307  
Baton Rouge, Louisiana 70804-4274  
(504) 342-9013

**8. Attachment:** Louisiana R.S. 30:2412, 2422 (H. B. No. 1199 attached)

H.B. NO. 1199

(15) "Waste tire processing facility" means a site where equipment is used to cut, burn, or otherwise alter whole waste tires so that they are no longer whole.

(16) "White goods" means inoperative and discarded refrigerators, ranges, water heaters, freezers, and other similar domestic and commercial large appliances.

(17) "Solid waste" means any garbage, refuse, sludge, and other discarded material, including those in a solid, liquid or semisolid state resulting from residential, community, or commercial activities. As used in this Chapter the term "solid waste" shall not include mining, agricultural, special and industrial wastes, or hazardous and infectious wastes. It also does not include or mean solid or dissolved material in domestic sewage or solid or dissolved materials in irrigation return flows or industrial discharges which are point sources subject to permits under R.S. 30:2074, or source, special nuclear, or byproduct material as defined by the Atomic Energy Act of 1954 (42 U.S.C. 2011 et seq.), as amended, or hazardous waste subject to permits under R.S. 30:2171 et seq. The definition of solid waste shall not include recovered materials.

(18) "Label" means a molded imprint or raised symbol on or near the bottom of a plastic product.

(19) "Plastic bottle" means a plastic container that has a neck that is smaller than the body of the container, accepts a screw-type, snap cap, or other closure and has a capacity of sixteen fluid ounces or more, but less than five gallons.

(20) "Rigid plastic container" means any formed or molded container, other than a bottle, intended for single use, composed predominantly of plastic resin, and having a relatively inflexible finite shape or form with a capacity of eight ounces or more but less than five gallons.

§2413. Powers and duties of the secretary; fees; local government

A. The secretary shall have the following powers and duties:

rules shall include the provisions for establishment of a list of recyclable materials. No rules and regulations adopted by the secretary shall apply to any materials prior to their entering into the solid waste stream.

B. The department shall, at least annually, review the list of recyclable items. This review shall consider the available recycling technologies, markets, cost, and any other factors as deemed to be appropriate when compiling and reviewing the list of recyclable items.

C. The secretary may require each solid waste management facility to provide for a drop-off location for source separated recyclable materials if deemed necessary to meet the purposes and goals of this Chapter.

D. On or after January 1, 1991, no person shall knowingly and intentionally distribute, sell, or offer for sale in this state any plastic bottle sixteen ounces or larger, or rigid plastic containers eight ounces or larger unless the product is labeled with a code indicating the plastic resin used to produce the bottle or container. Rigid plastic bottles or rigid plastic containers with labels and basecaps of a different material shall be coded by their basic material. The code shall conform to the code developed by the Society of the Plastics Industry.

E. On or after January 1, 1991, no container shall knowingly and intentionally be sold or offered for sale in this state that is connected to other containers by a separate holding device constructed of plastic rings unless such rings are composed of such material which is capable of being recycled or degraded in one hundred twenty days or less.

Section 2. The Department of Natural Resources is hereby directed to evaluate the use of two million five hundred thousand dollars of the oil overcharge settlement funds by the Department of Environmental Quality to provide for the initial funding for programs and activities authorized by this Act. The department shall coordinate with the Department of Natural Resources to insure that the use of the funds is in accord with all applicable rules and

## NEW JERSEY

1. **Compliance Date:** January 1, 1991
2. **Scope:** Plastic Containers and Plastic Bottles, sold or distributed in New Jersey.

<u>Type</u>	<u>Size</u>
<p><u>Plastic Containers</u> --                      Formed or molded rigid container hermetically sealed or made airtight with cap; intended for single use; wall thickness not less than 0.010 inches; does not include bottles.</p>	8 ounces to 5 gallons †
<p><u>Plastic Bottles</u> -- Plastic beverage container composed of thermoplastic synthetic polymeric material.</p>	16 ounces to 5 gallons †

### 3. Required Codes:

<u>Resin Type</u>	<u>Code Number</u> †	<u>Code Letters</u> †
Polyethylene Terephthalate	1	PETE
High Density Polyethylene	2	HDPE
Vinyl	3	V
Low Density Polyethylene	4	LDPE
Polypropylene	5	PP
Polystyrene	6	PS
Multilayer	7	OTHER

- A. Base cups and labels: Any plastic bottle or plastic container with a label or base cup affixed thereto, the composition of which consists of a different material than the bottle or container itself, shall be coded by its basic material.
- B. Multilayer: Include as "7-OTHER."

† Denotes requirements that are consistent with the SPI Voluntary Code

4. **Required Symbol:** RIS; Size not specified.†
5. **Type and Location of Code:** Not specified.
6. **Penalties:** Any person convicted of a violation shall be subject to a penalty of between \$500 and \$1,000 for each offense. For continuing violations, each day may constitute a separate offense. Violations may also be enjoined.
7. **Additional Information:**

State of New Jersey  
Department of Environmental Protection  
Recycling Program  
401 East State St.  
Trenton, New Jersey 08625  
(609) 292-0331

8. **Attachments:** 1989 N.J. Laws 4303

† Denotes requirements that are consistent with the SPI Voluntary Code



P.L.1989, CHAPTER 268, approved January 4, 1990  
1989 Assembly No. 4303

3/90 Revision

1 AN ACT establishing a uniform coding system for plastic bottles  
2 and containers, and supplementing P.L.1987, c.102  
3 (C.13:1E-99.11 et al.).  
4

5 BE IT ENACTED by the Senate and General Assembly of the  
6 State of New Jersey:

7 1. As used in this act:

8 "Beverage" means milk, alcoholic beverages, including beer or  
9 other malt beverages, liquor, wine, vermouth and sparkling wine,  
10 and nonalcoholic beverages, including fruit juice, mineral water  
11 and soda water and similar nonalcoholic carbonated and  
12 noncarbonated drinks intended for human consumption;

13 "Beverage container" means an individual, separate,  
14 hermetically sealed, or made airtight with a metal or plastic cap,  
15 bottle or can composed of glass, metal, plastic or any  
16 combination thereof, containing a beverage;

17 "Commissioner" means the Commissioner of Environmental  
18 Protection;

19 "Department" means the Department of Environmental  
20 Protection;

21 "Plastic bottle" means any plastic beverage container having a  
22 capacity of at least 16 fluid ounces but less than 5 United States  
23 gallons, and composed of thermoplastic synthetic polymeric  
24 material;

25 "Plastic container" means any formed or molded and  
26 hermetically sealed, or made airtight with a metal or plastic cap,  
27 rigid container, other than a plastic bottle, intended for  
28 single-use and having a capacity of at least 8 ounces but less than  
29 5 United States gallons with a minimum wall thickness of not less  
30 than 0.010 inches, and composed primarily of thermoplastic  
31 synthetic polymeric material.

32 2. a. On or after January 1, 1991, no person shall sell, offer  
33 for sale, or distribute any plastic bottle or plastic container in

1 this State unless the bottle or container is labeled with a material  
2 code indicating the plastic resin used to produce the bottle or  
3 container. Any plastic bottle or plastic container with a label or  
4 basecup affixed thereto, the composition of which consists of a  
5 different material than the bottle or container itself, shall be  
6 coded by its basic material.

7 b. The material code shall consist of a uniform symbol and  
8 identification number, and an acronym comprising no more than  
9 five letters. The symbol shall consist of a triangular-shaped  
10 configuration of three arrows with a specific number placed  
11 within the center of the symbol to indicate the composition of  
12 the material used to produce the bottle or container. The  
13 acronym shall be placed below the triangle of arrows. The  
14 triangle shall be equilateral, formed by three arrows with the  
15 apex of each point of the triangle at the midpoint of each arrow,  
16 rounded with a short radius. The pointer (arrowhead) of each  
17 arrow shall be at the midpoint of each side of the triangle with a  
18 short gap separating the pointer from the base of the adjacent  
19 arrow. The triangle, formed by the three arrows curved at their  
20 midpoints shall depict a clockwise path around the code number.

21 c. The material code shall consist of an identification number  
22 and acronym as follows:

- 23 (1) Polyethylene terephthalate: "1" and "PETE";
- 24 (2) High density polyethylene: "2" and "HDPE";
- 25 (3) Vinyl: "3" and "V";
- 26 (4) Low density polyethylene: "4" and "LDPE";
- 27 (5) Polypropylene: "5" and "PP";
- 28 (6) Polystyrene: "6" and "PS"; and
- 29 (7) All other plastic resins and laminates: "7" and  
30 "OTHER".

31 d. The commissioner shall maintain on file in the department  
32 for public inspection copies of the material code provided in  
33 subsection c. of this section. The department shall provide a  
34 copy to any person upon request.

35 3. a. Any person convicted of a violation of this act shall be  
36 subject to a penalty of not less than \$500.00 nor more than  
37 \$1,000.00 for each offense, to be collected in a civil action by a  
38 summary proceeding under "the penalty enforcement law,  
39 (N.J.S.2A:58-1 et seq.), or in any case before a court of

1 competent jurisdiction wherein injunctive relief has been  
2 requested. The Superior Court and the municipal court shall have  
3 jurisdiction to enforce the provisions of "the penalty enforcement  
4 law" in connection with this act. If the violation is of a  
5 continuing nature, each day during which it continues constitutes  
6 an additional, separate, and distinct offense.

7 b. The department may institute a civil action for injunctive  
8 relief of enforce this act and to prohibit and prevent a violation  
9 of this act, and the court may proceed in the action in a summary  
10 manner.

11 4. The commissioner shall adopt, within one year of the  
12 effective date of this act and pursuant to the "Administrative  
13 Procedure Act," P.L.1968, c.410 (C.52:14B-1 et seq.), rules and  
14 regulations necessary to implement this act.

15 5. This act shall take effect immediately.

#### 18 STATEMENT

19  
20 This bill would establish a uniform coding system to identify  
21 plastic bottles and containers by the basic plastic resin used in  
22 their manufacture. The coding system has been developed by the  
23 Society of the Plastics Industry (SPI) for adoption by the states in  
24 order to facilitate the recycling of these items.

25 Specifically, the bill provides that after January 1, 1991, no  
26 plastic bottle or plastic container may be sold or distributed in  
27 this State unless the bottle or container is labeled with a material  
28 code indicating the plastic resin used to produce the bottle or  
29 container. A "plastic bottle" is defined as any plastic beverage  
30 container having a capacity of at least 16 fluid ounces but less  
31 than 5 United States gallons. A "plastic container" refers to any  
32 formed or molded and hermetically sealed rigid container, other  
33 than a plastic bottle, intended for single-use and having a  
34 capacity of at least 8 ounces but less than 5 United States gallons.

35 In the case of a plastic bottle or container with a label or  
36 basecup affixed thereto, the composition of which consists of a  
37 different material than the bottle or container itself, the bottle  
38 or container would be coded by its basic material.

39 The material code consists of a uniform symbol and

1 identification number, and an acronym comprising no more than  
2 five letters. The symbol consists of a triangular-shaped  
3 configuration of three arrows with a specific number placed  
4 within the center of the symbol to indicate the composition of  
5 the material used to produce the bottle or container. The  
6 acronym is placed below the triangle of arrows.

7 The bill provides that the Commissioner of the Department of  
8 Environmental Protection must maintain on file in the  
9 department for public inspection copies of the material code  
10 established under this act, and the department must provide a  
11 copy to any person upon request.

12 The bill provides further that any person convicted of a  
13 violation of this act would be subject to a civil penalty of not less  
14 than \$500.00 nor more than \$1,000.00 for each offense.

15 Six states - California, Connecticut, Florida, Illinois,  
16 Minnesota and Wisconsin - have enacted legislation to adopt the  
17 SPI uniform plastic coding system to date.

18  
19

## 20 ENVIRONMENT

### 21 Solid Waste

22

23 Establishes a uniform coding system for plastic bottles and  
24 containers.

## NORTH CAROLINA

1. **Compliance Date:** July 1, 1991
2. **Scope:** Plastic container products (not limited to thermo-plastics) for distribution, sale or exposure for sale in the state:

<u>Type</u>	<u>Size</u>
<u>Nonsolid Food Liquid</u> <u>Except Beverage Containers*/</u>	16 ounces or more †
<u>Rigid Plastic Containers</u>	8 ounces or more †

3. **Required Codes:**

<u>Resin Type</u>	<u>Code</u> <u>Number</u> †	<u>Code</u> <u>Letters</u> †
Polyethylene Terephthalate	1	PETE
High Density Polyethylene	2	HDPE
Vinyl	3	V
Low Density Polyethylene	4	LDPE
Polypropylene	5	PP
Polystyrene	6	PS
Other	7	OTHER

A. Base cups and labels: Not specified. †

B. Multilayer: Include as "7-OTHER."

4. **Required Symbol:** RIS; size not specified. †
5. **Type and Location of Code:** Molded on the bottom of the bottle or container and shall be clearly visible; size not specified.
6. **Penalties:** None specified.

---

\*/ "Beverage" means soda water, carbonated natural or mineral water, or other nonalcoholic carbonated drinks; soft drinks, whether or not carbonated; beer, ale, or other malt drink of whatever alcoholic content; or a mixed wine drink or a mixed spirit drink.

† Denotes requirements that are consistent with the SPI Voluntary Code

**7. Additional Information:**

Department of Environment, Health and  
Natural Resources  
Post Office Box 27687  
Raleigh, North Carolina 27611  
(919) 733-4984

**8. Attachments:**

NC Gen. Stat. § 130A-309.10  
(Chapter 784, Senate Bill 111, § 130A-294.6  
attached)

GENERAL ASSEMBLY OF NORTH CAROLINA  
1989 SESSION  
RATIFIED BILL

CHAPTER 784  
SENATE BILL 111

AN ACT TO IMPROVE THE MANAGEMENT OF SOLID WASTE.

The General Assembly of North Carolina enacts:

**"§ 130A-309.10. Prohibited acts relating to packaging; coded labeling of plastic containers required; disposal of certain special wastes in landfills prohibited.**

(a) After 1 January 1990, no beverage shall be sold or offered for sale within the State in a beverage container designed and constructed so that the container is opened by detaching a metal ring or tab.

(b) After 1 October 1991, no person shall distribute, sell, or offer for sale in this State, any product packaged in a container or packing material manufactured with fully halogenated chlorofluorocarbons (CFC). Producers of containers or packing material manufactured with chlorofluorocarbons (CFC) are urged to introduce alternative packaging materials which are environmentally compatible.

(c) (1) After 1 January 1991, no plastic bag shall be provided at any retail outlet to any retail customer to use for the purpose of carrying items purchased by that customer unless the bag is composed of material which is recyclable. Notice of recyclability shall be printed on each bag.

(2) After 1 January 1993, no plastic bag shall be provided at any retail outlet to any retail customer to use for the purpose of carrying items purchased by that customer unless the Secretary certifies that not less than twenty-five percent (25%) of such bags are being recycled.

(d) (1) After 1 October 1991, no person shall distribute, sell, or offer for sale in this State any polystyrene foam product which is to be used in conjunction with food for human consumption unless such product is composed of material which is recyclable.

(2) After 1 October 1993, no person shall distribute, sell, or offer for sale in this State any polystyrene foam product which is to be used in conjunction with food for human consumption unless the Secretary certifies that not less than twenty-five percent (25%) of such products are being recycled.

(e) After 1 July 1991, no person shall distribute, sell, or offer for sale in this State any plastic container product unless the product has a molded label indicating the plastic resin used to produce the plastic container product. The code shall consist of a number placed within three triangulated arrows and letters placed below the triangulated arrows. The three arrows shall form an equilateral triangle with the common point of each line forming each angle of the triangle at the midpoint of each arrow and rounded with a short radius. The arrowhead of each arrow shall be at the midpoint of each side of the triangle with a short gap separating the arrowhead from the base of the adjacent arrow. The triangle formed by the three arrows curved at their midpoints shall depict a clockwise path around the code number. The label shall appear on the bottom of the plastic container product and be clearly visible. Plastic beverage containers having a capacity of less than 16 fluid ounces, nonsolid food liquid containers having a capacity of less than 16 fluid ounces, and rigid plastic

containers having a capacity of less than eight fluid ounces are exempt from the requirements of this subsection. The numbers and letters shall be as follows:

- (1) For polyethylene terephthalate, the letters 'PETE' and the number 1.
- (2) For high density polyethylene, the letters 'HDPE' and the number 2.
- (3) For vinyl, the letter 'V' and the number 3.
- (4) For low density polyethylene, the letters 'LDPE' and the number 4.
- (5) For polypropylene, the letters 'PP' and the number 5.
- (6) For polystyrene, the letters 'PS' and the number 6.
- (7) For any other, including multi-material containers, the letters 'OTHER' and the number 7.

(f) In accordance with the following schedule, no person shall knowingly dispose of the following special wastes in landfills:

- (1) Lead-acid batteries, after 1 January 1991. Lead-acid batteries also shall not be disposed of in any waste-to-energy facility after 1 January 1991. To encourage proper collection and recycling, all persons who sell lead-acid batteries at retail shall accept used lead-acid batteries as trade-ins for new lead-acid batteries.
- (2) Used oil, after 1 October 1990.
- (3) Yard trash, after 1 January 1993, except in landfills classified for such use under rules adopted by the Commission. Yard trash that is source separated from solid waste may be accepted at a solid waste disposal area where the area provides and maintains separate yard trash composting facilities.
- (4) White goods, after 1 January 1991.

(g) Prior to the effective dates specified in this section, the Department shall identify and assist in developing alternative disposal, processing, or recycling options for the solid waste identified in this section.



## TENNESSEE

1. **Compliance Date:** July 1, 1991
2. **Scope:** Plastic containers distributed, sold, or offered for sale in Tennessee:

<u>Type</u>	<u>Size</u>
<p><u>Rigid Plastic Containers</u> -- Formed or molded container, intended for single use, composed predominantly of plastic resin, relatively inflexible, finite shape.</p>	8 ounces to 5 gallons †
<p><u>Plastic Bottles</u> -- Plastic container with neck smaller than its body; accepts a screw-type, snap-cap, or other closure.</p>	16 ounces to 5 gallons †

3. **Required Codes:**

<u>Resin Type</u>	<u>Code Number</u> †	<u>Code Letters</u> †
Polyethylene Terephthalate	1	PETE
High Density Polyethylene	2	HDPE
Vinyl	3	V
Low Density Polyethylene	4	LDPE
Polypropylene	5	PP
Polystyrene	6	PS
Other	7	OTHER

A. Base cups and labels: No provision.

B. Multilayer: No provision.

4. **Required Symbol:** RIS; size not specified.
5. **Type and Location of Symbol:** Molded, imprinted, or raised symbol on or near the bottom of a plastic container or bottle.

† Denotes requirements that are consistent with the SPI Voluntary Code

6. **Penalties:** Warning, then \$50.

7. **Additional Information:**

Department of Health & Environment  
Cordell Hull Building, Room 347  
436 6th Avenue North  
Nashville, Tennessee 37219-5402  
(615) 741-3111

8. **Attachments:** Tenn. Code Ann. § 68-16-109 (1990)

† Denotes requirements that are consistent with the SPI Voluntary Code

# Tennessee Code Annotated

*1990 Supplement*

Updated through the 1990 Session of the General Assembly

**Volume 12A**

*1987 Replacement*

**THE OFFICIAL TENNESSEE CODE**

Prepared Under the Supervision of the  
Tennessee Code Commission

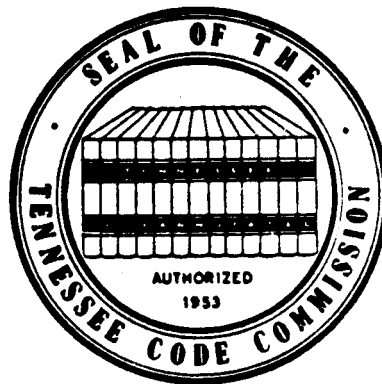

FRANK F. DROWOTA III, Chairman  
JAMES A. CLODFELTER, Executive Secretary  
WILLIAM J. HARBISON  
CHARLES W. BURSON  
CLETUS W. McWILLIAMS

**Cumulative pamphlet. Place in pocket of bound volume.  
Remove the 1989 pamphlet.**

**THE MICHIE COMPANY**  
*Law Publishers*  
CHARLOTTESVILLE, VIRGINIA  
1990

AUG 15 1990

(c) This section shall not apply to weather balloons which are used for the purpose of carrying scientific instruments during the performance of an experiment or testing procedure.

(d) The provisions of this section shall not apply to any county having a population, according to the 1980 federal census or any subsequent federal census of:

<u>not less than</u>	<u>nor more than</u>
24,600	24,700
28,500	28,560
28,690	28,750
49,275	49,375
51,025	51,125
58,075	58,175
770,000	780,000

[Acts 1990, ch. 792, §§ 1-6.]

**Effective Dates.** Acts 1990, ch. 792, § 8.  
January 1, 1991.

**68-16-109. Labeling of plastic containers.** — (a) As used in this section:

(1) "Container," unless otherwise specified, refers to "rigid plastic container" or "plastic bottle," as those terms are defined in this section;

(2) "Department" means the department of health and environment;

(3) "Label" means a molded, imprinted or raised symbol on or near the bottom of a plastic container or bottle;

(4) "Person" means an individual, sole proprietor, partnership, association, corporation or other legal entity;

(5) "Plastic" means any material made of polymeric organic compounds and additives that can be shaped by flow;

(6) "Plastic bottle" means a plastic container that has a neck that is smaller than the body of the container, accepts a screw-type, snap cap or other closure and has a capacity of sixteen (16) fluid ounces or more, but less than five (5) gallons; and

(7) "Rigid plastic container" means any formed or molded container, other than a bottle, intended for single use, composed predominantly of plastic resin, and having a relatively inflexible finite shape or form with a capacity of eight ounces (8 oz.) or more but less than five gallons (5 gal.).

(b)(1) The provisions of this section and any rules or regulations adopted hereunder shall be interpreted to conform with nationwide plastics industry standards.

(2) On or after July 1, 1991, no person shall distribute, sell or offer for sale in this state any plastic bottle or rigid plastic container unless such container is labeled with a code identifying the appropriate resin type used to produce the structure of the container. The code shall consist of a number placed within three (3) triangulated arrows and letters placed below the triangle of arrows. The triangulated arrows shall be equilateral, formed by three (3) arrows with the apex of each point of the triangle at the midpoint of each arrow, rounded with a short radius. The pointer (arrowhead) of each arrow

shall be at the midpoint of each side of the triangle with a short gap separating the pointer from the base of the adjacent arrow. The triangle, formed by the three (3) arrows curved at their midpoints shall depict a clockwise path around the code number. The numbers and letters used shall be as follows:

1. = PETE (polyethylene terephthalate)
2. = HDPE (high density polyethylene)
3. = V (vinyl)
4. = LDPE (low density polyethylene)
5. = PP (polypropylene)
6. = PS (polystyrene)
7. = OTHER

(3) The department shall maintain a list of the label codes provided in this subsection and shall provide a copy of that list to any person upon request.

(c) After being notified by the department that plastic containers were distributed, sold or offered for sale in this state not in compliance with the provisions of subsection (b), a person who, after receiving such notification from the department, distributes, sells or offers for sale in this state plastic containers which are not in compliance with the notification is subject to a civil penalty of fifty dollars (\$50.00) for violating such notification and may be enjoined from such violations. [Acts 1990, ch. 918, §§ 1-3.]

**Effective Dates.** Acts 1990, ch. 918, § 4.  
April 17, 1990.

## CHAPTER 17

### FIRE PREVENTION AND INVESTIGATION

**SECTION.**

68-17-143. Special deputy inspectors — Powers and duties — Inspection fees.

68-17-151. One-family or two-family rental

**SECTION.**

units — Smoke detectors required.

68-17-152. Warehouse storage of baled cotton.

**68-17-113. Regulations of state fire marshal — Subjects covered — Penalties.**

**Sentencing Reform Notes.** The penalty provided in this section was changed to a Class C misdemeanor on November 1, 1989. See Acts 1989, ch. 591, § 113, and §§ 40-35-110, 40-35-111.

Cited: Foster v. Bue, 749 S.W.2d 736 (Tenn. 1988).

**68-17-115. Cooperation of insurance companies and authorized fire officials in cases of suspected arson.**

#### NOTES TO DECISIONS

**1. Evidence.**

Malicious prosecution and outrageous conduct by insurer in investigation into suspected

arson held not shown. Smith v. Harford Mut. Ins. Co., 751 S.W.2d 140 (Tenn. Ct. App. 1987).

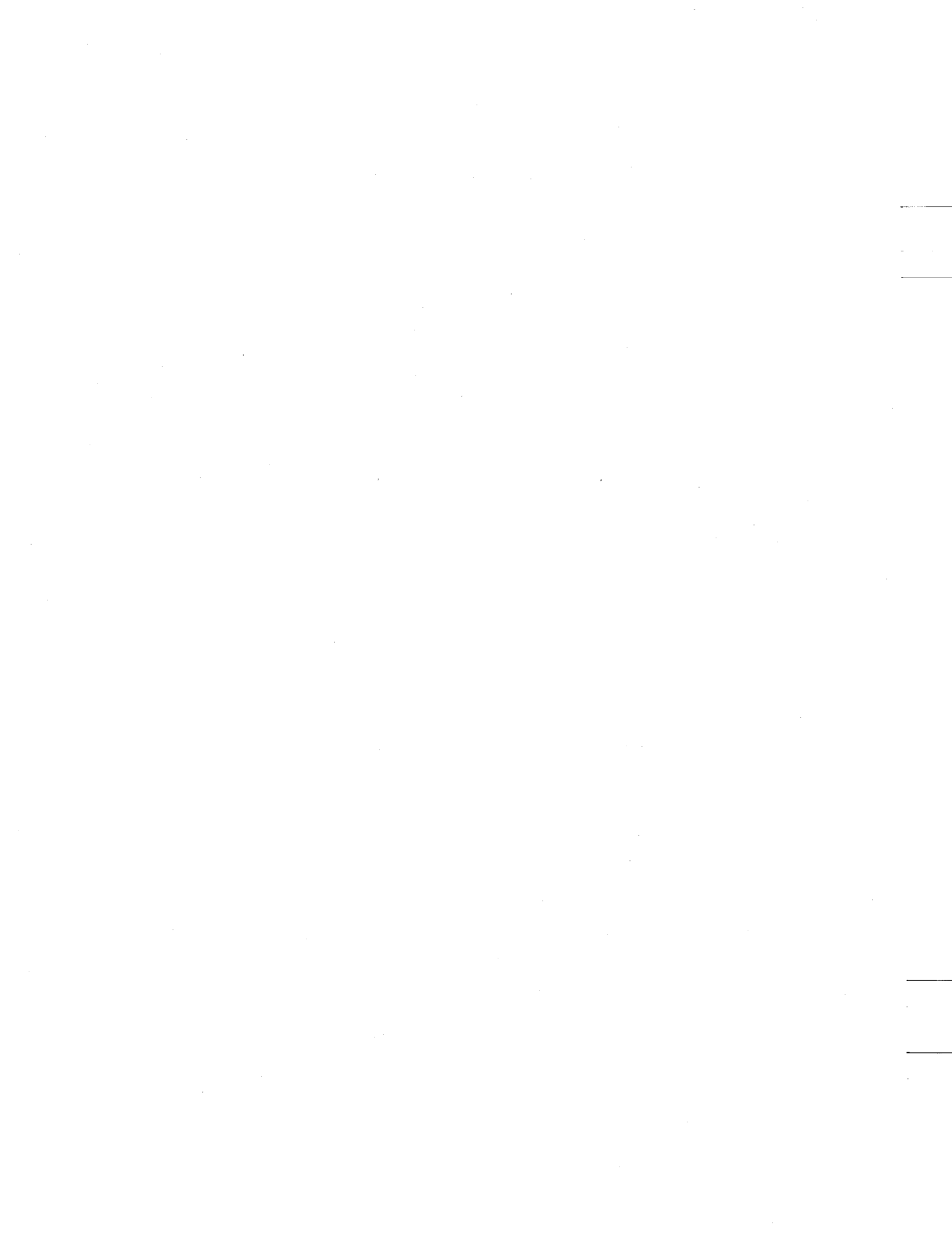

## VIRGINIA

1. **Compliance Date:** July 1, 1992
2. **Scope:** Plastic containers sold, exposed for sale, or distributed in Virginia:

<u>Type</u>	<u>Size</u>
<p><u>Rigid Plastic Containers</u> -- Formed or molded container, intended for single use, composed predominantly of plastic resin, relatively inflexible, finite shape.</p>	8 ounces to 5 gallons †
<p><u>Plastic Bottles</u> -- Plastic container intended for single use; has a neck smaller than the container; accepts a screw-type, snap cap, or other closure.</p>	16 ounces to 5 gallons †

3. **Required Codes:**

<u>Resin Type</u>	<u>Code Number</u> †	<u>Code Letters</u> †
Polyethylene Terephthalate	1	PETE
High Density Polyethylene	2	HDPE
Vinyl	3	V
Low Density Polyethylene	4	LDPE
Polypropylene	5	PP
Polystyrene	6	PS
Other	7	OTHER

- A. Base cups and labels: No provision. †
- B. Multilayer: No provision.

4. **Required Symbol:** RIS; size not specified.
5. **Type and Location of Symbol:** Clearly visible, on or near the bottom of the container.

† Denotes requirements that are consistent with the SPI Voluntary Code

6. **Penalties:** \$50, with each day of violation constituting a separate offense.

7. **Additional Information:**

Council on the Environment  
Department of Waste Management,  
Recycling, Litter Control  
202 N. 9th Street, Room 903  
Richmond, Virginia 23219  
(804) 371-0044

8. **Attachments:** Code of Virginia § 10.1-1415.1

† Denotes requirements that are consistent with the SPI Voluntary Code



**1990 SESSION**  
**VIRGINIA ACTS OF ASSEMBLY - CHAPTER 9**

*An Act to amend the Code of Virginia by adding a section numbered 10.1-1415.1, relating to the labeling of plastic container products; penalty.*

[H 854]

Approved APR 4 1990

Be it enacted by the General Assembly of Virginia:

1. That the Code of Virginia is amended by adding a section numbered 10.1-1415.1 as follows:

*§ 10.1-1415.1. Labeling of plastic container products required; penalty.—A. It shall be unlawful for any person to sell, expose for sale, or distribute any plastic bottle or rigid plastic container unless the container is labeled indicating the plastic resin used to produce the container. Such label shall appear on or near the bottom of the container, be clearly visible, and consist of a number placed within three triangulated arrows and letters placed below the triangle of arrows. The triangulated arrows shall be equilateral, formed by three arrows with the apex of each point of the triangle at the midpoint of each arrow, rounded with a short radius. The pointer (arrowhead) of each arrow shall be at the midpoint of each side of the triangle with a short gap separating the pointer from the base of the adjacent arrow. The triangle, formed by three arrows curved at their midpoints, shall depict a clockwise path around the code number. The numbers and letters shall be as follows:*

- 1. For polyethylene terephthalate, the letters "PETE" and the number 1.*
- 2. For high density polyethylene, the letters "HDPE" and the number 2.*
- 3. For vinyl, the letter "V" and the number 3.*
- 4. For low density polyethylene, the letters "LDPE" and the number 4.*
- 5. For polypropylene, the letters "PP" and the number 5.*
- 6. For polystyrene, the letters "PS" and the number 6.*
- 7. For any other plastic resin, the letters "OTHER" and the number 7.*

*B. As used in subsection A of this section:*

*"Container," unless otherwise specified, refers to "rigid plastic container" or "plastic bottle" as those terms are defined below.*

*"Plastic bottle" means a plastic container intended for single use that has a neck that is smaller than the container, accepts a screw-type, snap cap or other closure and has a capacity of sixteen fluid ounces or more but less than five gallons.*

*"Rigid plastic container" means any formed or molded container, other than a bottle, intended for single use, composed predominantly of plastic resin, and having a relatively inflexible finite shape or form with a capacity of eight ounces or more but less than five gallons.*

*C. Any person convicted of a violation of the provisions of subsection A of this section shall be punished by a fine of not more than fifty dollars. Each day of violation shall constitute a separate offense.*

2. That the provisions of this section shall become effective July 1, 1992.

---

**President of the Senate**

---

**Speaker of the House of Delegates**

**Approved:**

---

**Governor**

## Mid Western Region

Illinois, Indiana, Iowa, Michigan, Minnesota,  
Missouri, North Dakota, Ohio, Wisconsin

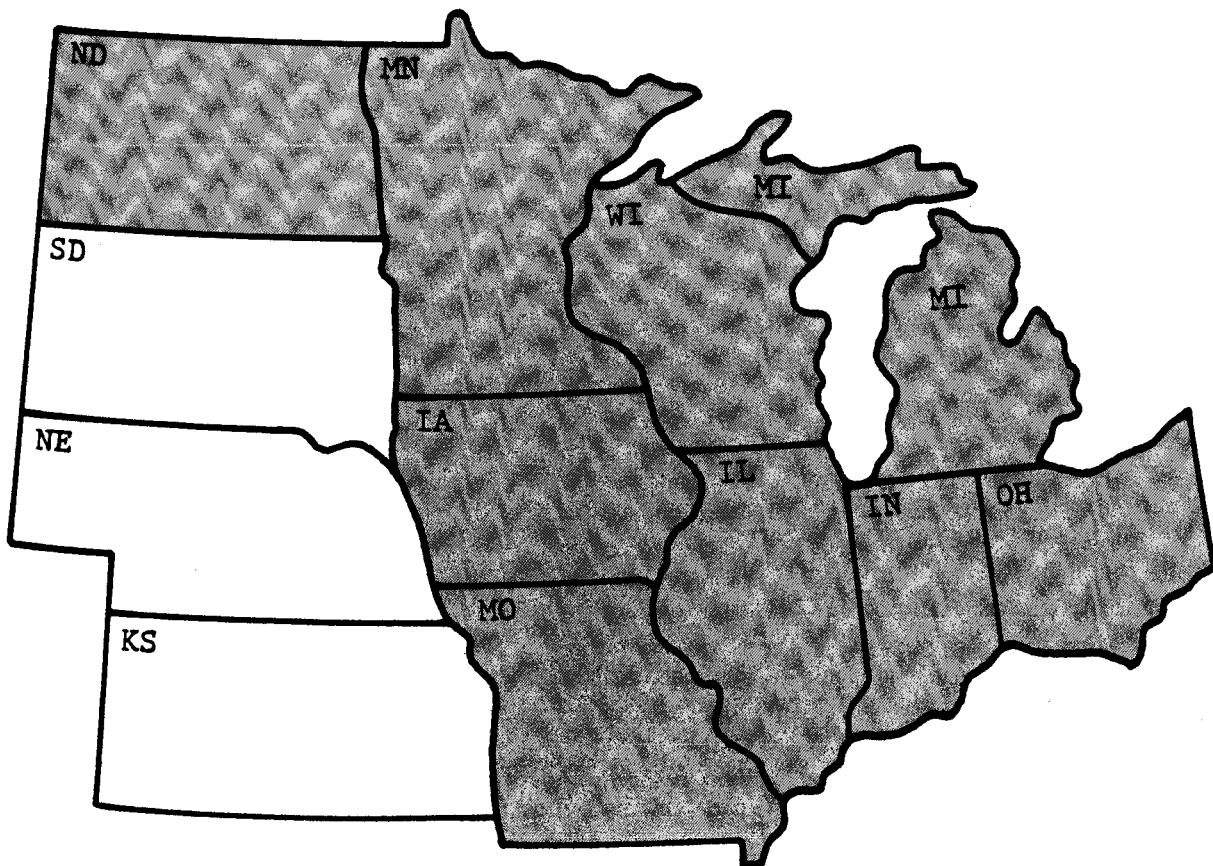



## ILLINOIS

1. **Compliance Date:** January 1, 1991
2. **Scope:** Plastic bottles and plastic containers (not limited to thermoplastics) that are manufactured for use in Illinois.

<u>Type</u>	<u>Size</u>
<u>Plastic Bottles</u>	16 ounces or more †
<u>Rigid Plastic Containers</u>	8 ounces or more †

3. **Required Codes:**

<u>Resin Type</u>	<u>Code Number</u> †	<u>Code Letters</u> †
Polyethylene Terephthalate	1	PETE
High Density Polyethylene	2	HDPE
Vinyl	3	V
Low Density Polyethylene	4	LDPE
Polypropylene	5	PP
Polystyrene	6	PS
Other	7	OTHER

- A. Base cups: Containers with base cups or labels of different material should be coded by their primary, basic material. †
- B. Multilayer: Include as "7-OTHER."

4. **Required Symbol:** RIS; Size not specified. †
5. **Type and Location of Code:** Not specified. †
6. **Penalties:** Civil penalty not to exceed \$5,000 per violation where a violation is defined as causing (or assisting in) a violation of the resin coding requirement. State's Attorney or any person of the county in which the violation occurred, or the Attorney General at the request of an Agency or on his own may institute the civil action.

† Denotes requirements that are consistent with the SPI Voluntary Code

**7. Additional Information:**

Mr. George Logan  
[Illinois] Environmental Protection Agency  
325 West Adams Street  
Room 300  
Springfield, Illinois 62706  
(217) 785-2800

**8. Attachment:**

ILL. ANN. STAT. ch. 85, ¶5960 (Smith-Hurd  
1989), January 1, 1989

Technical Amendment: Public Act 86-177

(b) The Department shall establish guidelines for solicitation of grants under this Section. Applications for assistance shall be filed with the Department on forms provided by the Department and shall set forth such information as may be required by the Department. The Department shall evaluate the application and notify the applicant of the qualification or non-qualification of the application within 45 days of the deadline established by the Department for receipt of applications.

(c) In implementing this Section, the Department shall, pursuant to appropriation, make grants from the Solid Waste Management Fund to municipalities with approved pilot recycling projects. Such grants shall be limited to 50% of the project costs, not to exceed a total of \$50,000 per project.

(d) No more than 25 pilot recycling project grants may be made pursuant to this Section.

P.A. 85-1198, § 8, eff. Jan. 1, 1989.

#### 5959. Disposal of leaves—Sanitary landfills

§ 9. Beginning September 1, 1989, no sanitary landfill in the State may accept for final disposal at any time truckloads composed primarily of leaves, except that leaves separated at the source from other municipal waste may be accepted by a sanitary landfill facility in those instances where the facility has provided and maintains for that purpose separate composting facilities, and the composted leaves are utilized either as part of the final vegetative cover for the landfill, or for other uses as a soil conditioning material.

P.A. 85-1198, § 9, eff. Jan. 1, 1989.

#### 5960. Plastic containers—Coding

§ 10. (a) Beginning January 1, 1991, all plastic bottles with a capacity of 16 fluid ounces or more and all other rigid plastic containers with a capacity of 8 fluid ounces or more that are manufactured for use in this State shall be coded in a manner that assists recyclers in sorting such containers by resin composition. The code shall consist of a 3-sided triangular arrow with a number in the center and letters underneath. The number and letters shall indicate the resin from which the container is made as follows: 1 and PET for polyethylene terephthalate, 2 and HDPE for high density polyethylene, 3 and V for vinyl, 4 and LDPE for low density polyethylene, 5 and PP for polypropylene, 6 and PS for polystyrene, and 7 and Other for other materials, including multi-layer materials. Containers with labels or base cups of different material shall be coded by their primary, basic material.

P.A. 85-1198, § 10, eff. Jan. 1, 1989.

#### 5961. Violations

§ 11. (a) It shall be a violation of this Act for any person:

(1) To cause or assist in the violation of Section 9 or 10 of this Act<sup>1</sup> or any regulation promulgated hereunder.

(2) To fail to adhere to the schedule set forth in, or pursuant to, this Act for adopting and reviewing a waste management plan.

(3) To fail to implement the recycling component of an adopted waste management plan.

P.A. 85-1198, § 11, eff. Jan. 1, 1989.

<sup>1</sup> Paragraph 5959 or 5960 of this chapter.

#### 5962. Civil penalty

§ 12. (a) Any person that violates any provision of this Act shall be liable for a civil penalty not to exceed \$5,000 for such violation; such penalty may, upon order of a court of competent jurisdiction, be made payable to the Solid Waste Management Fund, to be used in accordance with the provisions of the Illinois Solid Waste Management Act.<sup>1</sup>

(b) The State's Attorney or any person of the county in which the violation occurred, or the Attorney General, at the request of the Agency or on his own

motion, may institute a civil action against any violator of this Act. The court may award costs and reasonable attorney fees to the State's Attorney, Attorney General, or any person who has prevailed against a person who has committed a willful, knowing or repeated violation of this Act.

(c) Any funds collected under subsection (b) in which the Attorney General has prevailed shall be deposited in the Solid Waste Management Fund.

P.A. 85-1198, § 12, eff. Jan. 1, 1989.

1 Chapter 111½, § 7051 et seq.

SPORTS FACILITIES AUTHORITY ACT

6001. Short title

§ 1. This Act shall be known and may be cited as the "Illinois Sports Facilities Authority Act".

P.A. 84-1470, § 1, eff. July 1, 1987.

Historical Note

P.A. 84-1470, § 1, approved Jan. 20, 1987, eff. July 1, 1987.

Title of Act:

An Act to create the Illinois Sports Facilities Authority, amending certain Acts therein named.

6002. Definitions—General provisions

§ 2. Definitions—general provisions. In this Act the following words have the meanings indicated:

(A) "Authority" means the Illinois Sports Facilities Authority.

(B) "Facility" means:

(1) Stadiums, arenas or other structures for the holding of athletic contests or events, including baseball, football and automobile racing; musical, dramatic and other artistic, or social events; and

(2) Practice fields, or other areas where professional sports teams may practice or perform.

(3) "Facility" also means the following types of property if that property is directly related to an item listed in paragraphs (1) through (2) of subsection (B) of this Section:

(i) Offices, parking lots and garages, access roads, transportation facilities, restaurants and stores;

(ii) Other recreation areas; and

(iii) Other property or structures including all fixtures, furnishings, and appurtenances normally associated with such facilities.

(C) "Management Agreement" means a legally binding contract between the Authority and a tenant of the facility which contains at least the following provisions:

(1) a provision requiring the tenant to conduct its complete regular home season schedule and any home playoff events in the facility;

(2) a provision requiring the tenant to provide routine maintenance of and to operate the facility with its personnel or contractors;

(3) a provision requiring the tenant to advertise and promote events it conducts at the facility;

(4) a provision requiring the tenant to operate or contract for concessions for the patrons of the facility, including a stadium club and restaurant where food and beverages will be served;



## INDIANA

1. **Compliance Date:** January 1, 1992
2. **Scope:** Plastic bottles and plastic containers (not limited to thermoplastics) sold in Indiana:

<u>Type</u>	<u>Size</u>
<u>Plastic Bottles</u>	16 ounces or more †
<u>Rigid Plastic Containers</u>	8 ounces or more †

3. **Required Codes:**

<u>Resin Type</u>	<u>Code Number</u> †	<u>Code Letters</u> †
Polyethylene Terephthalate	1	PETE
High Density Polyethylene	2	HDPE
Vinyl	3	V
Low Density Polyethylene	4	LDPE
Polypropylene	5	PP
Polystyrene	6	PS
Other	7	OTHER

A. Base cups and labels: A bottle or other container with a label or base cup made of a different material than the rest of the container must be coded according to its primary, basic material. †

B. Multilayer: Include as "7-OTHER."

4. **Required Symbol:** RIS; Size not specified. †
5. **Type and Location of Code:** Not specified.
6. **Penalties:** None specified.

† Denotes requirements that are consistent with the SPI Voluntary Code

**7. Additional Information:**

Ms. Mary A. Swindler  
Office of Solid and Hazardous Waste  
Management  
105 South Meridian St.  
Indianapolis, Indiana 46225  
(317) 232-8883

**8. Attachment:** IND. CODE ANN. §13-7-22-1 (West),  
May 31, 1989

## ENVIRONMENT

13-7-22-1

(c) The department shall grant operating authority under a permit issued by the department only after the owner of the incinerator has:

- (1) complied with all construction and pre-operational standards established by pertinent rules; and
- (2) submitted the results of a pre-operational emissions test which demonstrate that the incinerator's performance complies with all pertinent rules.

(d) The pre-operational emissions test required by this section shall be conducted under the supervision of the department. In addition, the report of the results of the pre-operational emissions test must contain a certification that the test was performed in compliance with:

- (1) all pertinent rules; and
- (2) the pre-operational emissions test plan submitted with the permit application.

*As added by P.L.168-1987, SEC.6.*

## 13-7-21-6 Permit provisions

Sec. 6. (a) A permit issued under this chapter for the operation of an incinerator must include:

(1) a provision requiring the permit holder to notify the department and appropriate local government officials of:

- (A) any release of a contaminant in a quantity exceeding a control level established under section 3 of this chapter;
- (B) any violation of operating requirements established in the permit;
- (C) any unscheduled shutdown of the incinerator or associated equipment;
- (D) any damage to the incinerator or associated equipment that could, if unrepaired, result in a release of a contaminant in a quantity exceeding a control level established under section 3 of this chapter; and

(2) a provision requiring that the notification be given within twenty-four (24) hours after the permit holder learns of the release, violation, shutdown, or damage.

*As added by P.L.168-1987, SEC.6.*

## 13-7-21-7 Enforcement of chapter; penalties

Sec. 7. (a) This chapter shall be enforced under IC 13-7-11.

(b) Violations of this chapter or of any rules adopted under this chapter are subject to the penalties set forth in IC 13-7-13. *As added by P.L.168-1987, SEC.6.*

## 13-7-21-8 Incinerators operated as hazardous waste facility; applicability of provisions

Sec. 8. A permit is not required under this chapter for the incineration of a solid waste in an incinerator operated as a hazardous waste facility under IC 13-7-8.5 if the permit issued for the incinerator under IC 13-7-8.5 authorizes the incineration of the solid waste in the incinerator. *As added by P.L.168-1987, SEC.6.*

## Chapter 22. Miscellaneous Solid Waste Provisions.

## Section

13-7-22-1 Plastic bottles and containers; recycling coding

## 13-7-22-1 Plastic bottles and containers; recycling coding

Sec. 1. (a) Beginning January 1, 1992, a person may not sell in Indiana any:

- (1) plastic bottle with a capacity of sixteen (16) fluid ounces or more; or
- (2) rigid plastic container with a capacity of eight (8) fluid ounces or more;

T. 13 Ind. Code—11  
1988 P.P.

309

unless the bottle or container is coded as required under subsection (b) to assist recyclers in sorting the bottle or container by resin composition.

(b) Each bottle and plastic container described in subsection (a) must be coded. The coding must consist of a three (3) sided triangular arrow with a number in the center and letters underneath. The number and letters must indicate the resin from which the container is made as follows:

- (1) One (1) and "PETE" for polyethylene terephthalate.
- (2) Two (2) and "HDPE" for high density polyethylene.
- (3) Three (3) and "V" for vinyl.
- (4) Four (4) and "LDPE" for low density polyethylene.
- (5) Five (5) and "PP" for polypropylene.
- (6) Six (6) and "PS" for polystyrene.
- (7) Seven (7) and "Other" for other materials, including multi-layer materials.

(c) A bottle or other container with a label or base cup made of a different material than the rest of the container must be coded according to its primary, basic material. As added by P.L.165-1989, SEC.1.

## IOWA

1. **Compliance Date:** July 1, 1992
2. **Scope:** Plastic bottles and plastic containers that can be shaped by flow distributed, sold or offered for sale in Iowa:

<u>Type</u>	<u>Size</u>
<p><u>Plastic Bottles</u> -- Container with neck smaller than its body and accepts a closure.</p>	<p>16 ounces to 5 gallons †</p>
<p><u>Rigid Plastic Containers</u> -- Other than bottle; intended for single use; relatively inflexible infinite [sic] shape.</p>	<p>8 ounces to 5 gallons †</p>

3. **Required Codes:**

<u>Resin Type</u>	<u>Code Number</u> †	<u>Code Letters</u> †
Polyethylene Terephthalate	1	PETE
High Density Polyethylene	2	HDPE
Vinyl	3	V
Low Density Polyethylene	4	LDPE
Polypropylene	5	PP
Polystyrene	6	PS
Other	7	OTHER

- A. Base cups and labels: Rigid plastic bottles or rigid plastic containers with labels and base cups of a different material shall be coded by their basic material. †
- B. Multilayer: Include as "7-OTHER."

4. **Required Symbol:** RIS; Size not specified. †
5. **Type and Location of Code:** Molded imprint or raised symbol on or near the bottom of the bottle or container.

† Denotes requirements that are consistent with the SPI Voluntary Code

6. **Penalties:** Civil penalty of not more than \$500 per each violation for a container manufacturer or distributor who violates this law.

7. **Additional Information:**

Department of Environmental Quality  
3920 Delaware Avenue  
Des Moines, Iowa 50319  
(515) 281-8690

Mr. Robert Meddaugh  
State Recycling Coordinator  
Department of National Resources  
900 East Grand Avenue  
Des Moines, Iowa 50319  
(515) 281-8176

8. **Attachments:** 1989 Iowa Act Ch. 272 Section 12  
(H.F. 753 attached)

## H.F. 753 1989 REGULAR SESSION

NO. 279

Sec. 12. NEW SECTION.**455D.12. Plastic container labeling**

1. In this section unless the context otherwise requires:
  - a. "Label" means a molded imprint or raised symbol on or near the bottom of a plastic product.
  - b. "Plastic" means any material made of polymeric organic compounds and additives that can be shaped by flow.
  - c. "Plastic bottle" means a plastic container that has a neck that is smaller than the body of the container, accepts a screw-type, snap cap, or other closure, and has a capacity of sixteen fluid ounces or more, but less than five gallons.
  - d. "Rigid plastic container" means any formed or molded container, other than a bottle, intended for single use, composed predominantly of plastic resin, and having a relatively inflexible infinite shape or form with a capacity of eight ounces or more, but less than five gallons.
2. Beginning July 1, 1992, a person shall not distribute, sell, or offer for sale in this state a plastic bottle or rigid plastic container unless the product is labeled with a code indicating the plastic resin used to produce the bottle or container. Rigid plastic bottles or rigid plastic containers with labels and basecaps of a different material shall be coded by their basic material. The code shall consist of a number placed within a triangle of arrows and letters placed below the triangle of arrows. The triangle shall be equilateral, formed by three arrows with the apex of each point of the triangle at the midpoint of each arrow, rounded with a short radius. The arrowhead of each arrow shall be at the midpoint of each side of the triangle with a short gap separating the pointer from the base of the adjacent arrow. The triangle, formed by the three arrows curved at their midpoints, shall depict a clockwise path around the code number. The numbers and letters used shall be as follows:
  - a. 1. -PETE (polyethylene terephthalate)
  - b. 2. -HDPE (high density polyethylene)
  - c. 3. -V (vinyl)
  - d. 4. -LDPE (low density polyethylene)
  - e. 5. -PP (polypropylene)
  - f. 6. -PS (polystyrene)
  - g. 7. -OTHER (includes multi-layer)
3. The department shall maintain a list of the label codes provided in subsection 2 and shall provide a copy of that list to any person upon request.
4. A container manufacturer or distributor who violates this section is subject to a civil penalty of not more than five hundred dollars for each violation.

Sec. 13. NEW SECTION.**455D.13. Land disposal of waste oil prohibited—collection**

1. A sanitary landfill shall not accept waste oil for final disposal beginning July 1, 1990.
2. A person offering for sale or selling oil at retail in the state shall do the following:
  - a. Accept at the point of sale, waste oil from customers, or post notice of locations where a customer may dispose of waste oil.
  - b. Post written notice that it is unlawful to dispose of waste oil in a sanitary landfill.

Sec. 14. NEW SECTION.Additions in existing text are indicated by underline; deletions by ~~strikeouts~~

665





## MICHIGAN

1. **Compliance Date:** January 1, 1992
2. **Scope:** Plastic bottles and containers that can be shaped by flow sold in Michigan:

<u>Type</u>	<u>Size</u>
<u>Plastic Bottles</u> -- Container with neck smaller than its body and accepts a closure.	16 ounces to 5 gallons †
<u>Rigid Plastic Containers</u> -- Other than bottle; intended for single use; relatively inflexible finite shape.	8 ounces to 5 gallons †

3. **Required Codes:**

<u>Resin Type</u>	<u>Code Number</u>	<u>Code Letters</u>
Polyethylene Terephthalate	1 †	PETE † */
High Density Polyethylene	2 †	HDPE †
Vinyl	3 †	V †
Low Density Polyethylene	4 †	LDPE †
Polypropylene	5 †	PP †
Polystyrene	6 †	PS †
Multilayer	7 †	OTHER †
Degradable	8	D

- A. Base cups and labels: Not Applicable. †
- B. Multilayer: Defined as "7-OTHER."
- C. Degradable: Capable of being broken down by biodegradation, photodegradation, or chemical degradation into component parts within 360 days under exposure to the elements.

---

\*/ June 1989 amendment changed "PETt" to "PETE."

† Denotes requirements that are consistent with the SPI Voluntary Code

PLASTIC CONTAINER CODING SUMMARY

4. **Required Symbol:** RIS; Triangle not less than 1/2" high.
5. **Type and Location of Code:** Molded imprint or raised symbol on or near the bottom of the bottle or container.
6. **Penalties:** A person who violates this act is subject to a civil fine of \$500 per violation.
7. **Additional Information:**

Mr. Wayne Koser  
Department of Natural Resources  
Waste Management Division  
P. O. Box 30624  
Lansing, Michigan 48909  
(517) 373-4741

8. **Attachments:** MICH. STAT. ANN. §§13.28(81)-13.28(84),  
December 27, 1988  
Amendment: H.B. No. 4711

1988 Session

88 PA 414

ing recycled scrap metals, that contain 1 or more of the following in a percentage as determined by the department as provided by law:

- (a) Waste materials generated by a business or a consumer.
  - (b) Materials that have served their intended purpose.
  - (c) Materials that have been separated from solid waste for purposes of collection, recycling, and disposition.
- (MCL §18.1261a.)

History. Added by Pub Acts 1988, No. 413, eff —.

[PUBLIC ACT NO. 414]

PLASTIC PRODUCT LABELING ACT

Act 414 of 1988

SEC.

- 13.28(81) Definitions.
- 13.28(82) Plastic products; label required.  
List of label codes; copies of list.
- 13.28(83) Additional staff prohibited.
- 13.28(84) Violation; civil fine.  
Default in payment; remedy.

PLASTIC PRODUCT LABELING ACT

Act 414, 1988, p —; imd eff December 27.

AN ACT to require the labeling of certain plastic products; to provide for the powers and duties of certain state departments and officials; and to prescribe penalties and remedies.

*The People of the State of Michigan enact:*

§ 13.28(81) Definitions.] Sec. 1. As used in this act:

- (a) "Degradable" means capable of being broken down by biodegradation, photodegradation, or chemical degradation into component parts within 360 days under exposure to the elements.
- (b) "Department" means the department of natural resources.
- (c) "Label" means a molded imprint or raised symbol on or near the bottom of a plastic product.
- (d) "Person" means an individual, sole proprietor, partnership, association, corporation, or other legal entity.
- (e) "Plastic" means any material made of polymeric organic compounds and additives that can be shaped by flow.
- (f) "Plastic bottle" means a rigid plastic container with a capacity of 16 ounces or more that has a neck that is smaller than the body of the container.
- (g) "Plastic product" means a plastic bottle and any other rigid plastic container.
- (h) "Rigid plastic container" means any container composed predominantly of plastic resin and having a relatively inflexible finite

88:1367

shape or form that directly holds a substance or material and has a capacity of 8 ounces or more.

- (i) "PETt" means polyethylene terephthalate.
  - (j) "HDPE" means high density polyethylene.
  - (k) "V" means vinyl.
  - (l) "LDPE" means low density polyethylene.
  - (m) "PP" means polypropylene.
  - (n) "PS" means polystyrene.
  - (o) "OTHER" means multi-layer.
  - (p) "D" means degradable.
- (MCL §99.481.)

**§ 13.28(82) Plastic products; label required.] Sec. 2. (1)** On or after January 1, 1992, all plastic products sold in this state shall have a label indicating the plastic resin used to produce the product. The label shall consist of a number placed inside a triangle and letters placed immediately below the triangle. The numbers and letters used on the label shall be not less than 1/2 inch high and shall appear on the bottom of the plastic product as follows:

- (a) 1 PETt.
- (b) 2 HDPE.
- (c) 3 V.
- (d) 4 LDPE.
- (e) 5 PP.
- (f) 6 PS.
- (g) 7 OTHER.
- (h) 8 D.

**List of label codes; copies of list.] (2)** The department shall maintain a list of the label code provided in subsection (1) and shall provide a copy of that list to any person upon request. (MCL §99.482.)

**§ 13.28(83) Additional staff prohibited.] Sec. 3.** No additional staff shall be hired by the department for the purposes of enforcing this act. (MCL §99.483.)

**§ 13.28(84) Violation; civil fine.] Sec. 4. (1)** A person who violates this act is subject to a civil fine of \$500.00 per violation.

**Default in payment; remedy.] (2)** A default in the payment of a civil fine ordered under this act may be remedied by any means authorized under the revised judicature act of 1961, Act No. 236 of the Public Acts of 1961, being sections 600.101 to 600.9947 of the Michigan Compiled Laws. (MCL §99.484.)

**Statutory references.** Act No. 236 of 1961, above referred to, is §27A.101 et seq., *infra*.

Act No. 63  
Public Acts of 1989  
Approved by the Governor  
June 15, 1989  
Filed with the Secretary of State  
June 16, 1989

**STATE OF MICHIGAN  
85TH LEGISLATURE  
REGULAR SESSION OF 1989**

Introduced by Rep. Kosteva

# ENROLLED HOUSE BILL No. 4711

AN ACT to amend sections 1 and 2 of Act No. 414 of the Public Acts of 1988, entitled "An act to require the labeling of certain plastic products; to provide for the powers and duties of certain state departments and officials; and to prescribe penalties and remedies," being sections 299.481 and 299.482 of the Michigan Compiled Laws.

*The People of the State of Michigan enact:*

Section 1. Sections 1 and 2 of Act No. 414 of the Public Acts of 1988, being sections 299.481 and 299.482 of the Michigan Compiled Laws, are amended to read as follows:

Sec. 1. As used in this act:

- (a) "Degradable" means capable of being broken down by biodegradation, photodegradation, or chemical degradation into component parts within 360 days under exposure to the elements.
- (b) "Department" means the department of natural resources.
- (c) "Label" means a molded, imprinted, or raised symbol on or near the bottom of a plastic product.
- (d) "Person" means an individual, sole proprietor, partnership, association, corporation, or other legal entity.
- (e) "Plastic" means any material made of polymeric organic compounds and additives that can be shaped by flow.
- (f) "Plastic bottle" means a rigid plastic container with a capacity of 16 ounces or more that has a neck that is smaller than the body of the container.
- (g) "Plastic product" means a plastic bottle and any other rigid plastic container.
- (h) "Rigid plastic container" means any container composed predominantly of plastic resin and having a relatively inflexible finite shape or form that directly holds a substance or material and has a capacity of 8 ounces or more.
- (i) "PETE" means polyethylene terephthalate.
- (j) "HDPE" means high density polyethylene.
- (k) "V" means vinyl.
- (l) "LDPE" means low density polyethylene.
- (m) "PP" means polypropylene.
- (n) "PS" means polystyrene.
- (o) "OTHER" means multi-layer.
- (p) "D" means degradable.

Sec. 2. (1) On or after January 1, 1992, all plastic products sold in this state shall be labeled with a code indicating the plastic resin used to produce the product. The code shall consist of a number placed within a triangle of arrows with letters placed below the triangle of arrows. The triangle shall be equilateral, formed by 3 arrows with the apex of each point of the triangle at the midpoint of each arrow, rounded with a short radius. The pointer or arrowhead of each arrow shall be at the midpoint of each side of the triangle with a short gap separating the pointer from the base of the adjacent arrow. The triangle, formed by the 3 arrows curved at their midpoints shall depict a clockwise path around the code number. The triangle of arrows shall be not less than 1/2 inch high or if the plastic product is designed so that a triangle or arrows of not less than 1/2 inch height cannot be added to the product, a smaller label may be used if the label can be easily read. The code shall appear on or near the bottom of the plastic product as follows:

- (a) 1 PETE.
- (b) 2 HDPE.
- (c) 3 V.
- (d) 4 LDPE.
- (e) 5 PP.
- (f) 6 PS.
- (g) 7 OTHER.
- (h) 8 D.

(2) The department shall maintain a list of the label code provided in subsection (1) and shall provide a copy of that list to any person upon request.

This act is ordered to take immediate effect.

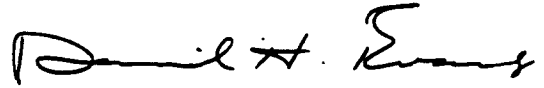

.....  
Clerk of the House of Representatives.

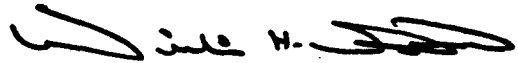

.....  
Secretary of the Senate.

Approved.....

.....  
Governor.

## MINNESOTA

1. **Compliance Date:** Upon promulgation of regulations which were to have been adopted by March 31, 1989, but have still not been finalized.
2. **Scope:** Plastic containers (not limited to thermoplastics) with a capacity of 16 ounces or greater manufactured or brought into the state for sale in Minnesota.

Type

Size

Plastic Container -- individual, 16 ounces or more  
separate plastic bottle, can,  
or jar.

3. **Required Codes:**

To be established by rules "as consistent as practicable with national industry wide plastic container coding systems."

4. **Required Symbol:** None.

5. **Penalties:** After notification of non-compliance, manufacturers and distributors are subject to a civil penalty of \$50 for each violation up to a maximum of \$500 and may be enjoined from such violations.

6. **Additional Information:**

Mr. Tim Nolan  
Minnesota Office of Waste Management  
1350 Energy Lane  
St. Paul, Minnesota 55108  
612-649-5750

7. **Attachment:** Minnesota Stat. Ann. § 325E.044

## REGULATION OF TRADE PRACTICES

## § 325E.042

**325E.026. Unauthorized use of utility meters**

**Subdivision 1. Definitions.** When used in this section, the terms defined in section 216B.02 have the same meanings. Other terms used in this section have the following meanings:

(a) "Bypassing" means the act of attaching, connecting, or otherwise affixing a wire, cord, socket, pipe, hose, motor, or other instrument or device to utility or customer-owned facilities or equipment so that service provided by the utility is transmitted, supplied, or used without passing through a meter authorized by the utility for measuring or registering the amount of service provided.

(b) "Tampering" means damaging, altering, adjusting, or obstructing the operation of a meter or submeter provided by a utility for measuring or registering the amount of electricity, natural gas, or other utility service passing through the meter.

(c) "Unauthorized connection" means the physical connection or physical reconnection of utility service by a person without the authorization or consent of the utility.

(d) "Unauthorized metering" means removing, installing, connecting, reconnecting, or disconnecting a meter, submeter, or metering device for service by a utility, by a person other than an authorized employee or agent of the utility.

(e) "Utility" means a public utility defined in section 216B.02, subdivision 4; a municipal utility; or a cooperative electric association organized under chapter 308.

**Subd. 2. Civil actions; remedies.** A utility may bring a civil action for damages against a person who: (1) deliberately commits, authorizes, attempts, solicits, aids, or abets bypassing, tampering, unauthorized connection, or unauthorized metering that results in damages to the utility; or (2) knowingly receives service provided as a result of bypassing, tampering, unauthorized connection, or unauthorized metering. The utility may recover double the costs of the service provided; the costs and expenses for investigation, disconnection, reconnection, service calls, equipment, and employees; and the trial costs and witness fees.

**Subd. 3. Damages to benefit ratepayers.** Damages recovered under this section in excess of the actual damages sustained by a public utility regulated by the commission must be taken into account by the commission and applied for the benefit of the public utility's ratepayers in establishing utility rates.

**Subd. 4. Additional remedies.** The remedies provided in this section are supplemental and additional to other remedies or powers conferred by law and not in limitation of other civil or criminal statutory or common law remedies.

Laws 1987, c. 272, § 1.

## SALE AND LABELING OF PLASTICS [NEW]

**325E.042. Prohibiting sale of certain plastics**

**Subdivision 1. Plastic can.** (a) A person may not sell, offer for sale, or give to consumers in this state a beverage packaged in a plastic can.

(b) A plastic can subject to this subdivision is a single serving beverage container composed of plastic and metal excluding the closure mechanism.

**Subd. 2. Nondegradable plastic.** A person may not sell, offer for sale, or give to consumers beverages or motor oil containers held together by nondegradable plastic material.

*Text of subd. 2 effective July 1, 1989.*

**Subd. 3. Penalty.** A person who violates subdivision 1 or 2 is guilty of a misdemeanor.

Laws 1988, c. 685, § 26.



## § 325E.042

## REGULATION OF TRADE PRACTICES

### 1988 Legislation

Laws 1988, c. 685, § 46, provides that subd. 2, added along with the rest of the section by Laws 1988, c. 685, § 26, is effective July 1, 1989.

### §25E.044. Plastic container labeling

**Subdivision 1. Definitions.** The definitions in this subdivision apply to this section.

(a) "Distributor" means a person engaged in business that ships or transports products to retailers in this state to be sold by those retailers.

(b) "Labeling" means attaching information to or embossing or printing information on a plastic container.

(c) "Manufacturer" means any manufacturer offering for sale and distribution a product packaged in a container.

(d) "Plastic container" means an individual, separate, plastic bottle, can, or jar with a capacity of sixteen ounces or more.

**Subd. 2. Labeling rules required.** By March 31, 1989, the board shall adopt rules requiring labeling of plastic containers. The rules adopted under this subdivision must allow a manufacturer of plastic containers, a person who places products in plastic containers, and a person who sells products in plastic containers to choose an appropriate method of labeling plastic containers. The board shall adopt rules as consistent as practicable with national industrywide plastic container coding systems. The rules may exempt plastic containers of a capacity of less than a specified minimum size from the labeling requirements.

**Subd. 3. Prohibition.** A person may not manufacture or bring into the state for sale in this state a plastic container that does not comply with the labeling rules adopted under subdivision 2.

**Subd. 4. Enforcement; civil penalty; injunctive relief.** (a) After being notified that a plastic container does not comply with the rules under subdivision 2, any manufacturer or distributor who violates subdivision 3 is subject to a civil penalty of \$50 for each violation up to a maximum of \$500 and may be enjoined from such violations.

(b) The attorney general may bring an action in the name of the state in a court of competent jurisdiction for recovery of civil penalties or for injunctive relief as provided in this subdivision. The attorney general may accept an assurance of discontinuance of acts in violation of subdivision 3 in the manner provided in section 8.31, subdivision 2b.

Laws 1988, c. 685, § 27.

## DEGRADABLE PLASTICS [NEW]

### 325E.045. Purchase, sale, and use of certain polyethylene material prohibited

**Subdivision 1. Definitions.** The definitions in this subdivision apply to this section.

(a) "Degradable" means capable of being decomposed by natural biological processes, including exposure to ultraviolet rays of the sun, within five years after the date of disposal.

(b) "Person" means an individual, partnership, corporation, sole proprietorship, association, or other for-profit or nonprofit organization, including the state and its political subdivisions.

(c) "Polyethylene disposal bag" means a bag made of polyethylene that is used or intended to be used for disposal of mixed municipal solid waste as defined in section 115A.03.

(d) "Polyethylene beverage ring" means a device made of polyethylene that is used or intended to be used to hold beverage bottles or other beverage containers together.

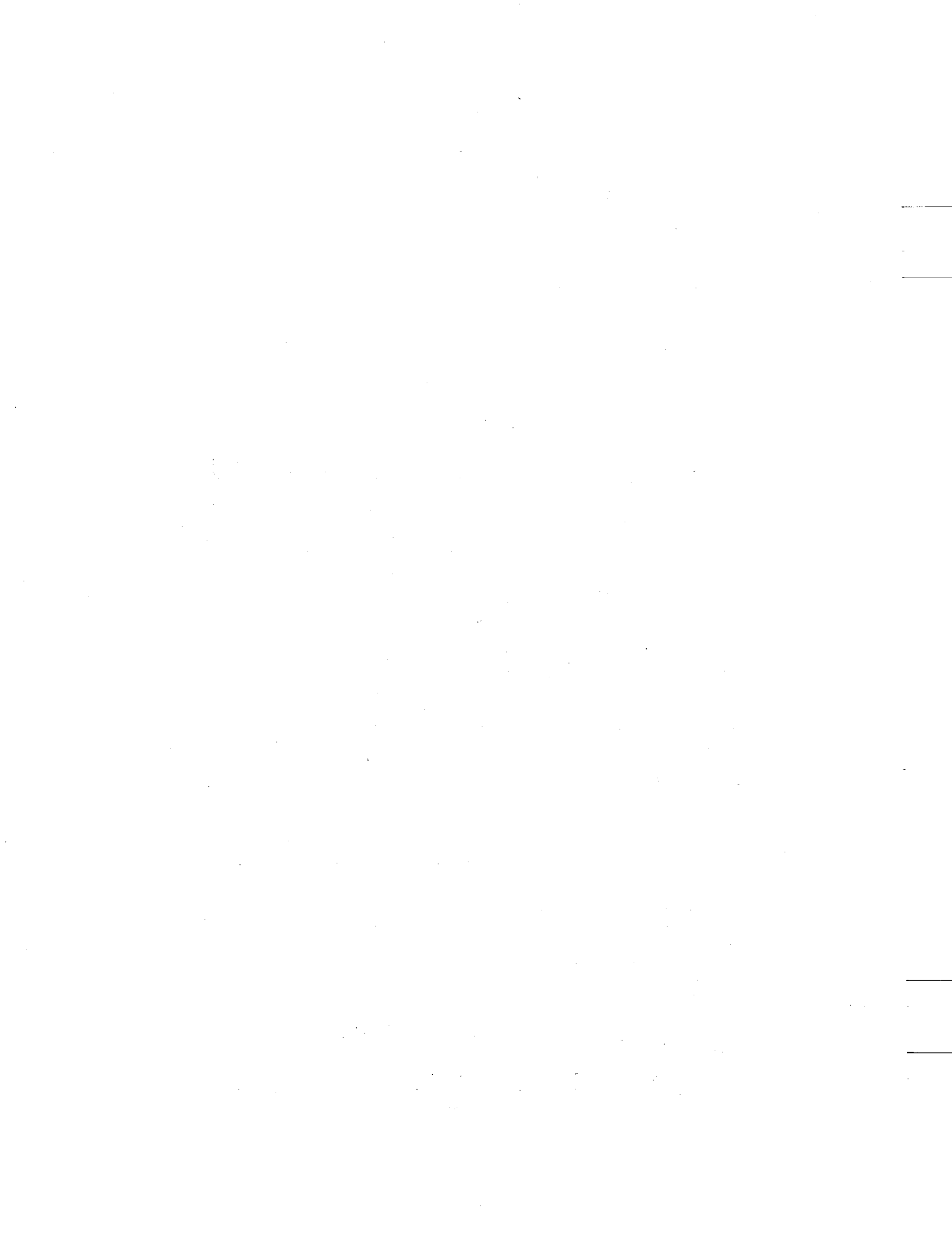

## MISSOURI

1. **Compliance Date:** January 1, 1992
2. **Scope:** Plastic bottles and plastic containers that can be shaped by flow distributed, sold, or offered for sale in the state by retail or wholesale businesses unless exempted by regulation.\*/

<u>Type</u>	<u>Size</u>
<u>Plastic Bottles</u> -- Container with neck smaller than its body and accepts a closure.	16 ounces to 5 gallons †
<u>Rigid Plastic Containers</u> -- Other than bottle; intended for single use; relatively inflexible finite shape.	8 ounces to 5 gallons †

3. **Required Codes:**

<u>Resin Type</u>	<u>Code Number</u> †	<u>Code Letters</u> †
Polyethylene Terephthalate	1	PETE
High Density Polyethylene	2	HDPE
Vinyl	3	V
Low Density Polyethylene	4	LDPE
Polypropylene	5	PP
Polystyrene	6	PS
Other	7	OTHER

---

\*/ Exemptions to include: (1) readily identifiable plastic containers; (2) plastic containers for which there is no technological capability for recycling; (3) plastic containers for which recycling, reclamation or reuse is not economically feasible; (4) plastic containers with a capacity less than a minimum size as determined by the Department of Agriculture.

† Denotes requirements that are consistent with the SPI Voluntary Code

PLASTIC CONTAINER CODING SUMMARY

- A. Base cups and labels: Plastic containers and bottles with base cups of a different material shall be coded by their basic material. †
- B. Multilayer: Include as "7-OTHER."
4. **Required Symbol**: RIS; size not specified. †
5. **Type and Location of Code**: Molded imprint or raised symbol on or near the bottom of the bottle or container.
6. **Penalties**: Violators are guilty of a Class A misdemeanor. Each day of violation constitutes a separate offense.
7. **Additional Information**:
- Department of Natural Resources  
1014 Madison Street  
Jefferson City, Missouri 65101  
Steven Jeffreys: (314) 751-4732  
Kathy Weinsaft: (314) 751-7971
8. **Attachment**: RS Mo 260.281 (House Bills 438, 440, 96, 97 Section 4.1 attached)

† Denotes requirements that are consistent with the SPI Voluntary Code

[TRULY AGREED TO AND FINALLY PASSED]

HOUSE COMMITTEE SUBSTITUTE FOR

**HOUSE BILLS NOS.****438, 440, 96 & 97****85TH GENERAL ASSEMBLY**

Section 4. 1. As used in this section, the following

2 terms mean:

3 (1) "Label", a molded imprint or raised symbol on  
4 or near the bottom of a plastic product;

5 (2) "Person", an individual, sole proprietor, partner-  
6 ship, association, corporation or other legal entity;

7 (3) "Plastic", any material made of polymeric  
8 organic compounds and additives that can be shaped  
9 by flow;

10 (4) "Plastic bottle", a plastic container that has a  
11 neck that is smaller than the body of the container,  
12 accepts a screwtype, snap cap or other closure and has  
13 a capacity of sixteen fluid ounces or more, but less than  
14 five gallons;

15 (5) "Rigid plastic container", any formed or molded  
16 container, other than a bottle, intended for single use,  
17 composed predominantly of plastic resin, and having a  
18 relatively inflexible finite shape or form with a capacity  
19 of eight ounces or more but less than five gallons.

20 2. Beginning January 1, 1992, no retail or wholesale  
21 business shall distribute, sell or offer for sale in this state  
22 any plastic bottle or rigid plastic container or any product  
23 in such a bottle or container unless the product bottle  
24 or container is labeled with a code indicating the plastic  
25 resin used to produce the bottle or container. Rigid plastic  
26 bottles or rigid plastic containers with labels and  
27 basecups of a different material shall be coded by their  
28 basic material. The code shall consist of a number placed  
29 within a triangle of arrows and letters placed below the  
30 triangle of arrows. The triangle shall be equilateral,  
31 formed by three arrows with the apex of each point of  
32 the triangle at the midpoint of each arrow, rounded with  
33 a short radius. The arrowhead of each arrow shall be  
34 at the midpoint of each side of the triangle with a short  
35 gap separating the pointer from the base of the adjacent  
36 arrow. The triangle, formed by the three arrows curved  
37 at their midpoints shall depict a clockwise path around  
38 the code number. The numbers and letters used shall be  
39 as follows:

- 40 (1) "1" - PETE (polyethylene terephthalate);
- 41 (2) "2" - HDPE (high density polyethylene);
- 42 (3) "3" - V (vinyl);
- 43 (4) "4" - LDPE (low density polyethylene);
- 44 (5) "5" - PP (polypropylene);
- 45 (6) "6" - PS (polystyrene);
- 46 (7) "7" - OTHER (includes multi-layer).

47 3. The department of natural resources shall deter-  
48 mine through rules and regulations which plastic  
49 containers may be exempt from the labeling requirements  
50 including but not limited to:

- 51 (1) Readily identifiable plastic containers;
- 52 (2) Plastic containers for which there is no techno-  
53 logical capability for recycling, reclamation or reuse;
- 54 (3) Plastic containers for which recycling, reclama-  
55 tion or reuse is not economically feasible; and
- 56 (4) Plastic containers of a capacity less than a  
57 specified minimum size as determined by the department  
58 of agriculture.

59 4. Any person who violates subsection 2 of this  
60 section shall be guilty of a class A misdemeanor. Each  
61 day of violation constitutes a separate offense.

## NORTH DAKOTA

1. **Compliance Date:** December 31, 1991
2. **Scope:** Plastic products that can be shaped by flow sold in the state:

<u>Type</u>	<u>Size</u>
<u>Plastic Bottles</u> -- Container with neck smaller than its body and accepts a closure.	16 ounces to 5 gallons †
<u>Rigid Plastic Containers</u> -- Other than bottle; intended for single use; relatively inflexible finite shape	8 ounces to 5 gallons †

3. **Required Codes:**

<u>Resin Type</u>	<u>Code Number</u>	<u>Code Letters</u>
Polyethylene Terephthalate	1 †	PETE †
High Density Polyethylene	2 †	HDPE †
Vinyl	3 †	V †
Low Density Polyethylene	4 †	LDPE †
Polypropylene	5 †	PP †
Polystyrene	6 †	PS †
Multilayer	7	OTHER
Degradable	8	D

- A. Base cups and labels: Not Applicable.
- B. Multilayer: Defined as "7-OTHER."
- C. Degradable: Capable of being reduced to environmentally benign subunits under the action of normal environmental forces, including biodegradation, photodegradation, chemical degradation or hydrolysis within reasonable times specific for waste types and waste management methods.

† Denotes requirements that are consistent with the SPI Voluntary Code

PLASTIC CONTAINER CODING SUMMARY

4. **Required Symbol:** RIS; Size - Numbers and letters of at least 1/2 inch (12.7 millimeters).
5. **Type and Location of Code:** Molded imprint or raised symbol on or near the bottom of the bottle or container.
6. **Penalties:** Violators are guilty of an infraction. No specific penalties are provided.
7. **Additional Information:**

Mr. Martin Schock  
Director, Division of Waste Management  
North Dakota Department of Health  
Post Office Box 5520  
Bismarck, North Dakota 58502  
(701) 224-2366

8. **Attachment:** N.D. CENT. CODE §§23-32-01 to 23-32-04  
(1989), April 10, 1989



23-32-01

HEALTH AND SAFETY

CHAPTER 23-32

PLASTIC PRODUCTS DEGRADATION AND LABELING

Section

23-32-01. Definitions.

23-32-02. Degradation rates — Byproducts of degradation.

23-32-03. Plastic bottles and containers — Label — Penalty.

Section

23-32-04. Degradable plastic rings — Penalty.

**23-32-01. Definitions.** As used in sections 23-32-01 through 23-32-04:

1. "Degradable" means capable of being reduced to environmentally benign subunits under the action of normal environmental forces, including biodegradation, photodegradation, chemical degradation, or hydrolysis within reasonable time lines specific for waste types and waste management methods.
2. "Department" means the state department of health and consolidated laboratories.
3. "Label" means a molded imprint or raised symbol.
4. "Plastic" means any material made of polymeric organic compounds and additives that can be shaped by flow.
5. "Plastic bottle" means a plastic container that has a neck that is smaller than the body of the container, accepts a screw-type, snap cap, or other closure, and has a capacity of at least sixteen fluid ounces [453.60 grams] but less than five gallons [18.93 liters].
6. "Rigid plastic container" means any formed or molded container, other than a bottle, intended for single use, composed predominately of plastic resin, and having a relatively inflexible finite shape or form with a capacity of at least eight ounces [226.80 grams] but not more than five gallons [18.93 liters].

**Source:** S.L. 1989, ch. 329, § 1.

effective July 10, 1989, 90 days after filing, pursuant to N.D. Const., Art. IV, § 13.

**Effective Date.**

The act which added this chapter became

**23-32-02. Degradation rates — Byproducts of degradation.** The department, in cooperation with the American society for testing and materials, the United States environmental protection agency, and the national institute of standards and technology, shall adopt rules regarding the required rates of degradation and allowable byproducts of degradation. The department may require test data to demonstrate that a plastic is degradable including the rate of degradation and the byproducts of the degradation.

Source: S.L. 1989, ch. 329, § 2.

**23-32-03. Plastic bottles and containers — Label — Penalty.**

1. All plastic bottles and rigid plastic containers sold in this state after December 31, 1991, must have a label indicating the plastic resin used to produce the bottle or container. The numbers and letters used on the label must be at least one-half inch [12.7 millimeters] high and must appear on the bottom of the plastic bottle or rigid plastic container. The label must consist of the following numbers, placed inside three triangulated arrows, and letters placed immediately below the three triangulated arrows depending on the plastic resin used. The triangulated arrows must be equilateral, formed by three arrows with the apex of each point of the triangle at the midpoint of each arrow, rounded with a short radius. The pointer (arrowhead) of each arrow must be at the midpoint of each side of the triangle with a short gap separating the pointer from the base of the adjacent arrow. The triangle formed by the three arrows curved at their midpoints must depict a clockwise path around the code number. The numbers and letters used must be as follows:
  - a. 1 PETE if the product used is polyethylene terephthalate.
  - b. 2 HDPE if the product used is high density polyethylene.
  - c. 3 V if the product used is vinyl.
  - d. 4 LDPE if the product used is low density polyethylene.
  - e. 5 PP if the product used is polypropylene.
  - f. 6 PS if the product used is polystyrene.
  - g. 7 OTHER if the product used is multilayer.
  - h. 8 D if the product used is degradable.
2. The department shall maintain a list of the label code contained in this section and shall provide a copy of the list to any person upon request.
3. Any person who violates this section is guilty of an infraction.

Source: S.L. 1989, ch. 329, § 3.

## OHIO

1. **Compliance Date:** January 1, 1991
2. **Scope:** Plastic products that can be shaped by flow manufactured or distributed for use in the state:

<u>Type</u>	<u>Size</u>
<u>Plastic Bottles</u> -- Container with neck smaller than its body and accepts a closure.	16 ounces to 5 gallons †
<u>Rigid Plastic Containers</u> -- Other than bottle; intended for single use; relatively inflexible finite shape.	8 ounces to 5 gallons †

3. **Required Codes:\*/**

<u>Resin Type</u>	<u>Code Number</u> †	<u>Code Letters</u> †
Polyethylene Terephthalate	1	PETE
High Density Polyethylene	2	HDPE
Vinyl	3	V
Low Density Polyethylene	4	LDPE
Polypropylene	5	PP
Polystyrene	6	PS
Other	7	OTHER

- A. Base cups and labels: A plastic bottle or rigid plastic container having a base cup or label composed of different material from that comprising the rest of the bottle or container should be coded as the basic material used in the bottle or container. †
- B. Multilayer: Include as "7-OTHER."

---

\*/ New codes may be adopted by the Director of Environmental Protection when appropriate. New codes shall be consistent with the code number and code letter similar to those established pursuant to the laws of other states.

† Denotes requirements that are consistent with the SPI Voluntary Code

4. **Required Symbol:** RIS; Size not specified. †
5. **Type and Location of Code:** Molded imprint or raised symbol on or near the bottom of the bottle or container.
6. **Penalties:** Statute provides for an action for injunction against a person who has violated, is violating, or is threatening to violate the coding requirements.
7. **Additional Information:**

Ms. Mary Wiard  
Chief, Division of Litter  
Prevention and Recycling  
Ohio Department of Natural  
Resources  
Fountain Square E1  
Columbus, Ohio 43224  
(614) 265-6353

8. **Attachment:** OHIO REV. CODE §3734.60

† Denotes requirements that are consistent with the SPI Voluntary Code

As Passed by the House	1.4
118th General Assembly	1.6
Regular Session	Am. S. B. No. 142 1.7
1989-1990	SAH 1.8
MESSRS. RAY-CUPP-BURCH-BRANSTOOL-FISHER-WHITE-BOEHNER-	1.10
STOZICH-SCHUCK-MRS. BERGANSKY-MESSRS. ROBERTS-	1.11
SECRET-HAINES-T. JOHNSON-MS. LUCAS	1.12
	1.13
<hr/>	
A B I L L	1.14
To amend sections 3734.04, 3734.10, 3734.13, and	1.16
3734.99 and to enact section 3734.60 of the	1.17
Revised Code to require labeling on and after	1.18
January 1, 1991 of certain plastic bottles and	1.19
containers with a code indicating the plastic	1.20
resin used to produce them.	1.21
BE IT ENACTED BY THE GENERAL ASSEMBLY OF THE STATE OF OHIO:	1.24
Section 1. That sections 3734.04, 3734.10, 3734.13, and	1.26
3734.99 be amended and section 3734.60 of the Revised Code be	1.27
enacted to read as follows:	1.28
Sec. 3734.04. The board of health of each district	1.30
maintaining a program on the approved list under division (A) or	1.31
(B) of section 3734.08 of the Revised Code shall provide for the	1.32
inspection, licensing, and enforcement of sanitary standards for	1.33
solid waste facilities in conformity with this chapter. The	1.34
director of environmental protection shall provide for the	1.35
inspection of hazardous waste facilities and of generators and	1.36
transporters of hazardous waste, issuance of permits, and	2.1
enforcement of this chapter and of rules adopted thereunder	2.2
governing THE storage, treatment, transportation, and disposal of	2.4
hazardous waste, AND ALSO SHALL PROVIDE FOR THE ENFORCEMENT OF	2.5
SECTION 3734.60 OF THE REVISED CODE.	
Sec. 3734.10. The attorney general or the prosecuting	2.8
attorney of the county or the city director of law where a	2.10
violation has occurred, is occurring, or may occur, upon request	2.11
of the respective board of health of the health district, the	2.12

legislative authority of a political subdivision in which a 2.14  
violation has occurred, is occurring, or may occur, or the 2.15  
director of environmental protection, shall prosecute to 2.17  
termination or bring an action for injunction against any person 2.18  
who has violated, is violating, or is threatening to violate any 2.20  
section of this chapter, rules adopted under this chapter, or 2.21  
terms or conditions of permits, licenses, variances, or orders 2.22  
issued under this chapter. IN THE INSTANCE OF A VIOLATION OF 2.23  
SECTION 3734.60 OF THE REVISED CODE, ONLY THE DIRECTOR OF 2.24  
ENVIRONMENTAL PROTECTION MAY REQUEST THE ATTORNEY GENERAL, OR THE 2.25  
PROSECUTING ATTORNEY OF THE COUNTY OR CITY DIRECTOR OF LAW WHERE 2.26  
A VIOLATION OF THAT SECTION HAS OCCURRED, IS OCCURRING, OR MAY 2.27  
OCCUR, TO BRING AN ACTION FOR INJUNCTION AGAINST A PERSON WHO HAS 2.28  
VIOLATED, IS VIOLATING, OR IS THREATENING TO VIOLATE THAT 2.29  
SECTION. The court of common pleas in which an action for 2.31  
injunction is filed has the jurisdiction to and shall grant 2.32  
preliminary and permanent injunctive relief upon a showing that 2.35  
the person against whom the action is brought has violated, is 2.36  
violating, or is threatening to violate any section of this 3.2  
chapter, rules adopted thereunder, or terms or conditions of 3.3  
permits, licenses, variances, or orders issued under this 3.4  
chapter. The court shall give precedence to such an action over 3.6  
all other cases.

Upon written request by any person, the board of health or 3.9  
the director shall conduct such investigations and make such 3.10  
inquiries as are necessary to secure compliance with this chapter 3.11  
or the rules adopted thereunder. The director or any board of 3.12  
health may, upon request or upon their own initiative, 3.13  
investigate or make inquiries into any alleged violation or act 3.15  
of improper solid waste disposal, improper infectious waste 3.16  
transportation or treatment, or improper hazardous waste storage, 3.17  
transportation, treatment, or disposal. 3.18

This chapter does not abridge rights of action or remedies 3.21  
in equity, under common law, or as provided by statute or prevent 3.22  
the state or any municipal corporation or person in the exercise 3.23

of their rights in equity, under common law, or as provided by 3.24  
statute to suppress nuisances or to abate or prevent pollution. 3.26

Sec. 3734.13. (A) The director of environmental 3.28  
protection may issue, modify, suspend, or revoke enforcement 3.29  
orders in accordance with Chapter 3745. of the Revised Code to a 3.31  
permit or license holder or other person, directing the holder or 3.32  
person to abate violation, or to prevent any threatened 3.33  
violation, of any section of this chapter, a rule adopted 3.34  
thereunder, or a term or condition of a permit, license, or 3.35  
variance issued thereunder within a specified, reasonable time. 4.2

(B) If the director determines that an emergency exists 4.3  
requiring immediate action to protect the public health or safety 4.5  
or the environment, he may, without notice or hearing, issue an 4.6  
order reciting the existence of the emergency and requiring that 4.7  
such action be taken as necessary to meet the emergency. The 4.9  
order shall be effective immediately. Any person to whom the 4.10  
order is directed shall comply immediately, but on application to 4.11  
the director shall be afforded a hearing as soon as possible, and 4.12  
not later than thirty days after application. On the basis of 4.13  
the hearing, the director shall continue the order in effect, 4.14  
revoke it, or modify it. No emergency order shall remain in 4.15  
effect for more than one hundred twenty days after its issuance. 4.16

(C) If the director determines that any person is 4.17  
violating or has violated this chapter, a rule adopted 4.18  
thereunder, or a term or condition of a permit, license, 4.20  
variance, or order issued thereunder, the director may request in 4.21  
writing that the attorney general bring a civil action for 4.23  
appropriate relief, including a temporary restraining order, 4.24  
preliminary or permanent injunction, and civil penalties in any 4.26  
court of competent jurisdiction. Such an action shall have 4.27  
precedence over all other cases. The court may impose upon the 4.28  
person a civil penalty of not more than ten thousand dollars for 4.29  
each day of each violation of this chapter OTHER THAN A VIOLATION 4.31  
OF SECTION 3734.60 OF THE REVISED CODE, a rule adopted thereunder 4.33  
other than a rule adopted under division (B) of section 3734.122 4.34

of the Revised Code, or a term or condition of a permit, license, 4.35  
variance, or order issued thereunder. The court may impose upon 4.36  
a person who violates a rule adopted under division (B) of 5.1  
section 3734.122 of the Revised Code a civil penalty of not more 5.2  
than twenty-five thousand dollars for each day of each violation 5.3  
of the rule. THE COURT MAY IMPOSE UPON A PERSON WHO VIOLATES 5.4  
SECTION 3734.60 OF THE REVISED CODE A CIVIL PENALTY OF NOT MORE 5.5  
THAN TWO HUNDRED FIFTY DOLLARS FOR EACH DAY OF VIOLATION OF THAT 5.6  
SECTION. 5.7

Any action under this section is a civil action, governed 5.9  
by the Rules of Civil Procedure. 5.10

(D) No person shall violate any term or condition of any 5.12  
order issued under this section. 5.13

(E) Moneys resulting from civil penalties imposed under 5.16  
division (C) of this section shall be paid into the hazardous 5.17  
waste clean-up fund created in section 3734.28 of the Revised 5.18  
Code.

Sec. 3734.60. (A) AS USED IN THIS SECTION: 5.21

(1) "LABEL" MEANS A MOLDED IMPRINT OR RAISED SYMBOL THAT 5.23  
INCLUDES A CODE CONSISTING OF LETTERS AND NUMBERS AND IS PLACED 5.24  
ON OR NEAR THE BOTTOM OF A PLASTIC BOTTLE OR RIGID PLASTIC 5.25  
CONTAINER TO INDICATE THE PLASTIC RESIN USED TO PRODUCE THE 5.26  
BOTTLE OR CONTAINER. 5.27

(2) "PLASTIC" MEANS ANY MATERIAL MADE OF POLYMERIC ORGANIC 5.29  
COMPOUNDS AND ADDITIVES THAT CAN BE SHAPED BY MEANS OF THE 5.30  
FLOWING OF THE MATERIAL. 5.31

(3) "PLASTIC BOTTLE" MEANS A PLASTIC CONTAINER THAT HAS A 5.33  
NECK THAT IS SMALLER THAN THE BODY OF THE CONTAINER; THAT ACCEPTS 5.35  
A SCREW-TYPE CAP, SNAP CAP, OR OTHER CLOSURE; AND THAT HAS A 5.36  
CAPACITY OF AT LEAST SIXTEEN OUNCES BUT LESS THAN FIVE GALLONS. 6.1

(4) "RIGID PLASTIC CONTAINER" MEANS ANY FORMED OR MOLDED 6.3  
CONTAINER, OTHER THAN A PLASTIC BOTTLE, THAT IS INTENDED FOR A 6.4  
SINGLE USE, IS COMPOSED PRIMARILY OF PLASTIC RESIN, HAS A 6.5  
RELATIVELY INFLEXIBLE FINITE SHAPE OR FORM, AND HAS A CAPACITY OF 6.7  
AT LEAST EIGHT OUNCES BUT LESS THAN FIVE GALLONS.



(B) ON AND AFTER JANUARY 1, 1991, NO PERSON SHALL EITHER 6.10  
 MANUFACTURE OR DISTRIBUTE FOR USE IN THIS STATE ANY NEW, UNFILLED 6.11  
 PLASTIC BOTTLE OR RIGID PLASTIC CONTAINER UNLESS IT BEARS A LABEL 6.12  
 WITH THE APPROPRIATE CODE AS PRESCRIBED IN THIS SECTION THAT 6.13  
 INDICATES THE PLASTIC RESIN USED TO PRODUCE THE BOTTLE OR 6.14  
 CONTAINER. A PLASTIC BOTTLE OR RIGID PLASTIC CONTAINER HAVING A 6.15  
 LABEL OR BASECUP COMPOSED OF MATERIAL DIFFERENT FROM THAT 6.16  
 COMPRISING THE REST OF THE BOTTLE OR CONTAINER SHALL BE LABELED 6.17  
 WITH THE CODE FOR THE BASIC MATERIAL USED IN THE BOTTLE OR 6.18  
 CONTAINER.

THE LABEL REQUIRED BY THIS SECTION SHALL CONSIST OF AN 6.20  
 EQUILATERAL TRIANGLE FORMED BY THREE CURVED ARROWS OF SHORT 6.21  
 RADIUS WITH THE APEX OF EACH POINT OF THE TRIANGLE AT THE 6.22  
 MIDPOINT OF EACH ARROW. THE HEAD OF EACH ARROW SHALL BE AT THE 6.23  
 MIDPOINT OF EACH SIDE OF THE TRIANGLE WITH A SHORT GAP BETWEEN 6.24  
 THE HEAD OF THE ARROW AND THE BASE OF THE SUCCEEDING ARROW. THE 6.25  
 TRIANGLE FORMED BY THE THREE CURVED ARROWS SHALL DEPICT A 6.26  
 CLOCKWISE PATH AROUND THE CODE NUMBER, WHICH SHALL BE PLACED AT 6.27  
 THE CENTER OF THE TRIANGLE. THE CODE LETTERS SHALL BE PLACED 6.28  
 IMMEDIATELY BELOW THE TRIANGLE. THE FOLLOWING CODE NUMBERS AND 6.29  
 LETTERS SHALL BE USED ON THE LABELS: 6.30

(1) FOR POLYETHYLENE TEREPHTHALATE, THE LETTERS "PETE" AND 6.33  
 THE NUMBER "1";

(2) FOR HIGH DENSITY POLYETHYLENE, THE LETTERS "HDPE" AND 6.36  
 THE NUMBER "2";

(3) FOR VINYL, THE LETTER "V" AND THE NUMBER "3"; 7.2

(4) FOR LOW DENSITY POLYETHYLENE, THE LETTERS "LDPE" AND 7.5  
 THE NUMBER "4";

(5) FOR POLYPROPYLENE, THE LETTERS "PP" AND THE NUMBER 7.7  
 "5"; 7.8

(6) FOR POLYSTYRENE, THE LETTERS "PS" AND THE NUMBER "6"; 7.11

(7) FOR ANY PLASTIC MATERIAL NAMED IN RULES ADOPTED UNDER 7.13  
 DIVISION (C) OF THIS SECTION, THE CODE LETTER AND CODE NUMBER 7.14  
 PRESCRIBED FOR THE PLASTIC MATERIAL IN THOSE RULES; 7.15

(8) FOR ANY OTHER PLASTIC, INCLUDING, WITHOUT LIMITATION, 7.17  
MULTILAYER MATERIALS, THE WORD "OTHER" AND THE NUMBER "7". 7.19

(C) WHEN THE DIRECTOR OF ENVIRONMENTAL PROTECTION 7.21  
CONSIDERS IT APPROPRIATE, HE MAY ADOPT RULES IN ACCORDANCE WITH 7.22  
CHAPTER 119. OF THE REVISED CODE LISTING PLASTIC MATERIALS IN 7.24  
ADDITION TO THOSE LISTED IN DIVISIONS (E)(1) TO (6) OF THIS  
SECTION AND PRESCRIBING A CODE LETTER AND CODE NUMBER FOR EACH OF 7.26  
THOSE ADDITIONAL PLASTIC MATERIALS. WHEN LABELING REQUIREMENTS 7.27  
SIMILAR TO THOSE ESTABLISHED BY THIS SECTION HAVE BEEN 7.28  
ESTABLISHED PURSUANT TO THE LAWS OF OTHER STATES FOR ANY SUCH 7.29  
ADDITIONAL MATERIAL, THE CODE NUMBER AND CODE LETTER FOR THAT 7.30  
MATERIAL ESTABLISHED UNDER THIS DIVISION SHALL BE CONSISTENT WITH 7.31  
THE CODE NUMBER AND CODE LETTER FOR THAT MATERIAL ESTABLISHED 7.32  
PURSUANT TO THE LAWS OF THOSE OTHER STATES.

(2) THE ENVIRONMENTAL PROTECTION AGENCY SHALL MAINTAIN A 7.34  
LIST OF THE CODES PRESCRIBED IN DIVISIONS (E)(1) TO (8) OF THIS 7.36  
SECTION AND SHALL PROVIDE A COPY OF THE LIST TO ANY PERSON UPON 8.1  
REQUEST.

Sec. 3734.99. (A) Except as otherwise provided in 8.3  
divisions (B), (C), and (D) of this section, whoever recklessly 8.4  
violates any section of this chapter, except section 3734.18 or 8.7  
3734.57, OR 3734.60 of the Revised Code is guilty of a felony and 8.9  
shall be fined at least ten thousand dollars, but not more than 8.10  
twenty-five thousand dollars, or imprisoned for at least two 8.11  
years, but not more than four years, or both. Whoever violates 8.12  
section 3734.18 or 3734.57 of the Revised Code shall be fined not 8.13  
more than ten thousand dollars. Each day of violation 8.15  
constitutes a separate offense.

(B) Whoever violates division (G) of section 3734.05 of 8.17  
the Revised Code with respect to a report required pursuant to a 8.18  
plan approved under division (A) of section 3734.041 of the 8.19  
Revised Code or violates division (D) of section 3734.13 of the 8.20  
Revised Code with respect to an order issued pursuant to division 8.22  
(C) or (D) or section 3734.041 of the Revised Code is guilty of a 8.23  
felony and shall be fined at least ten thousand dollars, but not 8.24

more than twenty-five thousand dollars, or imprisoned for at least two years, but not more than four years, or both. Each day of violation constitutes a separate offense.

(C) Upon the second or subsequent conviction for a violation of any section of this chapter, except section 3734.18 or 3734.57, OR 3734.60 or a rule adopted under division (B) of section 3734.122 of the Revised Code, the offender shall be fined at least twenty thousand dollars, but not more than fifty thousand dollars per day of violation, or imprisoned for at least two years, but not more than four years, or both.

(D) Whoever knowingly violates a rule adopted under division (B) of section 3734.122 of the Revised Code shall be fined not more than twenty-five thousand dollars for each day of violation, or imprisoned for not more than one year, or both.

Section 2. That existing sections 3734.04, 3734.10, 3734.13, and 3734.99 of the Revised Code are hereby repealed.

\_\_\_\_\_

\_\_\_\_\_

## WISCONSIN

1. **Compliance Date:** As noted under **Scope**.
2. **Scope:** Plastic containers (not limited to thermoplastics) or a product in such a container, manufactured or offered for sale at wholesale in the state per the schedule set forth below unless exempted by rule.\*/ Also applicable to retail sales of containers, effective 1 year after the corresponding manufacturer/ wholesaler requirement becomes effective.

Type

Size

Plastic Beverage Bottle --  
Any plastic bottle that contains a beverage.

8 ounces or more, effective  
January 1, 1991

Plastic Bottles -- Other  
containers whose effective  
neck is smaller than its  
body, with screw-on or  
press-on lid.

16 ounces or greater, effective  
January 1, 1991; 8 ounces or  
greater, effective January 1,  
1993.

Containers -- Other than  
plastic bottles.

16 ounces or greater, effective  
January 1, 1991; 8 ounces or  
greater, effective January 1,  
1992.

---

\*/ The rules shall exempt from the labeling requirements plastic containers that are readily identifiable because of their appearance and plastic containers for which there is no technological capability for recycling, reclamation or reuse or for which recycling, reclamation or reuse is not economically feasible.

† Denotes requirements that are consistent with the SPI Voluntary Code

**3. Required Codes:**

<u>Resin Type</u>	<u>Code Number †</u>	<u>Code Letters †</u>
Polyethylene Terephthalate	1	PETE
High Density Polyethylene	2	HDPE
Vinyl	3	V
Low Density Polyethylene	4	LDPE
Polypropylene	5	PP
Polystyrene	6	PS
Other	7	OTHER

- A. Base cups and labels: May be labeled according to the container's principal resin.
  - B. Multilayer: Include as "7-OTHER."
4. **Required Symbol:** RIS; must be 1/2" high if possible.
  5. **Type and Location of Code:** Affixed, embossed or printed symbol; Size not specified.
  6. **Penalties:** Not more than \$500 for each violation. Each day of violation is a separate offense.
  7. **Additional Information:**

Department of Agriculture  
 Trade and Consumer Protection  
 801 West Badger Road  
 Madison, Wisconsin 53708  
 (608) 266-7100

8. **Attachments:** WIS. STAT. ANN § 100.33 (West 1989),  
 April 26, 1988  
 June 10, 1989 Amendment  
  
 Wisconsin Administrative Code  
 §§ 57.01 et seq.



# State of Wisconsin

Department of Agriculture, Trade & Consumer Protection

Alan T. Tracy  
Secretary

801 West Badger Road  
PO Box 5911  
Madison, WI 53708-5911

DATE: October 10, 1990

TO: Gary Poulson, Revisor of Statutes Office  
Room 702, 30 West Mifflin Street

FROM: Donald J. Soberg, Administrator *DJS*  
Trade and Consumer Protection Division

RE: Clearinghouse Rule #88-199  
Chapter Ag 57, Labeling Plastic Containers for  
Recycling, Reclamation and Reuse

## Summary of Final Regulatory Flexibility Analysis

This rule has been reviewed pursuant to s. 227.114, Stats., and it has been determined that the rule will not have a significant economic impact on a substantial number of small businesses, beyond that imposed by the statute itself. The phased-in effective dates for the plastic container labeling requirements, enacted as part of 1989 Wis. Act 31, should assure ample time for container manufacturers to comply with coding requirements and minimize any conceivable economic impacts on retailers and wholesalers. Accordingly, the rule requires no special consideration for small businesses.

## Comments from Legislative Committees

This rule was originally submitted to the Assembly Natural Resources Committee and the Senate Urban Affairs, Environmental Resources, Utilities and Election Committee in October 1989. The Chair of the Senate Committee asked that the Department withdraw the rules because the legislature was considering further amendments to s. 100.33, Stats. The Department agreed to the request. After enactment of amendments to s. 100.33 in 1989 Wis. Act 335, the Board of Agriculture, Trade and Consumer Protection approved appropriate changes to this rule and it was resubmitted to the same two committees in July 1990. Neither committee recorded any objections to the rule upon its return.

DJS/p/12/T3

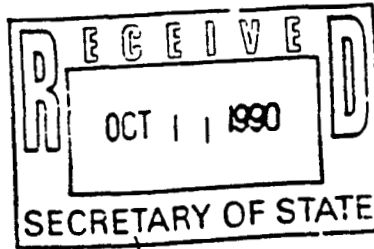

RECEIVED

OCT 11 1990

Revisor of Statutes  
Bureau

STATE OF WISCONSIN

DEPARTMENT OF AGRICULTURE,  
TRADE AND CONSUMER PROTECTION )

) ss.

I, Donald J. Soberg, Administrator of the Division of Trade and Consumer Protection, Wisconsin Department of Agriculture, Trade and Consumer Protection, and custodian of the official records, certify that the annexed rules, relating to labeling plastic containers for recycling, reclamation and reuse, were duly approved and adopted by this department on October 10, 1990.

I further certify that this copy has been compared by me with the original on file in this department and that it is a true copy of the original, and of the whole of the original.

IN TESTIMONY WHEREOF, I have hereunto set my hand and affixed the official seal of the Department of Agriculture, Trade and Consumer Protection at 801 West Badger Road in the city of Madison, this 10th day of October 1990.

Donald J. Soberg, Administrator  
Division of Trade and Consumer  
Protection, Wisconsin Department of  
Agriculture, Trade and Consumer  
Protection





ORDER OF  
THE STATE OF WISCONSIN DEPARTMENT OF  
AGRICULTURE, TRADE AND CONSUMER PROTECTION

The Wisconsin department of agriculture, trade and consumer protection hereby adopts the following order to create Ag 57, relating to labeling plastic containers for recycling, reclamation and reuse.

-----  
Analysis Prepared by the Department of Agriculture,  
Trade and Consumer Protection

Statutory authority: s. 100.33 (2), Stats.  
Statute interpreted: s. 100.33, Stats.

1987 Wisconsin Act 293 created s. 100.33, Stats., a statute requiring that plastic containers be labeled to promote their recycling, reclamation and reuse. This law prohibits selling plastic containers, or products in plastic containers, unless the containers are labeled with information needed by recyclers.

Section 100.33, Stats., has a staggered effective date, depending on the size and type of the container and whether it is sold at wholesale or retail:

<u>Type and Size of Container</u>	<u>Effective Date Wholesale Sales</u>	<u>Effective Date Retail Sales</u>
16 oz. and larger containers in general	01/01/91	01/01/92
16 oz. and larger non-beverage bottles	"	"
8 oz. and larger beverage bottles	"	"
8 oz. and larger containers in general	01/01/92	01/01/93
8 oz. and larger non-beverage bottles	01/01/93	01/01/94

The department of agriculture, trade and consumer protection created an advisory committee to help formulate these rules. The committee consisted of recyclers, plastics industry representatives, container manufacturers, plastic container users and representatives of environmental groups. It reviewed a variety of rule drafts and approved the content of this order. Changes to s. 100.33, Stats., in the 1989-91 biennial budget bill and in the 1990

recycling bill (1989 Wisconsin Act 335) caused the department to redraft these rules before submitting them for legislative committee review. The rules define the scope of s. 100.33, Stats., establish proper labeling requirements and create a method by which container manufacturers can seek an exemption from the labeling requirements.

The order specifies what plastic containers are covered by the law. It states that plastic cups are considered "cartons" (a type of container included within the statutory definition of "plastic container") and must be labeled like other plastic containers, if their original use will be to hold a product for retail sale. The order excludes container lids, trays used to hold meat or other foods for retail sale and plastic one-half pint, one pint or one quart baskets used to hold berries or other foods for retail sale.

The order requires all regulated plastic containers to be labeled with a triangular symbol and a code for identifying the plastic resin used in the container. The label can be molded, imprinted or otherwise attached to the container, in conformity with the requirement in s. 100.33 (2), Stats., that manufacturers and persons placing products in plastic containers be able to "choose an appropriate method of labeling plastic containers". Inside the triangle must be placed a number and below the triangle a series of letters identifying the resin used, as follows:

- (a) For polyethylene terephthalate, "1" and "PETE".
- (b) For high density polyethylene, "2" and "HDPE".
- (c) For polyvinyl chloride, "3" and "V".
- (d) For low density polyethylene, "4" and "LDPE".
- (e) For polypropylene, "5" and "PP".
- (f) For polystyrene, "6" and "PS".
- (g) For combinations of resins or other resins, "7" and "OTHER".

Generally, plastic containers not entirely composed of a single resin must be labeled "7" and "OTHER". Plastic containers whose labels or base cups are composed of different resins, though, may be labeled according to the container's principal resin. For example, soda bottles are principally made of polyethylene terephthalate, but they also include a base cup of a different resin. This order allows soda bottles to be labeled "1" and "PETE".

The triangle in the symbol must be at least one-half inch high and the numbers and letters must be at least one-fourth the height of the triangle, unless the plastic container is designed such that a label of this size cannot be added to it. If so, a smaller label may be used, but it must be easily read at a glance.

The order relies primarily on the plastic container coding system developed by the national society of the plastics industry,

practicable, with national industry-wide plastic container coding systems". Section 100.33 (2), Stats.

The order allows the department to grant a variance from labeling requirements if the person requesting a variance can prove it is technologically impossible to label a particular type of plastic container. Under s. 100.33 (3m), Stats., such variances initially last up to one year but may be renewed.

-----

SECTION 1. Chapter Ag 57 is created to read:

CHAPTER Ag 57  
LABELING PLASTIC CONTAINERS FOR  
RECYCLING, RECLAMATION AND REUSE

Ag 57.01 AUTHORITY. This chapter is promulgated pursuant to s. 100.33, Stats.

Ag 57.03 DEFINITIONS. The definitions set forth in s. 100.33, Stats., apply to this chapter. For the purpose of interpreting s. 100.33, Stats., and this chapter:

(1) "Carton" includes an individual, separate, rigid plastic cup, if the cup is originally used to contain a product that is the subject of a retail sale.

(2) "Container" does not include:

(a) A container's lid.

(b) A tray originally used to contain meat or other foods for retail sale.

(c) A one quart or smaller mesh basket originally used to contain berries or other foods for retail sale.

(d) A container used to hold pesticides.

(3) "Department" means the department of agriculture, trade and consumer protection.

(4) "Rigid" means relatively inflexible and self-supporting when empty.

NOTE: The above definitions provide additional detail to the larger definition of "plastic container" in s. 100.33 (1) (c), Stats., which is as follows:

100.33 (1) (c) "Plastic container" means an individual, separate, rigid plastic bottle, can, jar or carton, except for a blister pack, that is originally used to contain a product that is the subject of a retail sale, as defined under s. 100.30 (2) (h).

Section 100.33 (1) (ad), Stats., defines "blister pack" as a "container in which an item has a covering of plastic film or preformed semirigid plastic and the covering is affixed to a rigid backing." Blister packs are used to package various items, such as lunch meat, hardware and sporting goods that are displayed by hanging the blister packs from hooks.

Under the definition of "plastic container", empty plastic cups sold at retail (such as those sold in quantities of 50 for picnics) are not required to be labeled because they are not "originally used to contain a product that is the subject of a retail sale". On the other hand, empty plastic cups a wholesaler sells to a retailer, which the retailer will fill in order to sell a beverage, must be labeled.

Plastic containers used to hold pesticides can be recycled, but only in accordance with the pesticide label's directions. In most situations, containers holding pesticides cannot be reused. See ch. Ag 29 for other rules regarding pesticide use and disposal.

Ag 57.05 LABELING. (1) TRIANGULAR SYMBOL. Each plastic container regulated under this chapter and under s. 100.33, Stats., shall have a triangular symbol molded, imprinted or otherwise attached. Inside the triangle shall be a number and below the triangle shall be a series of letters identifying the resin used in the plastic container, as specified in sub. (2).

(2) IDENTIFICATION OF RESIN. To identify the resin used in a plastic container, the following codes are required as part of the symbol under sub. (1):

(a) If the plastic container is made of polyethylene

terephthalate, the number "1" and the letters "PETE" with the symbol.

(b) If the plastic container is made of high density polyethylene, the number "2" and the letters "HDPE" with the symbol.

(c) If the plastic container is made of polyvinyl chloride, the number "3" and the letter "V" with the symbol.

(d) If the plastic container is made of low density polyethylene, the number "4" and the letters "LDPE" with the symbol.

(e) If the plastic container is made of polypropylene, the number "5" and the letters "PP" with the symbol.

(f) If the plastic container is made of polystyrene, the number "6" and the letters "PS" with the symbol.

(g) If the plastic container is made of other resins or of multiple resins, the number "7" and the word "OTHER" with the symbol. A plastic container whose label or base cup is composed of a different resin shall be labeled according to the container's principal resin.

(3) LABEL SIZE. (a) Except as provided in par. (b), the height of the triangle required under sub. (1) shall be at least one-half inch. The numbers and letters required under sub. (2) shall be at least one-fourth the height of the triangle.

(b) If a plastic container is designed such that a label of the size specified in par. (a) cannot be added to it, a smaller label may be used, if the label can be easily read at a glance.

NOTE: Using a recycling symbol would satisfy the requirement that a triangular symbol be incorporated in

the label, such as the following examples shown below. A simple triangle can be substituted for the recycling arrows.



LDPE



PS



HDPE

The prohibition against selling unlabeled plastic containers in s. 100.33, Stats., applies to sales and offers to sell made by manufacturers, distributors, those who place products in regulated plastic containers and retailers. The law does not specifically impose the duty to label on any one of these parties, but s. 100.33 (2), Stats., conveys an intent that primary labeling responsibility will fall first on plastic container manufacturers and next on those who place products in plastic containers.

Aq 57.07 VARIANCES. The department may grant a variance from this chapter, as provided in s. 100.33 (3m), Stats., if the requester can prove that labeling a type of plastic container is technologically impossible.

Aq 57.11 PENALTY. Each violation of these rules is subject to a forfeiture of not more than \$500, as provided in s. 100.33 (4), Stats. Each day of violation constitutes a separate offense.

NOTE: Section 100.33 (3), Stats., staggers the dates when the labeling requirements for plastic containers first apply:

<u>Type and Size of Container</u>	<u>Eff. Date Wholesale Sales</u>	<u>Eff. Date Retail Sales</u>
16 oz. and larger containers in general	01/01/91	01/01/92
16 oz. and larger non-beverage bottles	"	"
8 oz. and larger beverage bottles	"	"
8 oz. and larger containers in general	01/01/92	01/01/93
8 oz. and larger non-beverage bottles	01/01/93	01/01/94

SECTION 2. EFFECTIVE DATE. This rule shall take effect on the first day of the month following publication in the Wisconsin administrative register, as provided in s. 227.22 (2) (intro.), Stats.

Dated this 10<sup>th</sup> day of October, 1990.

STATE OF WISCONSIN  
DEPARTMENT OF AGRICULTURE,  
TRADE AND CONSUMER PROTECTION

By Donald J. Soberg  
Donald J. Soberg, Administrator  
Trade & Consumer Protection Division

RHP/jkm/Ag57/020/T5  
10/5/90

MARKETING; TRADE PRACTICES

100.33

whether in the form of mix or finished ice cream and ice milk. Products upon which fees have been paid shall be exempt from further fees in successive transactions. Any person claiming that products sold by the person are not subject to assessment under this subsection by reason of the fact that they were not sold or resold within the state shall have the burden of so proving, and shall be obligated to pay assessment on such products unless and until the person produces records satisfying the department that such products are not subject to assessment.

★ ★ ★ ★ ★ ● ★

History—

Subsec. (6)(a) amended by—  
1987 Act 399, § 366, eff. July 1, 1988.

100.30. Unfair sales act

● ★ ★ ★ ★ ★ ★

(2m) Definitions; construction. (a) When one or more items of merchandise are furnished or sold in combination with or on condition of the purchase of one or more other items, or are so advertised, all items shall be included in determining cost under sub. . . . (2)(a) or (c); and if any of the items included therein are separately priced, such separate price shall be subject to the requirements of this section.

(b) Any retailer who also sells to other retailers shall use the invoice cost to other retailers in computing the selling price at retail under sub. . . . (2)(a); and if that retailer is a manufacturer or producer, both sub. . . . (2)(a) and (c) shall be used in computing the selling price at retail. In the absence of sales to other retailers, the manufacturer's or producer's invoice cost to wholesalers shall be used in computing the manufacturer's or producer's selling price at retail as provided in sub. . . . (2)(a) and (c).

● ★ ★ ★ ● ★ ●

Law Revision Committee Notes—1987 Act 175, § 2

Section 100.30(2m), stats., was renumbered by 1983 Wisconsin Act 189. The cross-references were amended incorrectly in that act. This amendment corrects the cross-references.

History—

Subsec. (2m) amended by—  
1987 Act 175, § 2, eff. April 1, 1988.

100.33. Plastic container labeling

- (1) Definitions. In this section:
  - (a) "Labeling" means attaching information to or embossing or printing information on a plastic container.
  - (b) "Material recovery" means the reuse, recycling, reclamation, composting or other . . . recovery of useful materials from solid waste, with or without treatment.
  - (c) "Plastic container" means an individual, separate, rigid plastic bottle, can, jar or carton that is originally used to contain a product that is the subject of a retail sale, as defined under s. 100.30(2)(h).
  - (d) "Reclamation" means the treatment of solid waste and its return to productive use in a form or for a use that is different from its original form or use.
  - (e) "Recycling" means the treatment of solid waste and its return to productive use in a form and for a use that is the same as or similar to the original form and use.
  - (f) "Reuse" means the return of solid waste to productive use without treatment and without changing its form or use.

Additions in text are indicated by underline; deletions by asterisks . . .

7



(2) Labeling rules required. The department shall promulgate rules establishing labeling requirements for plastic containers. The requirements shall be designed to provide information needed by operators of material recovery programs to facilitate the recycling, reclamation or reuse of plastic containers. The rules promulgated under this subsection shall permit a manufacturer of plastic containers and a person who places products in plastic containers to choose an appropriate method of labeling plastic containers. The department shall make an effort to develop rules which are consistent, to the greatest extent practicable, with national industry-wide plastic container coding systems. The rules shall exempt from the labeling requirements plastic containers that are readily identifiable because of their appearance and plastic containers for which there is no technological capability for recycling, reclamation or reuse or for which recycling, reclamation or reuse is not economically feasible. The rules may exempt from the labeling requirements plastic containers of a capacity of less than a specified minimum size. In determining the types of plastic containers to exempt from the labeling requirements, the department shall consult with the department of natural resources.

(3) Prohibition. On and after January 1, 1990, no person may sell or offer for sale in this state a plastic container or a product in a plastic container that does not comply with the labeling requirements under sub. (2).

(4) Penalty. Any person who violates sub. (3) shall forfeit not more than \$500 for each violation. Each day of violation constitutes a separate offense.

**Source:**

1987 Act 293, § 1, eff. April 26, 1988.  
1987 Act 403, § 113, eff. June 7, 1988.

**1987 Legislation:**

1987 Act 293, § 2m provides:

"(1) Plastic container labeling. The department of agriculture, trade and consumer protection shall establish an advisory committee under

section 227.13 of the statutes to advise the department on the drafting of rules under section 100.33 of the statutes, as created by this act. The advisory committee shall consist of representatives of the plastics industry, manufacturers of plastic containers, retailers, plastic recyclers, environmental or citizens groups, and any other persons affected by or interested in the subject matter of the rules."

## CHAPTER 101. DEPARTMENT OF INDUSTRY, LABOR AND HUMAN RELATIONS

### SUBCHAPTER I. REGULATION OF INDUSTRY: GENERAL PROVISIONS

Section	Section
101.08. Fluorescent lamp ballast energy efficiency. [New]	101.143. Petroleum storage remedial action. [New]
	101.35. Pilot Wisconsin job opportunity business subsidy program. [New]

#### WESTLAW Electronic Research

WESTLAW supplements Wisconsin Statutes Annotated and is useful for additional research. Enter a citation in Insta-Cite for display of any parallel citations and case history. Enter a constitution, statute or rule citation in a case law database for cases of interest.

Example query for Insta-Cite: IC 368 N.W.2d 830

Example query for Wisconsin Constitution:  
W.S.A.Const. Wis.Const. Const. Constitution /s 1 I +3 9

Example query for statute: 402.513

Also, see WESTLAW Electronic Research Guide following the Preface.

June 10, 1989

Amendment to s. 100.33  
Plastic Container Labeling  
Effective Dates

SECTION 1. 100.33 (1) (a) of the statutes is renumbered 100.33 (1) (ar).

SECTION 2. 100.33 (1) (a) of the statutes is created to read:  
100.33 (1) (a) "Beverage" has the meaning provided in s. 134.77 (1) (a).

SECTION 3. 100.33 (1) (ag) of the statutes is created to read:

100.33 (1) (ag) "Bottle" means a plastic container whose neck is smaller than its body, with a screw-on or press-on lid.

SECTION 4. 100.33 (1) (g) of the statutes is created to read:  
100.33 (1) (g) "Sale at retail" has the meaning provided in s. 100.30 (2) (h).

SECTION 5. 100.33 (1) (h) of the statutes is created to read:  
100.33 (1) (h) "Sale at wholesale" has the meaning provided in s. 100.30 (2) (i).

SECTION 6. 100.30 (2) of the statutes is amended to read:

100.33 (2) LABELING RULES REQUIRED. The department shall promulgate rules establishing labeling requirements for plastic containers. The requirements shall be designed to provide information needed by operators of material recovery programs to facilitate the recycling, reclamation or reuse of plastic containers. The rules promulgated under this subsection shall permit a manufacturer of plastic containers and a person who places products in plastic containers to choose an appropriate method of

labeling plastic containers. The department shall make an effort to develop rules which are consistent, to the greatest extent practicable, with national industry-wide plastic container coding systems. The rules shall exempt from the labeling requirements plastic containers that are readily identifiable because of their appearance and plastic containers for which there is no technological capability for recycling, reclamation or reuse or for which recycling, reclamation or reuse is not economically feasible. ~~The rules may exempt from the labeling requirements plastic containers of a capacity of less than a specified minimum size.~~ In determining the types of plastic containers to exempt from the labeling requirements, the department shall consult with the department of natural resources.

SECTION 7. 100.33 (3) of the statutes is repealed and recreated to read:

100.33 (3) PROHIBITION. (a) Sale of plastic beverage bottles. On and after January 1, 1991, no person may sell or offer for sale in this state at wholesale a plastic beverage bottle with a capacity of 8 fluid ounces or more, or a beverage in such a plastic bottle, unless the bottle complies with the labeling requirements under sub. (2). On and after January 1, 1992, no person may sell or offer for sale in this state at retail a plastic beverage bottle with a capacity of 8 fluid ounces or more, or a beverage in such a plastic bottle, unless the bottle complies with the labeling requirements under sub. (2).

(b) Sale of other plastic bottles. 1. On and after January

1, 1991, no person may sell or offer for sale in this state at wholesale any plastic bottle with a capacity of 16 fluid ounces or more, or a product in such a plastic bottle, unless the bottle complies with the labeling requirements under sub. (2). On and after January 1, 1992, no person may sell or offer for sale in this state at retail any plastic bottle with a capacity of 16 fluid ounces or more, or a product in such a plastic bottle, unless the bottle complies with the labeling requirements under sub. (2).

2. On and after January 1, 1993, no person may sell or offer for sale in this state at wholesale any plastic bottle with a capacity of 8 fluid ounces or more, or a product in such a plastic bottle, unless the bottle complies with the labeling requirements under sub. (2). On and after January 1, 1994, no person may sell or offer for sale in this state at retail any plastic bottle with a capacity of 8 fluid ounces or more, or a product in such a plastic bottle, unless the bottle complies with the labeling requirements under sub. (2).

3. Subdivisions 1 and 2 do not apply to the sale or offer to sell of plastic beverage bottles or beverages in plastic bottles.

(c) Sale of all other plastic containers. 1. On and after January 1, 1991, no person may sell or offer for sale in this state at wholesale any plastic container with a capacity of 16 fluid ounces or more, or a product in such a plastic container, unless the container complies with the labeling requirements under sub. (2). On and after January 1, 1992, no person may sell or offer for sale in this state at retail any plastic container with a capacity

of 16 fluid ounces or more, or a product in such a plastic container, unless the container complies with the labeling requirements under sub. (2).

2. On and after January 1, 1992, no person may sell or offer for sale in this state at wholesale any plastic container with a capacity of 8 fluid ounces or more, or a product in such a plastic container, unless the container complies with the labeling requirements under sub. (2). On and after January 1, 1993, no person may sell or offer for sale in this state at retail any plastic container with a capacity of 8 fluid ounces or more, or a product in such a plastic container, unless the container complies with the labeling requirements under sub. (2).

3. Subdivisions 1 and 2 do not apply to the sale or offer to sell of any plastic bottles or any products in plastic bottles.

(End)



## Western Region

Alaska, Arizona, California, Colorado,  
Hawaii, Oklahoma, Texas



—  
—  
—

—  
—  
—



## ALASKA

1. **Compliance Date:** July 1, 1991
2. **Scope:** Containers manufactured, sold, or offered for sale in Alaska:

<u>Type</u>	<u>Size</u>
<p><u>Rigid Plastic Containers</u> -- Formed or molded container, intended for single use, composed predominantly of plastic resin, relatively inflexible, finite shape.</p>	8 ounces to 5 gallons †
<p><u>Plastic Bottles</u> -- Plastic container intended for single use; has a neck smaller than its body; accepts screw-top, snap-cap, or other closure.</p>	16 ounces to 5 gallons †

3. **Required Codes:**

<u>Resin Type</u>	<u>Code Number</u> †	<u>Code Letters</u> †
Polyethylene Terephthalate	1	PETE
High Density Polyethylene	2	HDPE
Vinyl	3	V
Low Density Polyethylene	4	LDPE
Polypropylene	5	PP
Polystyrene	6	PS
Other	7	OTHER

A. Base cups and labels: No provision. †

B. Multilayer: No provision. †

4. **Required Symbol:** RIS; Size not specified.
5. **Type and Location of Symbol:** Molded or imprinted on or near the bottom of the bottle or container.

† Denotes requirements that are consistent with the SPI Voluntary Code

6. **Penalties:** \$50 per violation, not to exceed \$500.

7. **Additional Information:**

Mr. Glenn Miller  
Hazardous and Solid Waste  
Program Manager  
Department of Environmental Conservation  
P.O. Box 0  
Juneau, Alaska 99811-1800  
(907) 465-2671

8. **Attachments:** Alaska Stat. § 46.06.095

† Denotes requirements that are consistent with the SPI Voluntary Code



# LAWS OF ALASKA

1990

**Source**

CSHB 532(Fin) am

**Chapter No.**

61

**AN ACT**

Requiring the placement of certain coding on certain plastic bottles and containers; and providing for an effective date.

---

**BE IT ENACTED BY THE LEGISLATURE OF THE STATE OF ALASKA:**

THE ACT FOLLOWS ON PAGE 1, LINE 10

Approved by the Governor: May 16, 1990  
Actual Effective Date: July 1, 1991

1  
2  
3  
4  
5  
6  
7  
8  
9  
10  
11  
12  
13  
14  
15  
16  
17  
18  
19  
20  
21  
22  
23  
24  
25  
26  
27  
28  
29

AN ACT

Requiring the placement of certain coding on certain plastic bottles and containers; and providing for an effective date.

\* Section 1. AS 46.06 is amended by adding a new section to read:

Sec. 46.06.095. CODING REQUIRED. (a) A person may not manufacture, sell, or offer to sell a plastic bottle or a rigid plastic container unless a code that identifies the type of resin used to produce the bottle or container and that complies with (b) of this section is molded into or imprinted on or near the bottom of the bottle or container.

(b) The department shall establish by regulation the content and design for the code required under (a) of this section. The regulations and further amendments to those regulations shall be consistent with applicable federal requirements concerning plastic product labeling. Prior to the establishment of any applicable federal requirements concerning plastic product labeling, the department shall use the codification system designed by the Society of the Plastics Industry, Inc., including the following features:

(1) a code number placed within an equilateral triangle of arrows, and code letters placed below the triangle of arrows, in which

(A) the triangle is formed by three arrows with the apex of the point of each triangle at the midpoint of each arrow, rounded with a short radius;

Chapter 61

1 (B) the arrowhead of each arrow is at the midpoint of  
2 each side of the triangle with a short gap separating the arrow-  
3 head from the base of the adjacent arrow; and

4 (C) the triangle formed by the arrows depicts a clock-  
5 wise path around the number;

6 (2) the following code numbers and letters to be used in  
7 (1) of this subsection to identify types of resin:

8 (A) 1 and PETE, representing polyethylene terephthal-  
9 ate;

10 (B) 2 and HDPE, representing high density polyethy-  
11 lene;

12 (C) 3 and V, representing vinyl;

13 (D) 4 and LDPE, representing low density polyethylene;

14 (E) 5 and PP, representing polypropylene;

15 (F) 6 and PS, representing polystyrene; and

16 (G) 7 and OTHER, representing all other plastic res-  
17 ins.

18 (c) The department shall maintain a list of the codes estab-  
19 lished under (b) of this section and provide a copy of the list upon  
20 request.

21 (d) A person who violates (a) of this section is subject to a  
22 civil penalty of \$50 for each violation. Penalties imposed under this  
23 subsection for a series of related violations by the same person may  
24 not exceed \$500. The superior court may enjoin a person from violat-  
25 ing (a) of this section.

26 (e) In this section,

27 (1) "plastic" means a material made of polymeric organic  
28 compounds and additives that can be shaped by flow;

29 (2) "plastic bottle" means a plastic container that is  
H

1 intended for single use and that

2 (A) has a neck smaller than the body of the container;

3 (B) accepts a screw-top, snap-cap, or other closure;

4 and

5 (C) has a capacity of not less than 16 fluid ounces or  
6 more than five gallons;

7 (3) "rigid plastic container" means a formed or molded  
8 container that is intended for single use, that is composed predomi-  
9 nately of plastic resin, and that has a relatively inflexible finite  
10 shape or form having a capacity of not less than eight ounces or more  
11 than five gallons; "rigid plastic container" does not include a plas-  
12 tic bottle.

13 \* Sec. 2. This Act takes effect July 1, 1991.

14  
15  
16  
17  
18  
19  
20  
21  
22  
23  
24  
25  
26  
27  
28  
29  
H

## ARIZONA

1. **Compliance Date:** July 1, 1991
2. **Scope:** Containers distributed, sold, or exposed for sale in Arizona:

<u>Type</u>	<u>Size</u>
<u>Rigid Plastic Containers</u> -- Not defined.	8 ounces to 5 gallons †
<u>Plastic Bottles</u> -- Not defined.	16 ounces to 5 gallons †

3. **Required Codes:**

<u>Resin Type</u>	<u>Code Number</u> †	<u>Code Letters</u> †
Polyethylene Terephthalate	1	PETE
High Density Polyethylene	2	HDPE
Vinyl	3	V
Low Density Polyethylene	4	LDPE
Polypropylene	5	PP
Polystyrene	6	PS
Other	7	OTHER

A. Base cups and labels: No provision. †

B. Multilayer: No provision. †

4. **Required Symbol:** RIS
5. **Type and Location of Symbol:** Molded or imprinted label on the bottom of the plastic container product.
6. **Penalties:** No provision.

† Denotes requirements that are consistent with the SPI Voluntary Code

**7. Additional Information:**

Ms. Valarie Backus  
Recycling Coordinator  
Arizona Department of Environmental Quality  
2005 North Central Avenue  
Phoenix, Arizona 85005

**8. Attachments:** Arizona House Bill 2574

† Denotes requirements that are consistent with the SPI Voluntary Code



State of Arizona  
House of Representatives  
Thirty-ninth Legislature  
Second Regular Session  
1990

ISSUED BY  
**JIM SHUMWAY**  
SECRETARY OF STATE

CHAPTER 378  
HOUSE BILL 2574

AN ACT

RELATING TO THE ENVIRONMENT; PROVIDING FOR A SOLID WASTE RECYCLING PROGRAM; PRESCRIBING RECYCLING OPPORTUNITIES TO BE PROVIDED BY CITIES OR TOWNS AND COUNTIES; ESTABLISHING AN ADVISORY COMMITTEE ON RECYCLED MATERIALS MARKETS; PRESCRIBING MEMBERS, DUTIES AND A REPORT; PRESCRIBING DEFINITIONS; PROVIDING FOR A FIVE PER CENT PREFERENCE IN AN AWARD OF A CERTAIN CONTRACT TO BIDDER OFFERING THE RECYCLED PRODUCT; PRESCRIBING SPECIFICATIONS WHICH DO NOT DISCRIMINATE AGAINST USE OF RECYCLED MATERIALS; PROVIDING FOR A STATE AGENCY RECYCLING MATERIALS PROCUREMENT PROGRAM; PRESCRIBING RECYCLING OF WASTEPAPER BY STATE AGENCIES; PRESCRIBING DUTIES OF THE DEPARTMENT OF ADMINISTRATION REGARDING PROCEDURES AND CONTRACTS; PRESCRIBING IMPRINT OF SYMBOL; PRESCRIBING REPORT BY DIRECTOR REGARDING PROCUREMENT PROGRAM DATA AND PROCEDURES; PROVIDING FOR AN ARIZONA RECYCLING PROGRAM; PRESCRIBING ADMINISTRATION BY THE DEPARTMENT OF ENVIRONMENTAL QUALITY; PRESCRIBING POWERS AND DUTIES; PRESCRIBING AN ANNUAL REPORT; PRESCRIBING A PUBLIC EDUCATION PROGRAM; PRESCRIBING THAT THE DEPARTMENT OF ENVIRONMENTAL QUALITY IS THE LEAD AGENCY FOR PROVIDING CERTAIN TECHNICAL ASSISTANCE; PRESCRIBING USE OF RECYCLED NEWSPRINT BY COMMERCIAL CONSUMERS; PRESCRIBING A SCHEDULE FOR PERCENTAGE OF RECYCLED NEWSPAPER TO BE USED; PRESCRIBING CERTIFICATION OF USE AND SUPPLY; PRESCRIBING DATA TO BE MAINTAINED BY THE DIRECTOR OF ENVIRONMENTAL QUALITY; PRESCRIBING STANDARDS FOR NEWSPRINT QUALITY; PRESCRIBING FOR REFERRAL OF CERTAIN CERTIFICATION TO THE ATTORNEY GENERAL FOR PROSECUTION; PRESCRIBING A CIVIL PENALTY; PRESCRIBING RECYCLING OF PLASTICS; PRESCRIBING LABELS; PROVIDING FOR LANDFILL DISPOSAL FEES; PRESCRIBING RECORD KEEPING AND REMITTANCE OF FEES BY PERSONS DISPOSING WASTE IN CERTAIN UNREGULATED FACILITIES; PRESCRIBING NONAPPLICABILITY; PROVIDING FOR A RECYCLING FUND; PRESCRIBING SOURCE, USES AND ALLOCATION OF MONIES; PROVIDING FOR POOLING OF RESOURCES; PROVIDING FOR AN ADVISORY COMMITTEE ON USE OF MONIES IN THE RECYCLING FUND; PRESCRIBING A SURVEY OF THE PAPER INDUSTRY; AMENDING TITLE 9, CHAPTER 4, ARTICLE 8, ARIZONA REVISED STATUTES, BY ADDING SECTION 9-500.06; AMENDING TITLE 11, CHAPTER 2, ARTICLE 4, ARIZONA REVISED STATUTES, BY ADDING SECTION 11-269; AMENDING

1 PUBLIC. A PERSON WHO VIOLATES THIS SECTION IS SUBJECT TO A CIVIL PENALTY  
2 OF NOT MORE THAN ONE THOUSAND DOLLARS.

3 49-805. Recycling of plastics; labels

4 A. THE DEPARTMENT SHALL DEVELOP AND ADMINISTER A PROGRAM TO  
5 ENCOURAGE THE RECYCLING AND PROPER DISPOSAL OF PLASTICS.

6 B. BY JULY 1, 1991, A PERSON SHALL NOT DISTRIBUTE, SELL OR EXPOSE  
7 FOR SALE IN THIS STATE A PLASTIC BOTTLE OF SIXTEEN OUNCES OR MORE UP TO  
8 FIVE GALLONS AND A RIGID PLASTIC CONTAINER OF EIGHT OUNCES OR MORE UP TO  
9 FIVE GALLONS UNLESS THE PRODUCT HAS A MOLDED OR IMPRINTED LABEL INDICATING  
10 THE PLASTIC RESIN USED TO PRODUCE THE PLASTIC CONTAINER PRODUCT. THE  
11 LABEL MUST APPEAR ON THE BOTTOM OF THE PLASTIC CONTAINER PRODUCT AND MUST  
12 BE CLEARLY VISIBLE. THIS LABEL SHALL CONSIST OF A NUMBER PLACED WITHIN  
13 THREE TRIANGULATED ARROWS AND LETTERS PLACED BELOW THE TRIANGLE OF ARROWS.  
14 THE TRIANGLE SHALL BE EQUILATERAL, FORMED BY THREE ARROWS WITH THE APEX OF  
15 EACH POINT OF THE TRIANGLE AT THE MIDPOINT OF EACH ARROW, ROUNDED WITH A  
16 SHORT RADIUS. THE POINTER OF EACH ARROW SHALL BE AT THE MIDPOINT OF EACH  
17 SIDE OF THE TRIANGLE WITH A SHORT GAP SEPARATING THE POINTER FROM THE BASE  
18 OF THE ADJACENT ARROW. THE TRIANGLE FORMED BY THE THREE ARROWS CURVED AT  
19 THEIR MIDPOINTS SHALL DEPICT A CLOCKWISE PATH AROUND THE CODE NUMBER. THE  
20 NUMBER AND LETTERS SHALL BE AS FOLLOWS:

21 1. FOR POLYETHYLENE TEREPHTHALATE, THE LETTERS "PETE" AND THE  
22 NUMBER "1".

23 2. FOR HIGH DENSITY POLYETHYLENE, THE LETTERS "HDPE" AND THE NUMBER  
24 "2".

25 3. FOR VINYL, THE LETTER "V" AND THE NUMBER "3".

26 4. FOR LOW DENSITY POLYETHYLENE, THE LETTERS "LDPE" AND THE NUMBER  
27 "4".

28 5. FOR POLYPROPYLENE, THE LETTERS "PP" AND THE NUMBER "5".

29 6. FOR POLYSTYRENE, THE LETTERS "PS" AND THE NUMBER "6".

30 7. FOR ANY OTHER, THE WORD "OTHER" AND THE NUMBER "7".

31 49-806. Landfill disposal fees

32 A. A DISPOSAL FEE OF TWENTY-FIVE CENTS IS IMPOSED FOR EACH SIX  
33 CUBIC YARDS OF UNCOMPACTED SOLID WASTE, TWENTY-FIVE CENTS FOR EACH THREE  
34 CUBIC YARDS OF COMPACTED SOLID WASTE OR TWENTY-FIVE CENTS PER TON OF SOLID  
35 WASTE RECEIVED AT LANDFILLS REGULATED BY THE DEPARTMENT. EACH OPERATOR OF  
36 A SOLID WASTE DISPOSAL FACILITY SHALL MAKE THE FEE PAYMENT QUARTERLY. THE  
37 FEE SHALL BE PAID TO THE DEPARTMENT, AFTER COLLECTION, ON OR BEFORE APRIL  
38 20, JULY 20, OCTOBER 20 AND JANUARY 20 FOR THE THREE MONTHS WHICH END ON  
39 THE LAST DAY OF MARCH, JUNE, SEPTEMBER AND DECEMBER.

40 B. EACH FEE PAYMENT SHALL BE ACCOMPANIED BY A FORM PREPARED AND  
41 FURNISHED BY THE DEPARTMENT AND COMPLETED BY THE OPERATOR. THE FORM SHALL  
42 STATE THE TOTAL VOLUME OF SOLID WASTE DISPOSED OF AT THAT FACILITY DURING  
43 THE PAYMENT PERIOD AND SHALL PROVIDE ANY OTHER INFORMATION DEEMED  
44 NECESSARY BY THE DEPARTMENT. THE FORM SHALL BE SIGNED BY THE OPERATOR.

45 C. A PERSON WHO FOR A FEE DISPOSES OF WASTE IN A SOLID WASTE  
46 FACILITY NOT REGULATED BY THE DEPARTMENT SHALL KEEP ACCURATE RECORDS OF  
47 THE WASTE DISPOSED OF IN THOSE LANDFILLS AND REMIT A FEE TO THE DEPARTMENT  
48 AT THE SAME RATE AND IN THE SAME MANNER AS PROVIDED IN SUBSECTION A.

## CALIFORNIA

1. **Compliance Date:** January 1, 1992
2. **Scope:** Rigid plastic (not limited to thermoplastics) containers intended primarily for single service use sold in California:

<u>Type</u>	<u>Size</u>
<u>Rigid Plastic Containers</u> -- Relatively inflexible finite shape comprised predominantly of plastic resin; does not include bottles.	8 ounces to 5 gallons †
<u>Plastic Bottles</u> -- Plastic containers with neck smaller than its body.	16 ounces to 5 gallons †

3. **Required Codes:**

<u>Resin Type</u>	<u>Code Number</u> †	<u>Code Letters</u> †
Polyethylene Terephthalate	1	PETE
High Density Polyethylene	2	HDPE
Vinyl	3	V
Low Density Polyethylene	4	LDPE
Polypropylene	5	PP
Polystyrene	6	PS
Other	7	OTHER

- A. Base cups and labels: Rigid plastic bottles or rigid plastic containers with labels and base cups of a different material shall be coded by the basic material. †
- B. Multilayer: Include as "7-OTHER" unless the bottle or container is composed of more than one layer of a single resin. In that case, the resin specific code must be used and a "7" must be added below the resin abbreviation.

4. **Required Symbol:** RIS; Size not specified. †

† Denotes requirements that are consistent with the SPI Voluntary Code

5. **Type and Location of Code:** Molded on the bottom of bottle or container.
6. **Penalties:** Manufacture for use in California of any rigid plastic container which is not labeled in accordance with this law is a crime with a penalty of \$1,000. [Comment: There is no penalty for selling a container that has not been coded].
7. **Additional Information:**

Mr. Russel Lo Bue  
Division of Recycling  
Department of Conservation  
1025 P Street  
Room 449  
Sacramento, California 95814  
(916) 473-2761

8. **Attachments:** CAL. PUB. RES. CODE §§ 18000-18017  
(Deering 1989), January 1, 1989  
Assembly Bill No. 952

† Denotes requirements that are consistent with the SPI Voluntary Code

stop making convenience incentive payments if another recycling center is willing to certify operation within the convenience zone without receiving payments pursuant to this section.

(6) If a convenience incentive payment to a certified recycling center located in a convenience zone exceeds eight hundred dollars (\$800) per month, the department shall review the convenience zone to determine if the convenience zone should be exempted pursuant to Section 14571.8.

(b) The department shall conduct a study on use of each of the payment mechanisms authorized by subdivision (b) and on use of bonds, grants, and loans authorized by Section 14584 and report to the Legislature on or before January 1, 1989, on the effectiveness of each of these mechanisms.

(c) The department may authorize prepayment of convenience incentive payments to recycling centers pursuant to subdivision (a) for periods of up to one year at a time.

Amended Stats 1987 ch 258 § 16, effective July 27, 1987. Amended Stats 1988 ch 1528 sec 30, effective September 29, 1988.

**Amendments:**

1987 Amendment: Deleted former subd (a)(7) which read: "(7) The department shall stop making convenience incentive payments if another recycling center is willing to redeem containers within the convenience zone without payments pursuant to this section."

Note—For legislative findings and declarations, see 1988 Note following Pub Res C § 14501.

Review of selected 1987 legislation. 19 Pacific LJ 598.

## DIVISION 12.7

### *Plastic Waste*

[Added Stats 1988 ch 838 sec 1.]

- Chapter 1. Legislative Findings. § 18000  
 2. Containers and Packaging. §§ 18010-18017

#### CHAPTER 1

##### *Legislative Findings*

##### § 18000. Legislative findings and declarations

The Legislature finds and declares the following:

- (a) Facilitating the recycling of plastics is in the best interests of the state.  
 (b) This division is intended to require all plastic products sold in California on and after January 1, 1992, to have a molded label indicating the plastic resin used to produce the product.

Added Stats 1988 ch 838 sec 1.

#### CHAPTER 2

##### *Containers and Packaging*

- § 18010. "Rigid plastic container"  
 § 18011. "Rigid plastic bottle"  
 § 18012. "Label"  
 §§ 18013, 18014. [No sections of these numbers]  
 § 18015. Required labels and codes; List of abbreviations used on labels  
 § 18016. Violation; Fine  
 § 18017. Report to Legislature

**§ 18010. "Rigid plastic container"**

"Rigid plastic container" means any formed or molded article comprised predominantly of plastic resin and having a relatively inflexible finite shape or form intended primarily as a single service container with a capacity of eight ounces or more and less than five gallons.

Added Stats 1988 ch 838 sec 1.

**§ 18011. "Rigid plastic bottle"**

"Rigid plastic bottle" means any rigid plastic container with a neck that is smaller than the container body with a capacity of 16 ounces or more and less than five gallons.

Added Stats 1988 ch 838 sec 1.

**§ 18012. "Label"**

"Label" means a code label described in Section 18015 molded into the bottom of the plastic product.

Added Stats 1988 ch 838 sec 1.

**§§ 18013, 18014. [No sections of these numbers]****§ 18015. Required labels and codes; List of abbreviations used on labels**

(a) All rigid plastic bottles and rigid plastic containers sold in California on and after January 1, 1992, shall be labeled with a code which indicates the resin used to produce the rigid plastic bottle or rigid plastic container. Rigid plastic bottles or rigid plastic containers with labels and basecaps of a different material shall be coded by their basic material. The code shall consist of a number placed inside a triangle, and letters placed below the triangle. The triangle shall be equilateral, formed by three arrows with the apex of each point of the triangle at the midpoint of each arrow, rounded with a short radius. The pointer (arrowhead) of each arrow shall be at the midpoint of each side of the triangle with a short gap separating the pointer from the base of the adjacent arrow. The triangle, formed by the three arrows curved at their midpoints shall depict a clockwise path around the code number. The numbers and letters used shall be as follows:

- 1 = PETt (polyethylene terephthalate)
- 2 = HDPE (high density polyethylene)
- 3 = V (vinyl)
- 4 = LDPE (low density polyethylene)
- 5 = PP (polypropylene)
- 6 = PS (polystyrene)
- 7 = OTHER (includes multilayer)

(b) A "7" shall appear below the resin abbreviation when the bottle or container is composed of more than one layer of that resin.

(c) On and after January 1, 1989, the Division of Recycling of the Department of Conservation shall maintain a list of abbreviations used on labels pursuant to subdivision (a) and shall provide a copy of that list to any person upon request.

Added Stats 1988 ch 838 sec 1

**§ 18016. Violation; Fine**

On and after January 1, 1992, it is unlawful to manufacture for use in this state any rigid plastic container which is not labeled in accordance with Section 18015. A violation of this section is a crime punishable by a fine of one thousand dollars (\$1,000).

Added Stats 1988 ch 838 sec 1.

**§ 18017. Report to Legislature**

The Legislative Analyst shall review compliance with this chapter and shall submit a report of its evaluation to the Legislature on or before January 1, 1993.

Added Stats 1988 ch 838 sec 1.

**§ 21000 and following sections—general references:**

Witkin Summary (9th ed) Real Property §§ 58, 61, 87.

California water for national forests: Reserved rents, riparian rights, and instream appropriations. (1987) 20 UCD LR 921.

Courts v planning: The anatomy of four land-use planning conflicts in California. (1987) 15 Western St LR 1.

The Legislature intended that the California Environmental Quality Act (Pub. Resources Code, § 21050 et seq.) be interpreted in such a manner as to afford the fullest possible protection to the environment within the reasonable scope of the statutory language. *City of Livermore v Local Agency Formation Com.* (1986, 1st Dist) 184 Cal App 3d 531.

As applied to private projects, the purpose of the California Environmental Quality Act (Pub. Resources Code, § 21000 et seq.) is to minimize the adverse effects of new construction on the environment. To serve this goal, the act requires assessment of environmental consequences where government has the authority through its regulatory powers to eliminate or mitigate one or more adverse environmental consequences a study could reveal. *Friends of Westwood, Inc. v City of Los Angeles* (1987, 2d Dist) 191 Cal App 3d 259, 235 Cal Rptr 788.

The California Environmental Quality Act (CEQA) (Pub. Resources Code, § 21000 et seq.) must be interpreted in such a manner as to afford the fullest possible protection to the environment

within the reasonable scope of the statutory language. Since the act applies only to projects of a discretionary, rather than a ministerial, character (Pub. Resources Code, § 21080), doubts whether a project is discretionary or ministerial should be resolved in favor of a finding that it is discretionary. Further, where a project is of a hybrid discretionary ministerial character, CEQA applies even if the project is largely ministerial. *Friends of Westwood, Inc. v City of Los Angeles* (1987, 2d Dist) 191 Cal App 3d 259, 235 Cal Rptr 788.

Local agencies must prepare an environmental impact report (EIR) on any project which may have a significant effect on the environment (Pub. Resources Code, § 21151). The word "may" connotes a reasonable possibility. Moreover, the Legislature intended the California Environmental Quality Act (Pub. Resources Code, § 21000 et seq.) to be interpreted in such manner as to afford the fullest possible protection to the environment within the reasonable scope of the statutory language. This principle of interpretation demands a low threshold requirement for preparation of an EIR. *Sundstrom v County of Mendocino* (1988, 1st Dist) 202 Cal App 3d 296, 248 Cal Rptr 352.

**§ 21000. Declaration of legislative findings and intent**

Witkin Summary (9th ed) Real Property § 58.

**1. In General**

The fundamental objective of the California Environmental Quality Act (Pub. Resources Code, § 21000 et seq.) (CEQA) is to ensure that environmental considerations play a significant role in governmental decisionmaking. To facilitate CEQA's informational role, the environmental im-

port report must contain facts and analysis, not just the agency's bare conclusions and opinions, so as to enable the decisionmakers and the public to make an independent, reasoned judgment about a proposed project. Public participation is an essential part of the CEQA process, and a project must be open for public discussion and agency modifica-

Assembly Bill No. 952

CHAPTER 37

An act to amend Section 18015 of the Public Resources Code, relating to plastic containers, and declaring the urgency thereof, to take effect immediately.

[Approved by Governor June 7, 1989. Filed with Secretary of State June 8, 1989.]

LEGISLATIVE COUNSEL'S DIGEST

AB 952, Killea. Rigid plastic containers: coding.

Existing law requires all rigid plastic bottles, as defined, and all rigid plastic containers, as defined, sold in California on and after January 1, 1992, to be labeled with a specified code which indicates the resin used, including the code "PETt" for polyethylene terephthalate.

This bill would change that code to "PETE."

The bill would declare that it is to take effect immediately as an urgency statute.

*The people of the State of California do enact as follows:*

SECTION 1. Section 18015 of the Public Resources Code is amended to read:

18015. (a) All rigid plastic bottles and rigid plastic containers sold in California on and after January 1, 1992, shall be labeled with a code which indicates the resin used to produce the rigid plastic bottle or rigid plastic container. Rigid plastic bottles or rigid plastic containers with labels and basecaps of a different material shall be coded by their basic material. The code shall consist of a number placed inside a triangle, and letters placed below the triangle. The triangle shall be equilateral, formed by three arrows with the apex of each point of the triangle at the midpoint of each arrow, rounded with a short radius. The pointer (arrowhead) of each arrow shall be at the midpoint of each side of the triangle with a short gap separating the pointer from the base of the adjacent arrow. The triangle, formed by the three arrows curved at their midpoints shall depict a clockwise path around the code number. The numbers and letters used shall be as follows:

- 1 = PETE (polyethylene terephthalate)
- 2 = HDPE (high density polyethylene)
- 3 = V (vinyl)
- 4 = LDPE (low density polyethylene)
- 5 = PP (polypropylene)
- 6 = PS (polystyrene)
- 7 = OTHER (includes multilayer)



(b) A "7" shall appear below the resin abbreviation when the bottle or container is composed of more than one layer of that resin.

(c) On and after January 1, 1989, the Division of Recycling of the Department of Conservation shall maintain a list of abbreviations used on labels pursuant to subdivision (a) and shall provide a copy of that list to any person upon request.

SEC. 2. This act is an urgency statute necessary for the immediate preservation of the public peace, health, or safety within the meaning of Article IV of the Constitution and shall go into immediate effect. The facts constituting the necessity are:

The code for polyethylene terephthalate, as contained in Section 18015 of the Public Resources Code, is in conflict with an existing trademark, and, since container manufacturers are required to code all applicable plastic containers on or before January 1, 1992, it is necessary that this act take effect immediately to provide sufficient time for compliance.

O

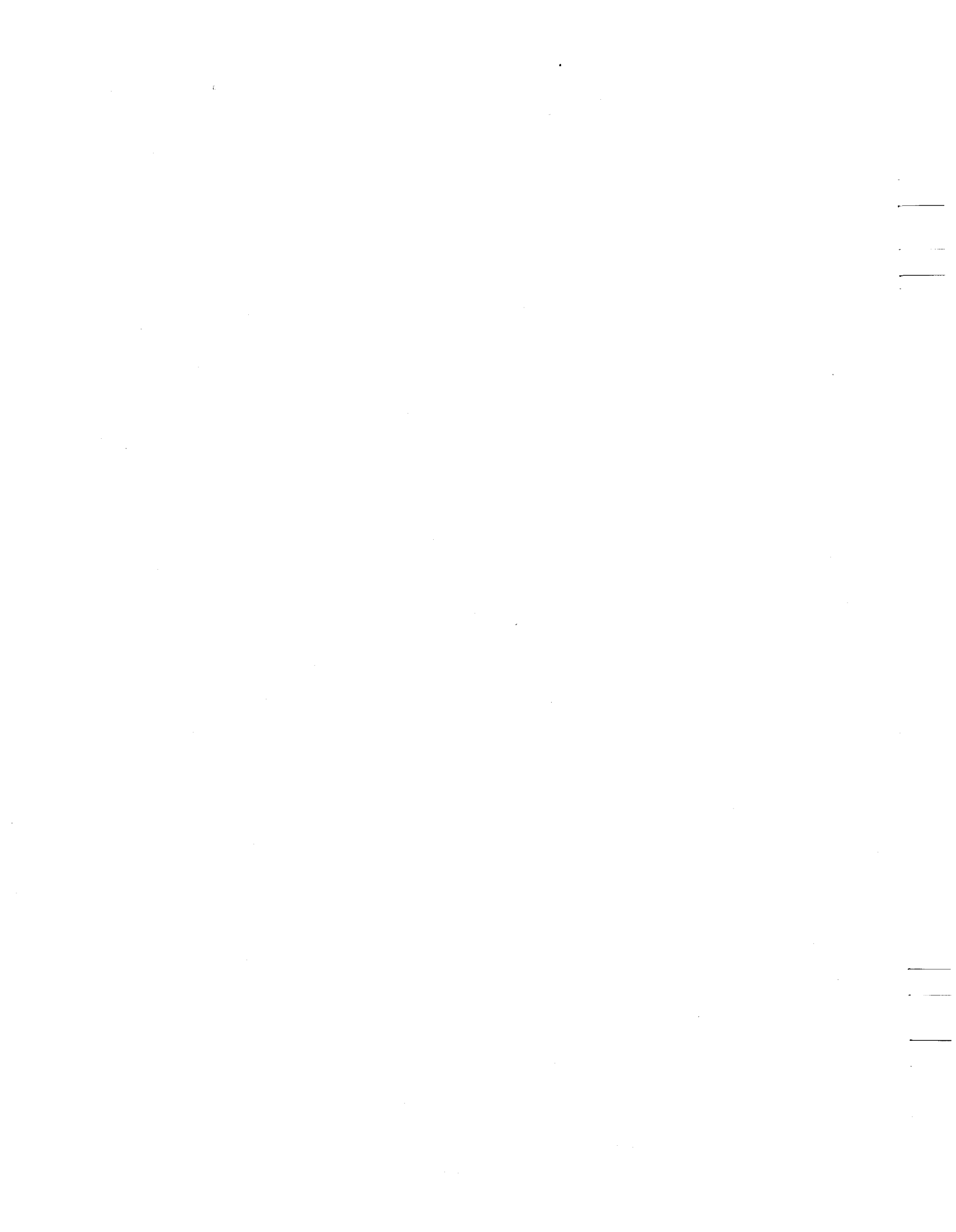

## COLORADO

1. **Compliance Date:** July 1, 1992; automatically repealed effective July 1, 1994.
2. **Scope:** Rigid plastic containers intended primarily for single service use that can be shaped by flow manufactured on or after July 1, 1992, that are distributed, sold or offered for sale in Colorado:

<u>Type</u>	<u>Size</u>
<u>Rigid Plastic Containers</u> -- Relatively inflexible finite shape comprised predominantly of plastic resin unless it is a plastic bottle.	8 ounces to 5 gallons †
<u>Plastic Bottles</u> -- Plastic container with neck smaller than its body.	16 ounces to 5 gallons †

3. **Required Codes:**

<u>Resin Type</u>	<u>Code Number</u> †	<u>Code Letters</u> †
Polyethylene Terephthalate	1	PETE
High Density Polyethylene	2	HDPE
Vinyl	3	V
Low Density Polyethylene	4	LDPE
Polypropylene	5	PP
Polystyrene	6	PS
Other	7	OTHER

- A. Base cups and labels: Containers with base cups or labels of different material shall be coded by their primary basic material. †
- B. Multilayer: Include as "7-OTHER."

4. **Required Symbol:** RIS; Size not specified. †

† Denotes requirements that are consistent with the SPI Voluntary Code

PLASTIC CONTAINER CODING SUMMARY

5. **Type and Location of Code:** Molded on the bottom of the bottle or container.

6. **Penalties:** None provided.

7. **Additional Information:**

Department of Health  
Division of Waste Management  
4210 East 11th Avenue  
Denver, Colorado 80220  
(303) 320-8333  
[Not yet officially responsible for  
implementation]

8. **Attachment:** COLO. REV. STAT. §25-17-102, May 17, 1989

1989

# An Act

HOUSE BILL NO. 1300.

BY REPRESENTATIVES Tucker, Bond, DeHerrera, Fish, P. Hernandez, Johnson, Jones, Kerns, Killian, Knox, Kopel, Masson, Pierson, Romero, Ruddick, Rupert, Schauer, Shoemaker, Tanner, Webb, K. Williams, S. Williams, and Wright; also SENATORS Considine, Allison, DeNier, Hopper, Hume, Mendez, Norton, Owens, Pascoe, Peterson, Rizzuto, Schaffer, Schroeder, Strickland, Tebedo, Traylor, Wattenberg, Wells, Wham, and Winkler.

CONCERNING THE RECYCLING OF PLASTIC PRODUCTS.

Be it enacted by the General Assembly of the State of Colorado:

SECTION 1. Title 25, Colorado Revised Statutes, 1982 Repl. Vol., as amended, is amended BY THE ADDITION OF A NEW ARTICLE to read:

## ARTICLE 17 Recycling of Plastics

25-17-101. Legislative declaration. The general assembly hereby finds and declares that the recycling of plastic materials is a matter of statewide concern and that such recycling should be promoted in cooperation with units of local government in light of its economic and environmental benefits. The general assembly further finds that the recycling of plastic products will decrease the amount of plastic which is disposed of in landfills and will also spur economic development in the recycling industry in Colorado. It is the intent of the general assembly in adopting this act to encourage the development of the recycling industry and the development of markets for recycled plastic materials.

25-17-102. Definitions. As used in this article, unless the context otherwise requires:

(1) "Label" means one of the code labels described in section 25-17-103 which is molded into the bottom of a plastic container.

(2) "Plastic" means any material made of polymeric organic compounds and additives that can be shaped by flow.

(3) "Plastic bottle" means a plastic container that has a neck that is smaller than the body of the container, accepts a screw-type, snap-cap, or other closure, and has a capacity of sixteen fluid ounces or more but less than five gallons.

(4) "Rigid plastic container" means any formed or molded container other than a bottle, intended for single use, composed predominantly of plastic resin, and having a relatively inflexible finite shape or form with a capacity of eight ounces or more but less than five gallons.

25-17-103. Labeling and coding. (1) On or after July 1, 1992, no person shall distribute, sell, or offer for sale in this state any plastic bottle or rigid plastic container manufactured on or after July 1, 1992, unless the product is labeled with a code indicating the plastic resin used to produce the bottle or container. Plastic bottles or rigid plastic containers with labels and basecaps of a different material shall be coded by their basic material. Such code shall consist of a number placed within a triangle of arrows and letters placed below the triangle of arrows. The triangle shall be equilateral, formed by three arrows with the apex of each point of the triangle at the midpoint of each arrow, rounded with a short radius. The arrowhead of each arrow shall be at the midpoint of each side of the arrow. The triangle, formed by the three arrows curved at their midpoints, shall depict a clockwise path around the code number. The numbers and letters used shall be as follows: 1-PETE (polyethylene terephthalate), 2-HDPE (high density polyethylene), 3-V (vinyl), 4-LDPE (low density polyethylene), 5-PP (polypropylene), 6-PS (polystyrene), 7-OTHER (includes multi-layer).

25-17-104. Local government preemption. No unit of local government shall require or prohibit the use or sale of specific types of plastic materials or products.

25-17-105. Pilot program - recycled plastic - rules. (1) The executive director of the department of local affairs may establish a pilot program for the purpose of encouraging private industry to engage in the research and development of new technologies for recycling plastics. The executive director of the department of local affairs may cooperate with any other entity of state government, including institutions of higher education, in developing the pilot program.

(2) The executive director of the department of local affairs may make grants or loans to private industry for the research and development authorized by subsection (1) of this section. Said grants and loans shall be made only to private industries for location or expansion in Colorado.

(3) The executive director of the department of local affairs is hereby authorized to accept any grants or loans from any public or private source for the purpose of encouraging plastics recycling. None of such moneys shall be used for overhead or administrative costs of the department.

25-17-106. Repeal of article. This article is repealed, effective July 1, 1994.

SECTION 2. Title 8, Colorado Revised Statutes, 1986 Repl. Vol., as amended, is amended BY THE ADDITION OF A NEW ARTICLE to read:

#### ARTICLE 19.5

##### Bid Preference - Recycled Plastic Products

###### 8-19.5-101. Bid preference - recycled plastic products.

(1) When a contract is to be awarded in a public project, a bidder who has used recycled plastics in the manufacture of the commodity or supplies described in the bid shall be allowed a preference of up to five percent for finished products which contain no less than ten percent recycled plastics.

(2) If it is determined by the officer responsible for awarding a bid that compliance with this section may cause denial of federal moneys which would otherwise be available or would otherwise be inconsistent with requirements of federal law, this section shall be suspended, but only to the extent necessary to prevent denial of the moneys or to eliminate the inconsistency with federal requirements.

(3) For purposes of this section, "public project" means any publicly funded contract entered into by a governmental body of the executive branch of this state which is subject to the "Procurement Code", articles 101 to 112 of title 24, C.R.S.

SECTION 3. Article 22 of title 39, Colorado Revised Statutes, 1982 Repl. Vol., as amended, is amended BY THE ADDITION OF A NEW SECTION to read:

39-22-114.5. Tax credit for investment in technologies for recycling plastics. (1) There shall be allowed to each resident individual, as a credit against the income taxes imposed by this article, a plastic recycling credit equal to

twenty percent of net expenditures to third parties for rent, wages, supplies, consumable tools, equipment, test inventory, and utilities up to ten thousand dollars made by the taxpayer for new plastic recycling technology in Colorado, with a maximum credit of two thousand dollars. The tax credit allowed in this section shall be applicable only to income related to the expenditures described in this subsection (1).

(2) If the credit allowed under this section exceeds the income taxes otherwise due on the claimant's income, the amount of the credit not used as an offset against income taxes may be carried forward as a tax credit against subsequent years' income tax liability for a period not exceeding five years and shall be applied first to the earliest years possible.

(3) Any form filed with the department of revenue for the purpose of claiming the credit allowed by this section shall be accompanied by copies of any receipts, bills, or other documentation of the qualified expenditures claimed for the purpose of receiving such credit.

SECTION 4. Part 3 of article 22 of title 39, Colorado Revised Statutes, 1982 Repl. Vol., as amended, is amended BY THE ADDITION OF A NEW SECTION to read:

39-22-309. Tax credit for investment in technologies for recycling plastics. (1) There shall be allowed to each domestic corporation and foreign corporation, as a credit against the income taxes imposed by this part 3, a plastic recycling credit equal to twenty percent of net expenditures to third parties for rent, wages, supplies, consumable tools, equipment, test inventory, and utilities up to ten thousand dollars made by the taxpayer for new plastic recycling technology in Colorado, with a maximum credit of two thousand dollars. The tax credit allowed in this section shall be applicable only to income related to the expenditures described in this subsection (1).

(2) If the credit allowed under this section exceeds the income taxes otherwise due on the claimant's income, the amount of the credit not used as an offset against income taxes may be carried forward as a tax credit against subsequent years' income tax liability for a period not exceeding five years and shall be applied first to the earliest years possible.

(3) Any form filed with the department of revenue for the purpose of claiming the credit allowed by this section shall be accompanied by copies of any receipts, bills, or other documentation of the qualified expenditures claimed for the purpose of receiving such credit.





SECTION 5. No appropriation. The general assembly has determined that this act can be implemented within existing appropriations, and therefore no separate appropriation of state moneys is necessary to carry out the purposes of this act.

SECTION 6. Effective date - applicability. This act shall take effect July 1, 1989, and section 4 of this act shall apply to tax years commencing on or after January 1, 1989 and until January 1, 1994.

SECTION 7. Safety clause. The general assembly hereby finds, determines, and declares that this act is necessary for the immediate preservation of the public peace, health, and safety.

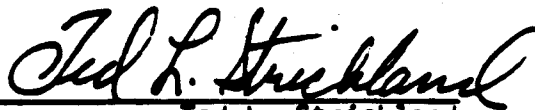
  
\_\_\_\_\_  
Carl B. Bledsoe  
SPEAKER OF THE HOUSE  
OF REPRESENTATIVES

  
\_\_\_\_\_  
Ted L. Strickland  
PRESIDENT OF  
THE SENATE

  
\_\_\_\_\_  
Lee C. Bahrych  
CHIEF CLERK OF THE HOUSE  
OF REPRESENTATIVES

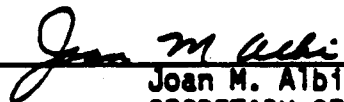
  
\_\_\_\_\_  
Joan M. Albi  
SECRETARY OF  
THE SENATE

APPROVED May 17, 1989 at 9:45 am

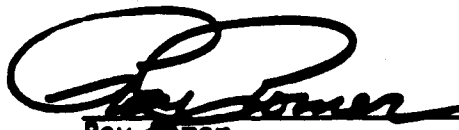
  
\_\_\_\_\_  
Roy Romer  
GOVERNOR OF THE STATE OF COLORADO

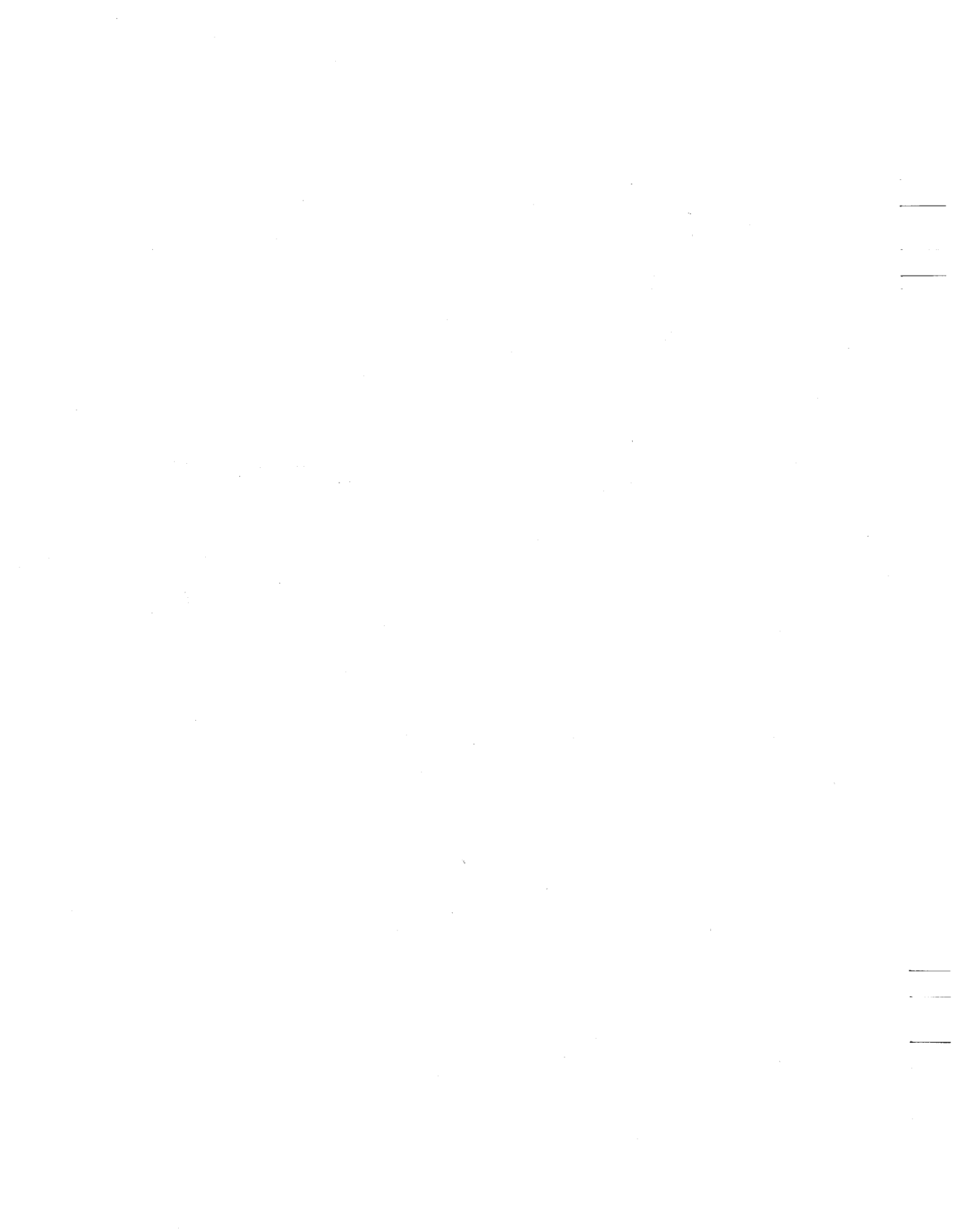

## HAWAII

1. **Compliance Date:** January 1, 1992
2. **Scope:** Containers manufactured, distributed, sold, or exposed for sale in Hawaii:

<u>Type</u>	<u>Size</u>
<p><u>Rigid Plastic Containers</u> -- Formed or molded container; intended for single use, composed predominantly of plastic resin, relatively inflexible, finite shape.</p>	8 ounces to 5 gallons †
<p><u>Plastic Bottles</u> -- Container with a neck smaller than its body; accepts a closure.</p>	16 ounces to 5 gallons †

3. **Required Codes:**

<u>Resin Type</u>	<u>Code Number</u> †	<u>Code Letters</u> †
Polyethylene Terephthalate	1	PETE
High Density Polyethylene	2	HDPE
Vinyl	3	V
Low Density Polyethylene	4	LDPE
Polypropylene	5	PP
Polystyrene	6	PS
Other	7	OTHER

A. Base cups and labels: No provision. †

B. Multilayer: No provision.

4. **Required Symbol:** RIS; size not specified. †

5. **Type and Location of Symbol:** Molded imprint or raised symbol on or near the bottom of a plastic product.

† Denotes requirements that are consistent with the SPI Voluntary Code

6. **Penalties:** None specified.

7. **Additional Information:**

Solid and Hazardous Waste Branch  
Office of Environmental Quality Control  
Department of Health  
465 S. King Street, Room 104  
Honolulu, Hawaii 96813  
(808) 543-8227

8. **Attachments:** 1990 Haw. Sess. Laws 318

† Denotes requirements that are consistent with the SPI Voluntary Code

SECTION 3. New statutory material is underscored.<sup>1</sup>

SECTION 4. This Act shall take effect upon its approval.

(Approved July 3, 1990.)

**Note**

1. Edited pursuant to HRS §23G-16.5.

**ACT 318**

H.B. NO. 1023

A Bill for an Act Relating to Environmental Quality.

*Be It Enacted by the Legislature of the State of Hawaii:*

SECTION 1. Chapter 342H, Hawaii Revised Statutes, is amended by adding a new part to be appropriately designated and to read as follows:

**"PART . PLASTIC CONTAINER CODING**

§342H- Definitions. As used in this chapter, unless the context otherwise requires:

"Label" means a molded imprint or raised symbol on or near the bottom of a plastic product.

"Plastic" means any material made of polymeric organic compounds and additives that can be shaped by flow.

"Plastic bottle" means a plastic container intended for single use that has a neck that is smaller than the body of the container, accepts a screw-type, snap cap, or other closure and has a capacity of sixteen fluid ounces or more, but less than five gallons.

"Rigid plastic container" means any formed or molded container, other than a bottle, intended for single use, composed predominantly of plastic resin, and having a relatively inflexible finite shape or form with a capacity of eight ounces or more, but less than five gallons.

§342H- Prohibition. On or after January 1, 1992, no person shall manufacture, distribute, sell, or expose for sale in this State any plastic bottle or rigid plastic container unless the product has a label indicating the plastic resin used to produce the plastic bottle or rigid plastic container. The label shall consist of a number placed within a triangle of arrows and letters placed below the triangle: The triangle shall be equilateral, formed by three arrows curved at their midpoints and depicting a clockwise path around the code number. The numbers and letters used shall be as follows:

- (1) For polyethylene terephthalate, the letters "PETE" and the number 1;
- (2) For high density polyethylene, the letters "HDPE" and the number 2;
- (3) For vinyl, the letter "V" and the number 3;
- (4) For low density polyethylene, the letters "LDPE" and the number 4;
- (5) For polypropylene, the letters "PP" and the number 5;
- (6) For polystyrene, the letters "PS" and the number 6; and
- (7) For any other, the letters "OTHER" and the number 7."

989

**ACT 319**

**SECTION 2.** This Act shall take effect upon its approval.

(Approved July 3, 1990.)

**ACT 319**

**H.B. NO. 3299**

**A Bill for an Act Relating to Energy Conservation.**

*Be It Enacted by the Legislature of the State of Hawaii:*

**SECTION 1.** The legislature recognizes the need to promote and support energy conservation and renewable energy resources in the State of Hawaii. The legislature finds, however, that the State's dependency on imported fossil fuel remains unabated, even in the face of the emergence of cost-effective and energy-saving technologies. Accordingly, the use of commercially available energy conservation systems, the adoption of energy-saving measures, and the development of demand-side management programs should be promoted to encourage the consumer's efficient use of energy resources.

Solar water heating systems and heat pumps are off-the-shelf, commercially available energy conservation systems that give every resident the opportunity to use an abundant renewable energy resource—the sun. Additionally, ice storage systems are designed to shift the consumption of energy to off-peak periods.

Although solar energy systems and heat pumps for water heating can play a major role in energy conservation, the current low price of imported oil has adversely affected the competitive viability of such devices. Further, the continued prudent use of energy by devices, such as ice storage systems, should be encouraged. As such, the legislature finds that incentives in the form of higher state tax credits are needed to ensure that progress will continue toward the State's goals of reducing its dependence on imported oil and using energy prudently. One of the purposes of this Act then, is to provide for a tax credit increase for the installation of ice storage systems and of solar water heating systems and to clarify the tax credit for heat pumps in new and existing buildings.

Recognizing our dependency on imported oil and our fragile and vulnerable economic foundation, the Hawaii state plan promotes the prudent use of power and fuel supplies through conservation measures. Consumer demand for energy must be considered an important variable that can be influenced by public utility actions. Demand-side management is the planning and implementation of utility actions to influence consumer use of energy to affect the utility system's demand characteristics. Acknowledging the importance of demand-side management, this Act also amends the state policy relating to the use of energy to include demand-side management programs as a conservation measure.

**SECTION 2.** Section 226-18(c), Hawaii Revised Statutes, is amended by amending subsection (c) to read as follows:

“(c) To further achieve the energy objectives, it shall be the policy of this State to:

- (1) Support research and development as well as promote the use of renewable energy sources[.]
- (2) Ensure a sufficient supply of energy to enable power systems to support the demands of growth[.]

**990**

## OKLAHOMA

1. **Compliance Date:** July 1, 1991
2. **Scope:** Plastic containers distributed, received for sale, or offered for sale in Oklahoma:

<u>Type</u>	<u>Size</u>
<p><u>Rigid Plastic Containers</u> -- Formed or molded container, intended for single use, composed predominantly of plastic resin, relatively inflexible, finite shape.</p>	8 ounces to 5 gallons †
<p><u>Plastic Bottles</u> -- Container that has a neck smaller than its body and accepts a screw-type, snap-cap, or other closure.</p>	16 ounces to 5 gallons †

3. **Required Codes:**

<u>Resin Type</u>	<u>Code Number</u> †	<u>Code Letters</u> †
Polyethylene Terephthalate	1	PETE
High Density Polyethylene	2	HDPE
Vinyl	3	V
Low Density Polyethylene	4	LDPE
Polypropylene	5	PP
Polystyrene	6	PS
Other	7	OTHER

A. Base cups and labels: No provision.

B. Multilayer: No provision.

4. **Required Symbol:** RIS; size not specified.
5. **Type and Location of Symbol:** Molded, imprinted, or raised symbol on or near the bottom of the container.

† Denotes requirements that are consistent with the SPI Voluntary Code

6. **Penalties:** Any person convicted of violating the law shall be guilty of a misdemeanor.

7. **Additional Information:**

Ms. Kelly Dixon  
Solid Waste Management Service  
Oklahoma Department of Health  
1000 NE 10th Street  
Oklahoma City, Oklahoma 73152  
(405) 271-7159

8. **Attachments:** Enrolled House Bill No. 1841

† Denotes requirements that are consistent with the SPI Voluntary Code



# An Act

ENROLLED HOUSE  
BILL NO. 1841

BY: LEIST, CAMPBELL, JOHNSON  
(Rob), WILLIAMS (Danny),  
ADAIR, GURLEY, APPLE,  
FERGUSON, COFFEE, GLENN,  
and HAMILTON (Jeff) of  
the HOUSE

and

SHURDEN, WILLIAMS (Don)  
and WILLIAMS (Penny) of  
the SENATE

AN ACT RELATING TO PUBLIC HEALTH AND SAFETY;  
DEFINING TERMS; REQUIRING ALL PLASTIC CONTAINERS  
SOLD IN OKLAHOMA TO HAVE A MOLDED LABEL INDICATING  
THE PREDOMINANT PLASTIC RESIN USED TO PRODUCE THE  
PRODUCT; PROHIBITING CERTAIN ACTIONS; PROVIDING  
SPECIFICATIONS; REQUIRING MAINTENANCE OF CERTAIN  
LISTS; PROVIDING PENALTIES; PROVIDING FOR  
CODIFICATION; AND PROVIDING AN EFFECTIVE DATE.

BE IT ENACTED BY THE PEOPLE OF THE STATE OF OKLAHOMA:

SECTION 1. NEW LAW A new section of law to be codified in the Oklahoma Statutes as Section 3001.1 of Title 63, unless there is created a duplication in numbering, reads as follows:

For the purposes of this act:

1. "Department" means the State Department of Health;
2. "Label" means a molded, imprinted or raised symbol on or near the bottom of a plastic container or bottle;
3. "Person" means an individual, sole proprietor, partnership, association, corporation or other legal entity;
4. "Plastic" means any material made of polymeric organic compounds and additives that can be shaped by flow;
5. "Plastic bottle" means a plastic container intended for single use that has a neck that is smaller than the body of the container, accepts a screw-type, snap cap or other closure and has a capacity of sixteen (16) fluid ounces or more, but less than five (5) gallons;
6. "Rigid plastic container" means any formed or molded container, other than a bottle, intended for single use, composed predominantly of plastic resin, and having a relatively inflexible finite shape or form with a capacity of eight (8) ounces or more but less than five (5) gallons.

SECTION 2. NEW LAW A new section of law to be codified in the Oklahoma Statutes as Section 3001.2 of Title 63, unless there is created a duplication in numbering, reads as follows:

A. On or after July 1, 1991, no person shall distribute, receive for sale or offer for sale in this state any plastic bottle or rigid

plastic container unless such container is labeled with a code identifying the appropriate resin type used to produce the structure of the container.

B. The code shall consist of a number placed within three triangulated arrows and letters placed below the triangle of arrows. The triangulated arrows shall be equilateral, formed by three arrows with the apex of each point of the triangle at the midpoint of each arrow, rounded with a short radius. The pointer (arrowhead) of each arrow shall be at the midpoint of each side of the triangle with a short gap separating the pointer from the base of the adjacent arrow. The triangle, formed by the three arrows curved at their midpoints shall depict a clockwise path around the code number. The numbers and letters used shall be as follows:

1. = PETE (polyethylene terephthalate);
2. = HDPE (high density polyethylene);
3. = V (vinyl);
4. = LDPE (low density polyethylene);
5. = PP (polypropylene);
6. = PS (polystyrene);
7. = OTHER.

C. The Department shall maintain a list of the label code provided in subsection B of this section and shall provide a copy of that list to any person upon request.

D. The state Board of Health may by regulation adopt a different plastic container labeling system than the one specified in this statute if there is any change in the nationally recognized standard codified herein.

E. Any person convicted of violating the provisions of this act shall be guilty of a misdemeanor.

SECTION 3. This act shall become effective September 1, 1990.

Passed the House of Representatives the 19th day of April, 1990.

Alan Jensen  
Speaker of the House of  
Representatives

Passed the Senate the 17th day of April, 1990.

Pat Williams  
President of the Senate  
Pro Tempore

OFFICE OF THE GOVERNOR

Received by the Governor this 23<sup>rd</sup>  
day of April, 1990,  
at 3:00, o'clock P. M.

By: Robyn Hamm Roberts

Approved by the Governor of the State of Oklahoma the 24<sup>th</sup> day of  
April, 1990, at 2:10, o'clock P. M.

Henry Beeman  
Governor of the State of Oklahoma

OFFICE OF THE SECRETARY OF STATE

Received by the Secretary of State this 24<sup>th</sup>  
day of April, 1990,  
at 2:50, o'clock P. M.

Harold D. Atkins  
By: \_\_\_\_\_



## TEXAS

1. **Compliance Date:** July 1, 1991
2. **Scope:** Plastic products that can be shaped by flow manufactured or distributed in the state:

<u>Type</u>	<u>Size</u>
<u>Plastic Bottles</u> -- Container with neck smaller than its body and accepts a closure.	16 ounces to 5 gallons †
<u>Rigid Plastic Containers</u> -- Other than bottle; intended for single use; relatively inflexible finite shape.	8 ounces to 5 gallons †

3. **Required Codes:**

<u>Resin Type</u>	<u>Code Number</u> †	<u>Code Letters</u> †
Polyethylene Terephthalate	1	PETE
High Density Polyethylene	2	HDPE
Vinyl	3	V
Low Density Polyethylene	4	LDPE
Polypropylene	5	PP
Polystyrene	6	PS
Other	7	OTHER

A. Base cups and labels: A plastic bottle or rigid plastic container with a base cup or other component of a material different from the basic material used in making the bottle or container shall bear the symbol indicating its basic material. †

B. Multilayer: Include as "7-OTHER."

4. **Required Symbol:** RIS; Size not specified. †
5. **Type and Location of Code:** Molded into or imprinted on the bottom or near the bottom of the bottle or container.

† Denotes requirements that are consistent with the SPI Voluntary Code

6. **Penalties:** Civil penalty not more than \$500 for each violation of the Act.

7. **Additional Information:**

Mr. Hector Mendieta, P.E.  
Director, Division of  
Solid Waste Management  
Texas Department of Health  
1100 West 49th St.  
Austin, Texas 78756-3199  
Mr. Glendon Eppler: (512) 458-7271

8. **Attachment:** 1989 Tex. Sess. Law Serv. ch 36 §2,  
April 26, 1989

† Denotes requirements that are consistent with the SPI Voluntary Code

SECTION 2. The importance of this legislation and the crowded condition of the calendars in both houses create an emergency and an imperative public necessity that the constitutional rule requiring bills to be read on three several days in each house be suspended, and this rule is hereby suspended, and that this Act take effect and be in force from and after its passage, and it is so enacted.

Passed the Senate on February 21, 1989, by the following vote: Yeas 31, Nays 0; passed the House on April 13, 1989, by a non-record vote.

Approved April 26, 1989.

Effective 90 days after date of adjournment.

---

CHAPTER 36

S.B. No. 444

AN ACT

relating to coding of certain plastic containers to facilitate recycling; providing a civil penalty.

*Be it enacted by the Legislature of the State of Texas:*

SECTION 1. DEFINITIONS. In this Act:

- (1) "Department" means the Texas Department of Health.
- (2) "Plastic" means a material made of polymeric organic compounds and additives that can be shaped by flow.
- (3) "Plastic bottle" means a plastic container that:
  - (A) has a neck smaller than the body of the container;
  - (B) is designed for a screw-top, snap cap, or other closure; and
  - (C) has a capacity of not less than 16 fluid ounces or more than five gallons.
- (4) "Rigid plastic container" means a formed or molded container intended for single use, composed predominantly of plastic resin, that has a relatively inflexible finite shape or form with a capacity of not less than eight ounces or more than five gallons. This term does not include a plastic bottle.

SECTION 2. SYMBOLS FOR CERTAIN PLASTIC CONTAINERS. (a) A person may not manufacture or distribute a plastic bottle or rigid plastic container unless the appropriate symbol indicating the plastic resin used to produce the bottle or container is molded into or imprinted on the bottom or near the bottom of the bottle or container.

(b) A plastic bottle or rigid plastic container with a base cup or other component of a material different from the basic material used in making the bottle or container shall bear the symbol indicating its basic material.

(c) The symbols used under this section must consist of a number placed within a triangle of arrows and of letters placed below the triangle of arrows. The triangle must be equilateral, formed by three arrows with the apex of each point of the triangle at the midpoint of each arrow, rounded with a short radius. The arrowhead of each arrow must be at the midpoint of each side of the triangle with a short gap separating the arrowhead from the base of the adjacent arrow. The triangle formed by the arrows must depict a clockwise path around the number.

(d) The numbers, letters of the symbols, and the plastic resins represented by the symbols are:

- (1) 1 and PETE, representing polyethylene terephthalate;
- (2) 2 and HDPE, representing high density polyethylene;
- (3) 3 and V, representing vinyl;
- (4) 4 and LDPE, representing low density polyethylene;
- (5) 5 and PP, representing polypropylene;

- (6) 6 and PS, representing polystyrene; and
- (7) 7 and OTHER, representing all other resins, including layered plastics of a combination of materials.
- (e) The department shall:
  - (1) maintain a list of the symbols; and
  - (2) provide a copy of that list to any person on request.

**SECTION 3. PENALTY.** (a) A person who violates Subsection (a) or (b) of Section 2 of this Act is subject to a civil penalty of not more than \$500 for each act of violation.

(b) If it appears that a person has violated or is violating Section 2 of this Act, the attorney general or a district attorney, criminal district attorney, or county attorney shall institute and conduct a suit in the name of the State of Texas to recover the civil penalty imposed under Subsection (a) of this section.

(c) A civil penalty recovered under this section shall be deposited:

- (1) in the state treasury if the attorney general brings the suit; or
- (2) in the general fund of the county in which the violation occurred if a district attorney, criminal district attorney, or county attorney brings the suit.

**SECTION 4. EFFECTIVE DATE.** This Act takes effect September 1, 1989, and applies to plastic bottles and rigid plastic containers that are manufactured or distributed on or after July 1, 1991.

**SECTION 5. EMERGENCY.** The importance of this legislation and the crowded condition of the calendars in both houses create an emergency and an imperative public necessity that the constitutional rule requiring bills to be read on three several days in each house be suspended, and this rule is hereby suspended.

Passed the Senate on March 30, 1989, by the following vote: Yeas 30, Nays 0; passed the House on April 17, 1989, by a non-record vote.

Approved April 26, 1989.

Effective Sept. 1, 1989.

---

**CHAPTER 37**

**S.B. No. 453**

**AN ACT**

relating to use of compensatory time by fire fighters and police officers in certain cities.

*Be it enacted by the Legislature of the State of Texas:*

**SECTION 1.** Chapter 142, Local Government Code, is amended by adding Section 142.0016 to read as follows:

**Sec. 142.0016. USE OF COMPENSATORY TIME BY MEMBERS OF FIRE AND POLICE DEPARTMENTS IN MUNICIPALITY WITH POPULATION OF MORE THAN 10,000.** (a) This section applies only in a municipality with a population of less than 1.5 million that is eligible to adopt civil service under Chapter 143.

(b) A fire fighter or police officer may, with the approval of the governing body of the municipality, accept instead of overtime pay compensatory time at a rate equal to 1-1/2 times the number of overtime hours.

(c) A fire fighter or police officer may use compensatory time only when both the fire fighter or police officer and the municipality agree the time may be used.

(d) A municipality may at any time pay a fire fighter or police officer for all or part of the person's accumulated compensatory time if both the fire fighter or police officer and the municipality agree the time may be paid.