

# COMMERCIAL PAYLOADS



# COLUMBIA SPORTSWEAR

Columbia Sportswear's new Omni-Heat Infinity reflective technology will be incorporated into Intuitive Machines' upcoming missions to the Moon. In laboratory simulations leading up to this launch, Intuitive Machines' researchers have determined that the gold metallic foil of Columbia's Omni-Heat Infinity will provide benefits toward insulating their lunar lander against the extreme temperatures on the Moon. In this first-of-its-kind partnership, Intuitive Machines is proud to collaborate with Columbia and its shared commitment to innovation, technology, and exploration.

"Inspired by the reflective technology used by NASA, our Omni-Heat Infinity technology has been tested in many challenging environments on Earth, but the Moon represents a first for us," said Joe Boyle, Columbia brand president. "We're looking forward to collaborating with Intuitive Machines on their upcoming mission as we continue to push our technology to new heights."

Columbia is the flagship brand of Portland, Oregon-based Columbia Sportswear Company, and has been creating innovative apparel, footwear, accessories and equipment for outdoor enthusiasts since 1938. Columbia has become a leading global brand by channeling the company's passion for the outdoors and innovative spirit into technologies and performance products that keep people warm, dry, cool and protected year-round. In addition to helping insulate the lunar lander against the harsh environments in space, Columbia is the apparel partner for Intuitive Machines and is keeping the team comfortable and looking sharp at their headquarters in Houston, Texas.

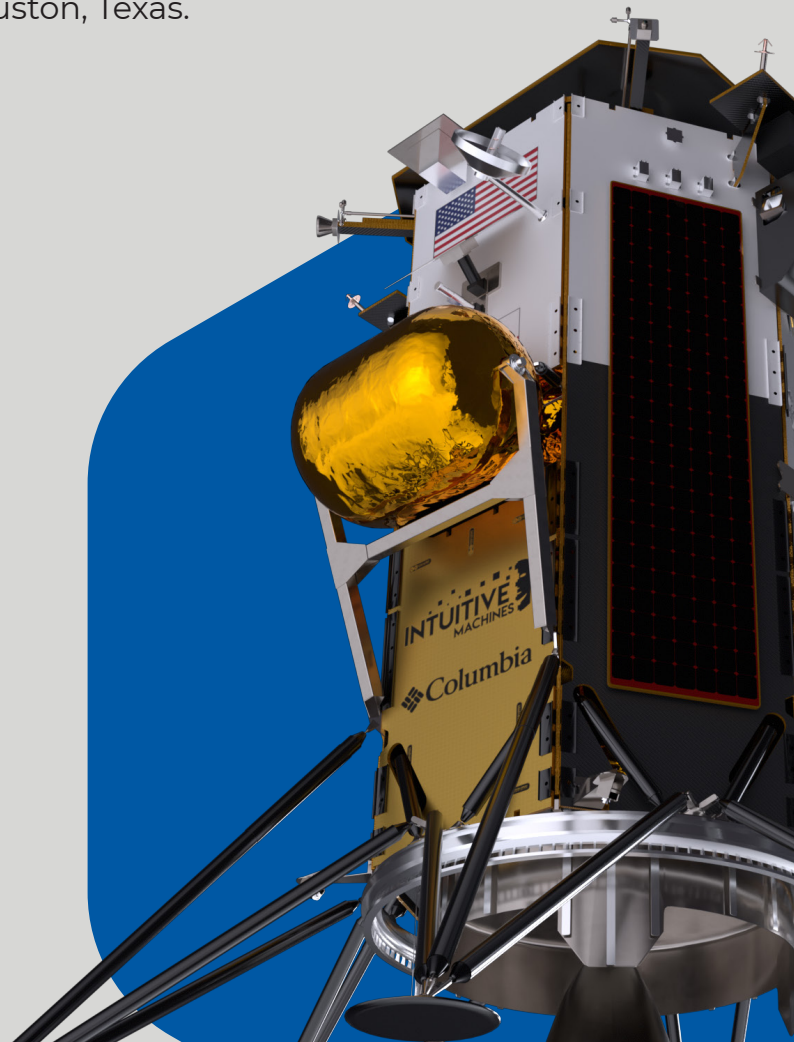

# EMBRY-RIDDLE EAGLECAM

Intuitive Machines' founder, Embry-Riddle alumnus Steve Altemus ('87), challenged his alma mater to engineer an out-of-this-world selfie when he visited the university in 2019. Students and faculty accepted Altemus' challenge and created EagleCam, a camera system to capture the world's the first-ever third-person picture of a spacecraft making an extraterrestrial landing. Additionally, the device will test an electrostatic dust-removal system, which could lead to future advances in spacesuit technology. EagleCam was created in the university's Space Technologies Laboratory, located in Embry-Riddle's Research Park.

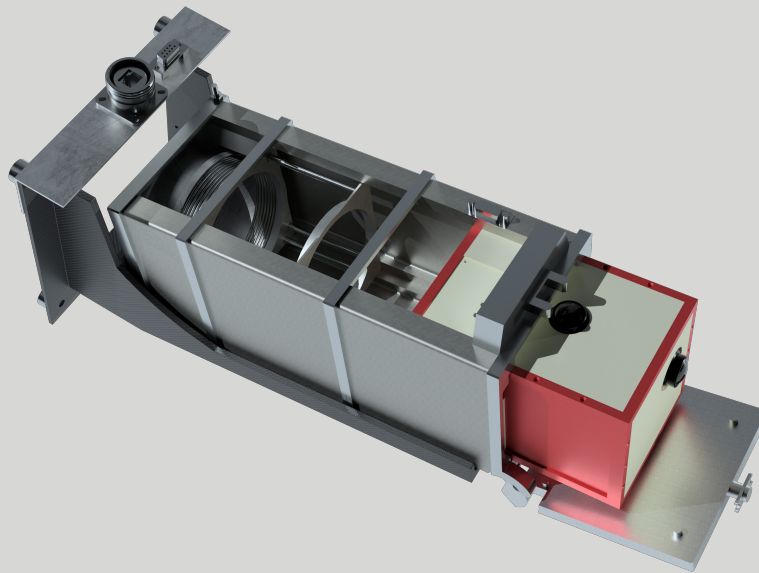

**EAGLECAM**  
CAMERA OPERATION DIAGRAM

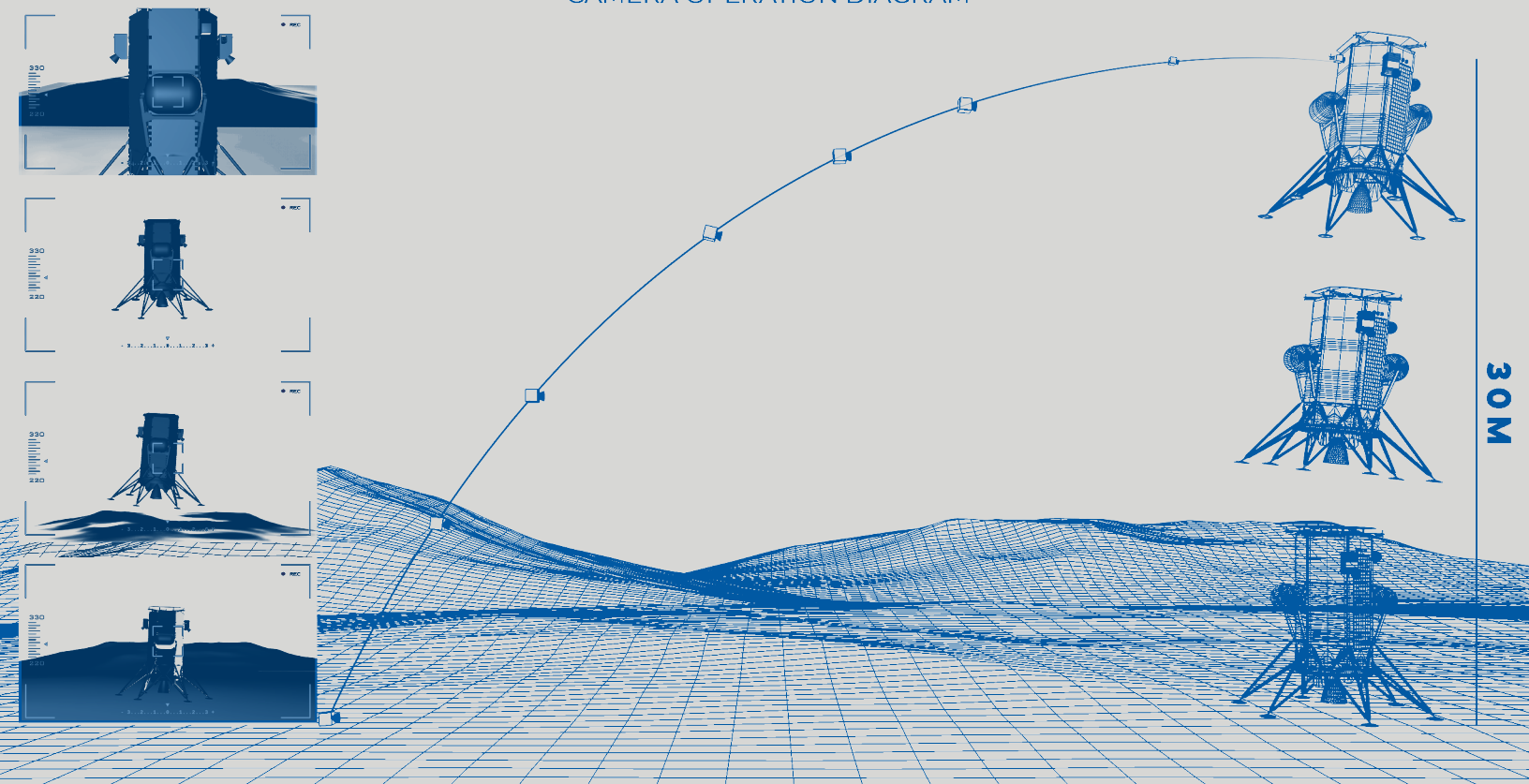

# JEFF KOONS ART CUBE

Each piece in Jeff Koons: Moon Phases comprises a unique digital work and corresponding physical sculptures, a group of which will make a lunar landing on an Intuitive Machines Nova-C Lunar Lander, to be launched on pad 39A at Kennedy Space Center in a fully autonomous mission.

Former NASA Astronaut and current Intuitive Machines Vice President, Jack Fischer says, “the Intuitive Machines team is passionate about this historic project. Koons’s sculptures, documented by the NFTs and housed in a transparent, thermally coated, sustainably built enclosed art cube, will be the first authorized artworks to be placed on the surface of the Moon, where they will remain in perpetuity.”

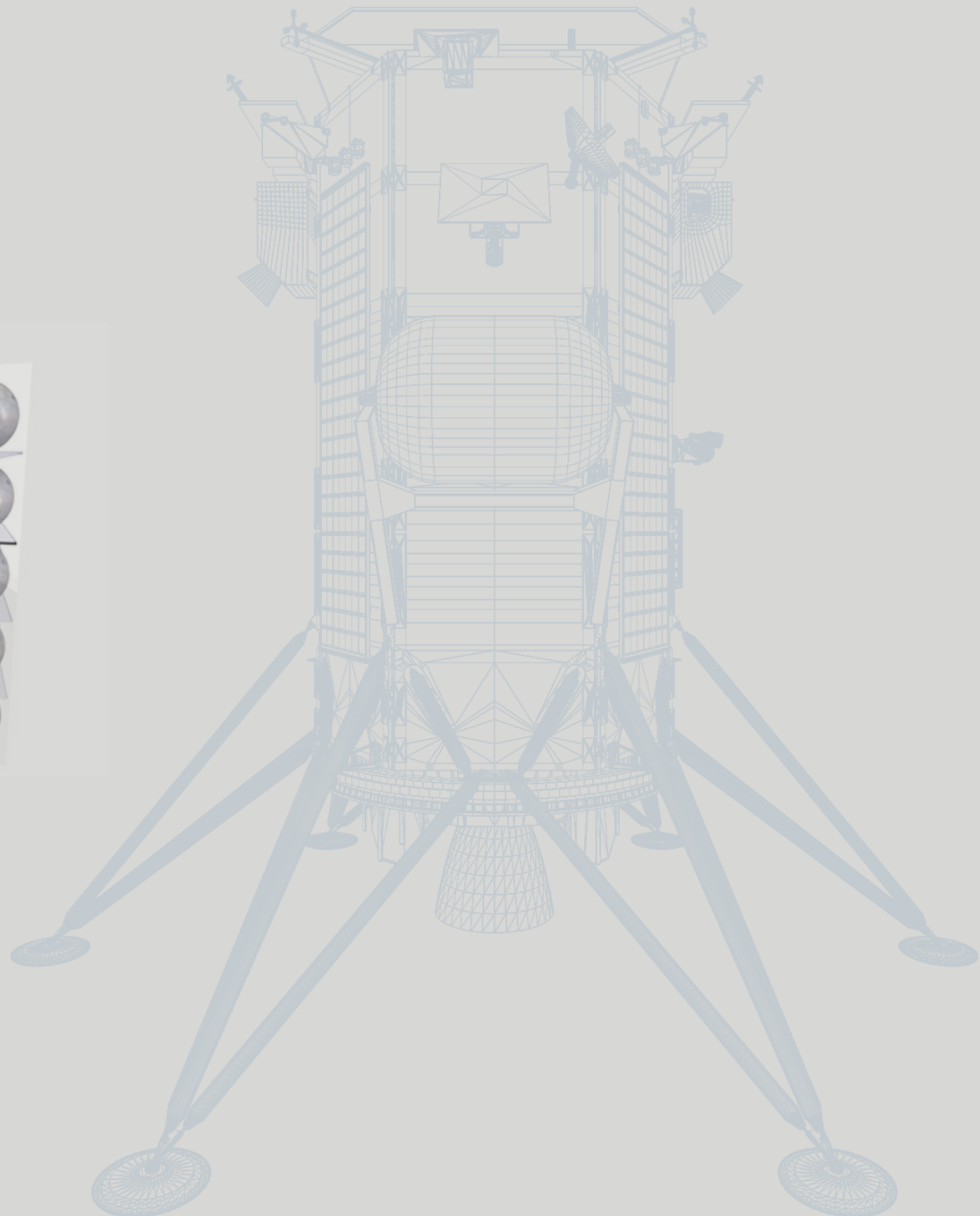
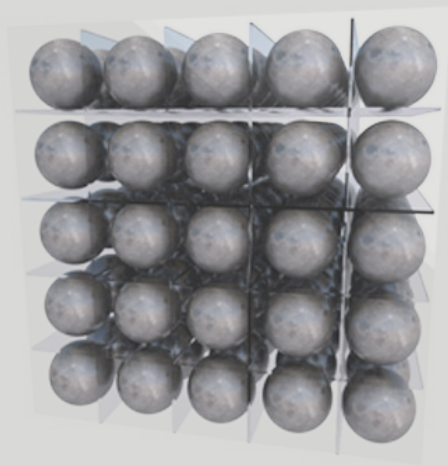

# INT'L LUNAR OBSERVATORY ASSOC.

ILO-X is a precursor to the ILOA Hawai'i flagship Moon South Pole Observatory ILO-1. The ~0.6 kg ILO-X instruments, built for ILOA by Toronto-based Canadensys Aerospace, includes a miniaturized dual-camera lunar imaging suite (one wide-field and one-narrow field).

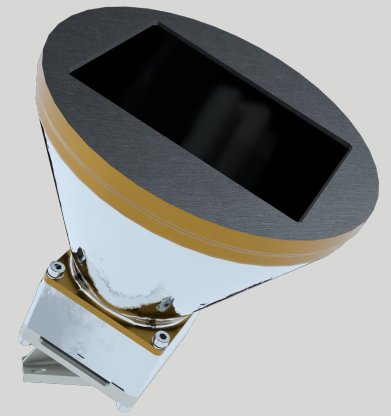

It will aim to capture some of the first images of the Milky Way Galaxy Center from the surface of the Moon, as well as performing other celestial / Earth / local lunar environment observations and exploration technology validations – including functionality and survivability in the lunar environment.

From March through May of 2022, ILOA Hawai'i invited all Hawai'i based classrooms to participate in a naming contest for the narrow-field ILO-X imager. This mission will be the first Hawai'i-based organization's cameras on the Moon. Hawai'i is a place that honors science, discovery and mindful exploration. Receiving a name for the ILO-X narrow-field camera from the next generation of scientists of Hawai'i is a great honor and celebration of the unique communities and knowledge that exists on the Hawaiian Islands of which ILOA calls home.

Carrying to the Moon Surface:

ILOA Moon Memorial: Names of Directors, Past Colleagues, Friends

37 images and artwork including Space Calendar first editions, ILOA Galaxy Map, ILO-1 Moon South Pole Astronomy Vision and International First Women on the Moon by Michael Carroll

Carrying to the Moon Surface and Broadcasting back to Earth:

2022 Space Calendar and Downrange to 10.3 Billion Years  
Space Calendar Lunar Broadcasting Advertisement

Looking toward the future, larger ILO-1 and ILO-2 observation and communications missions are under development, with follow-on launches planned NET 2024.

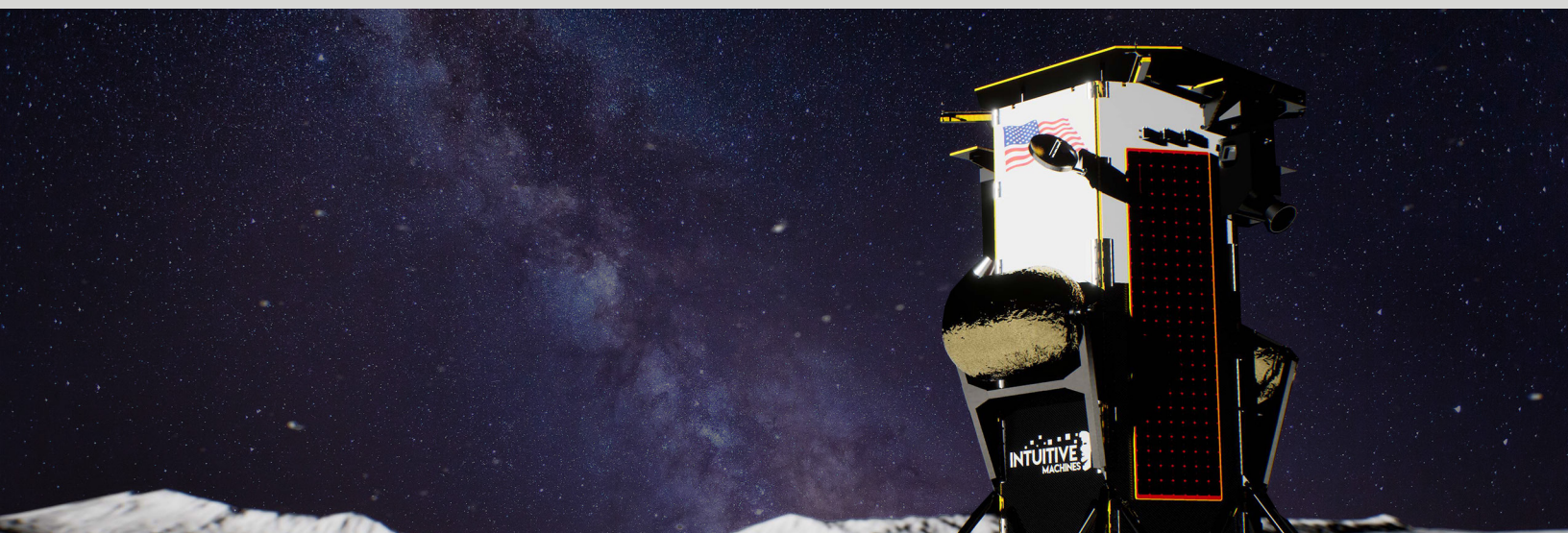

# LUNAPRISE

GLL Space's mission is to preserve the heart and soul of humanity through the gathering and archiving of stories into a single collection called, The Humanity Hall of Fame.

Each microfiche disk will carry messages called lunagrams. The messages use words and photos to tell a story to show future civilizations how we lived and loved.

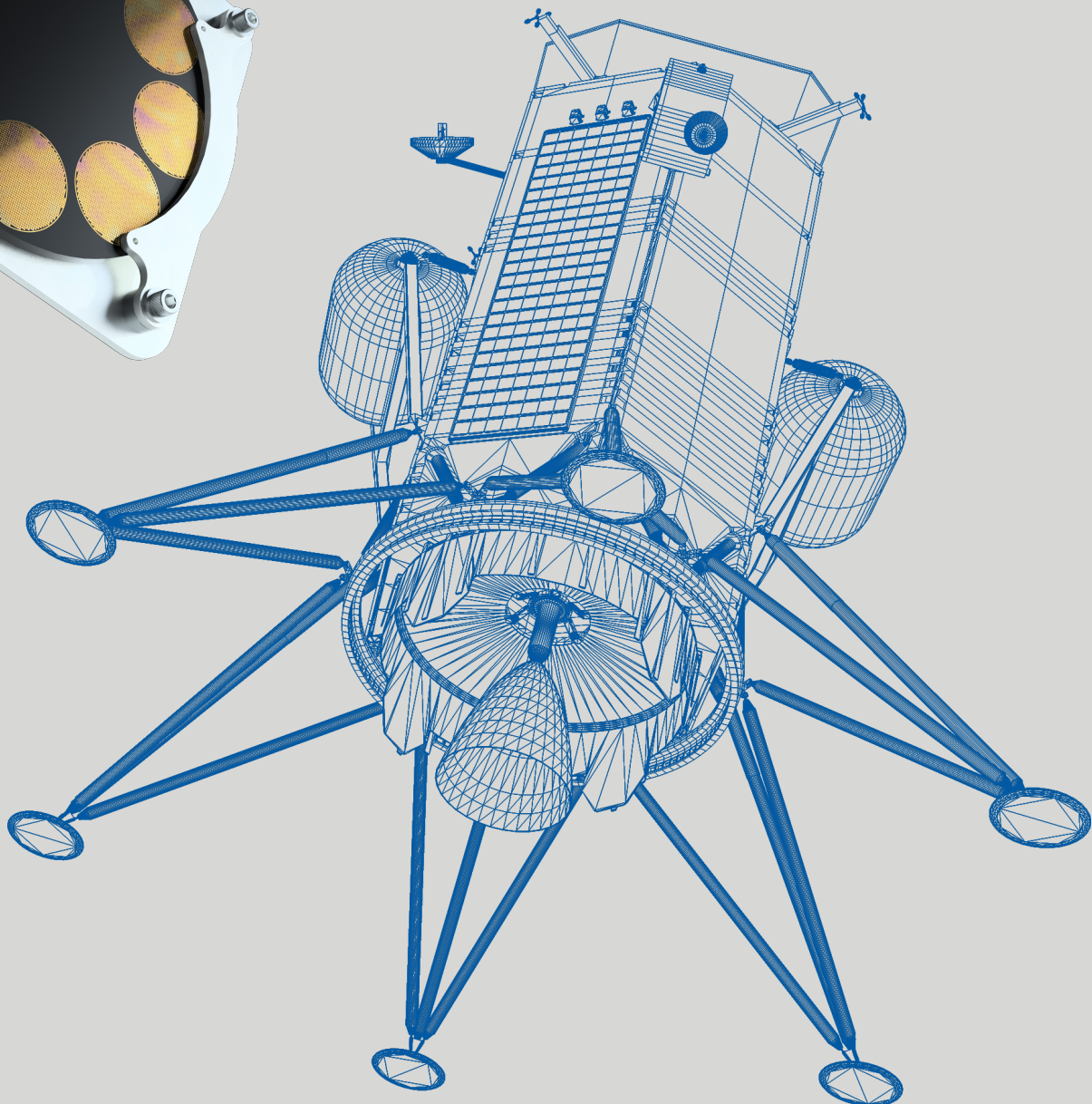
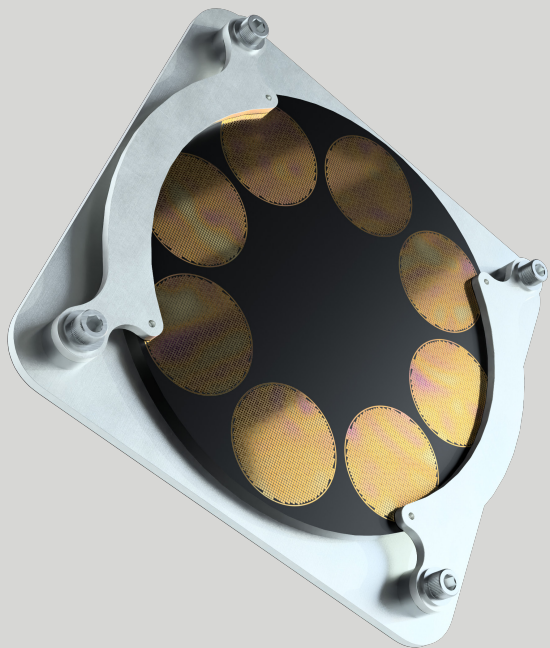

# LONESTAR

Lonestar Data Holdings Inc. is launching a series of data centers to the lunar surface and has contracted for its first two missions to the lunar surface and for the build of its first data services payload, the first data center to the Moon, starting with Intuitive Machines' IM-1.

The build of the first ever data center payload for Lonestar's proof-of-concept service has been contracted with Skycorp.

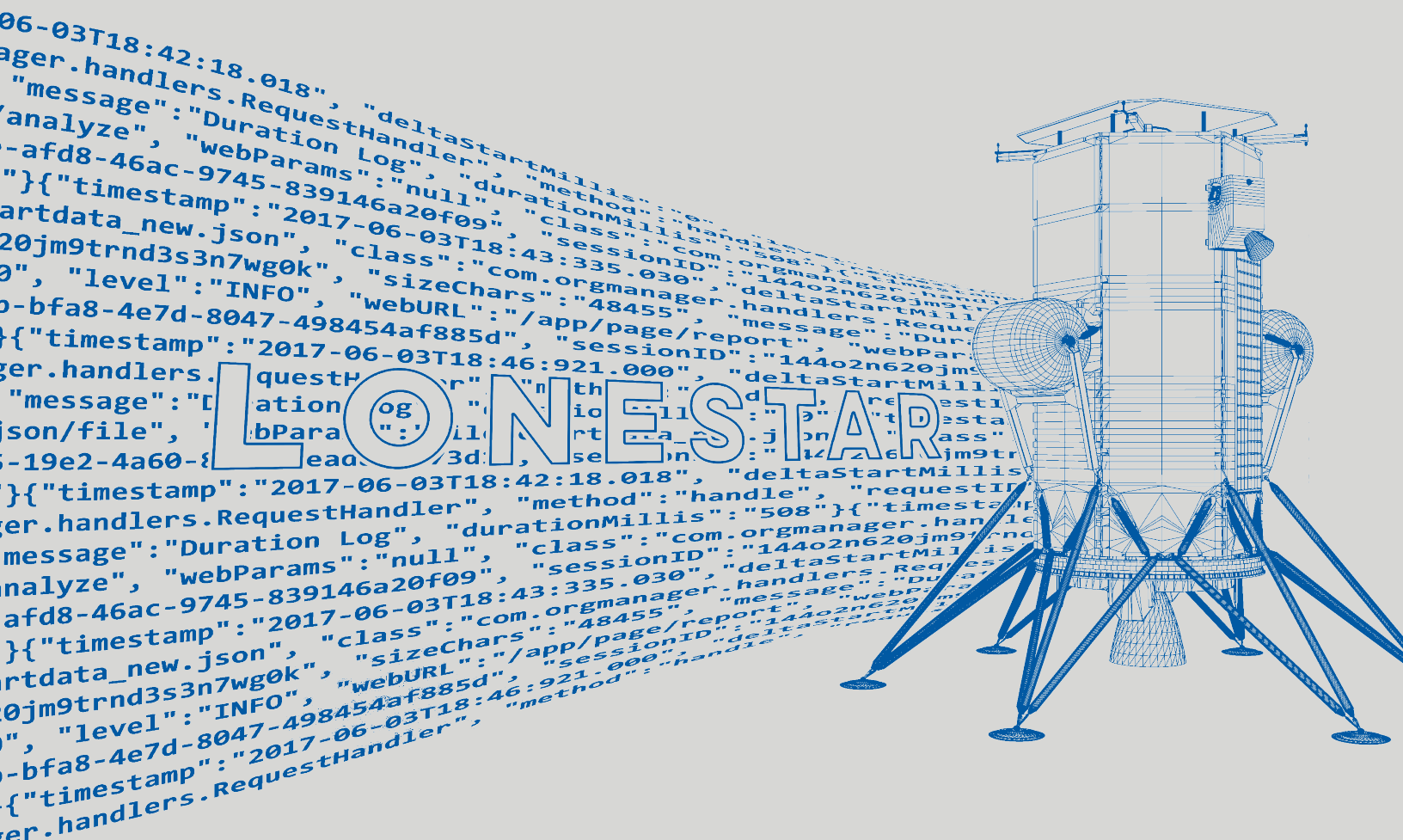

# NASA PAYLOADS

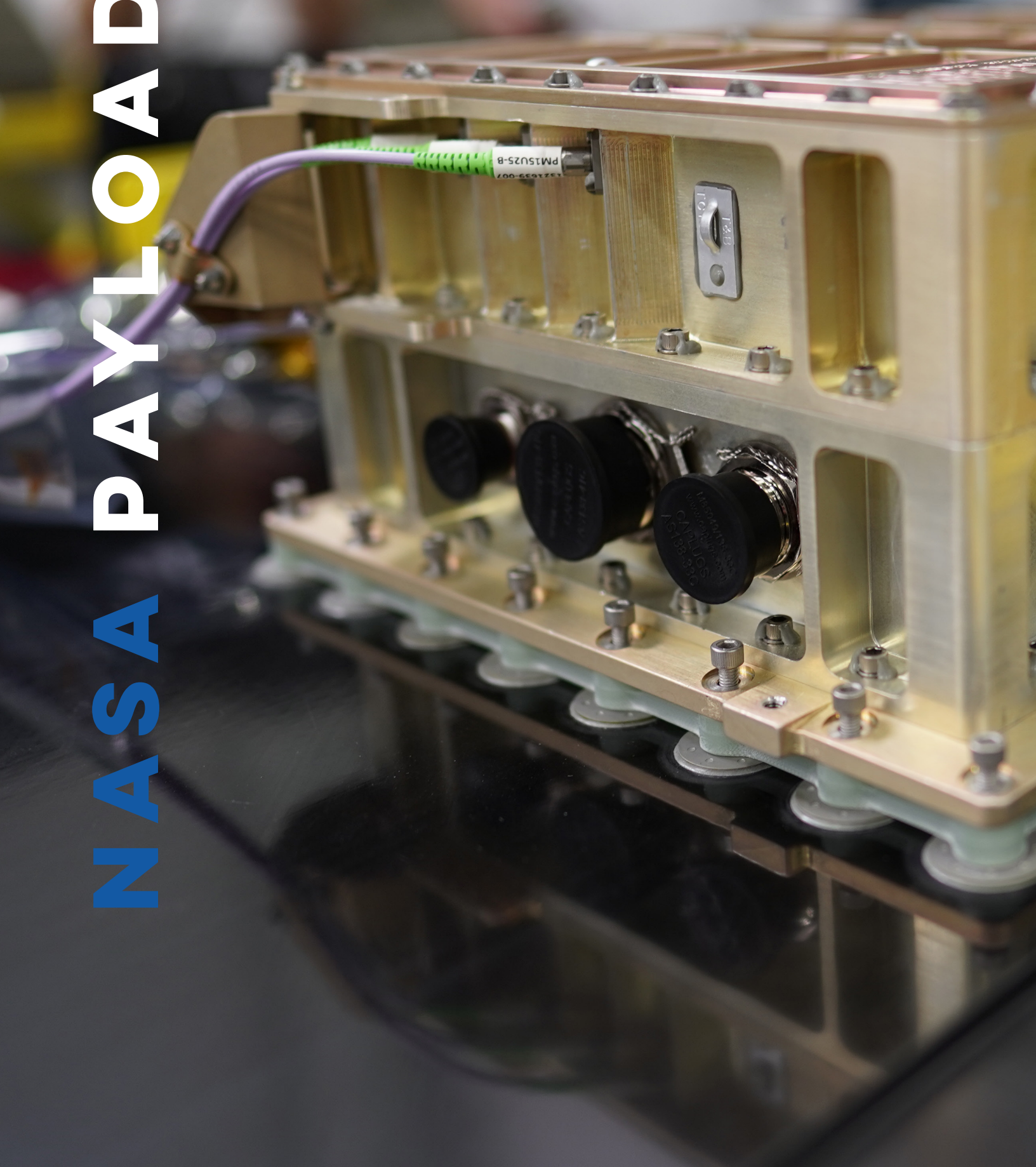



# ROLSSES

RADIO OBSERVATIONS OF THE LUNAR SURFACE PHOTOELECTRON SHEATH

**Lead Development Organization:** NASA Goddard Space Flight Center

**Payload Mass:** 13.1 kg

**Payload Total Volume:** 6440 cm

**Payload Description:** ROLSSES will use a low-frequency radio receiver system to (1) determine photoelectron sheath density and scale height, (2) acquire observations of solar and planetary radio sources from the lunar surface, (3) sense near-surface charged dust, and (4) provide a first-ever measurement of the radio environment between 10 kHz and 30 MHz at the lander. The sheath density and scale height will provide critical measurements of the plasma environment encountered by astronauts, rovers, and other exploration systems. ROLSSES measurements will also provide a much-needed baseline for future sensitive lunar radio astronomy systems.

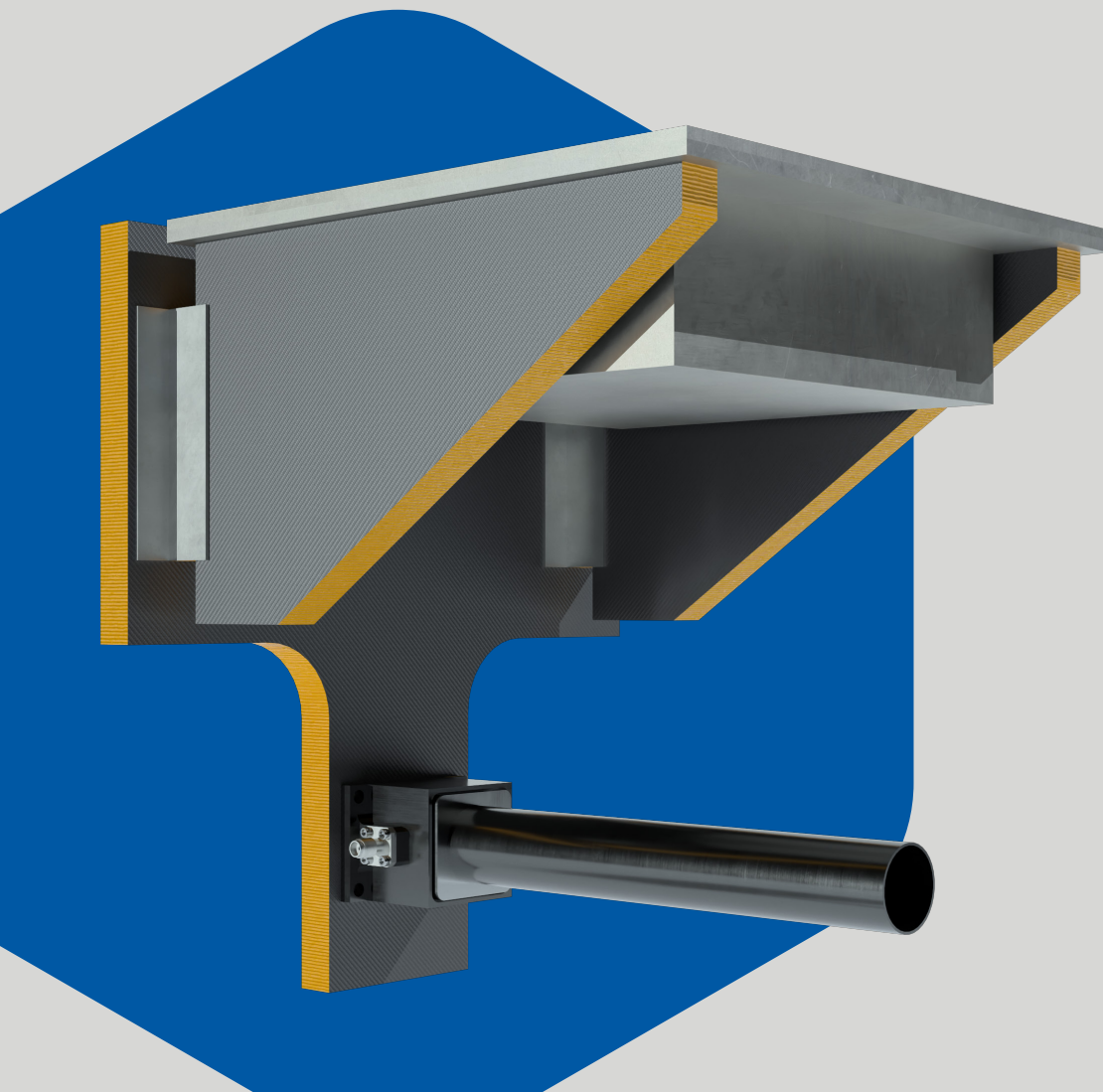

# LRA LASER RETRO-REFLECTOR ARRAY

**Lead Development Organization:** NASA Goddard Space Flight Center

**Payload Mass:** 20 g (without mounting screws)

**Payload Dimensions:** O.D. 5.1 cm x 1.65 cm tall

**Payload Description:** LRA is a collection of eight approximately half-inch retro-reflectors - a unique collection of mirrors that is used for measuring distance - mounted to the lander. The mirror system reflects laser light directly backward to the orbiting spacecraft that emitted the laser light to precisely determine the lander's location on the surface of the Moon. LRAs are valuable because they can continue to be used as precision landmarks for guidance and navigation during the lunar day or night. A few LRAs surrounding a landing site can serve as precision landmarks to guide the arriving landers by aiding in autonomous and safe landing.

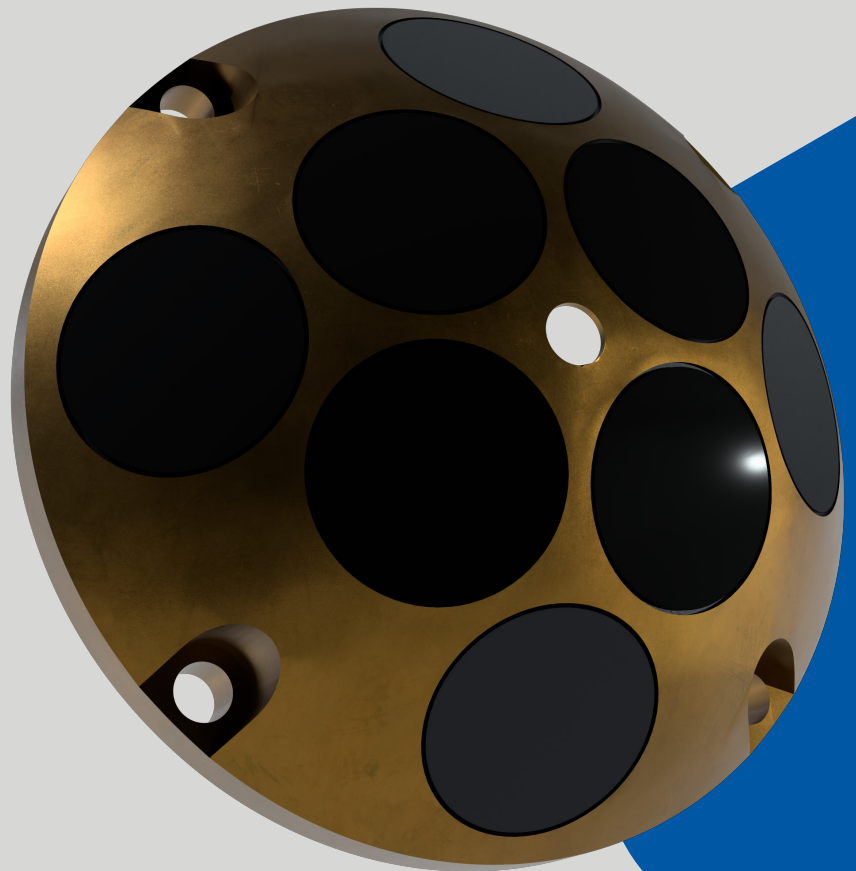

# **NDL** NAVIGATION DOPPLER LIDAR FOR PRECISE VELOCITY AND RANGE SENSING

**Lead Development Organization:** NASA Langley Research Center

**Payload Mass:** 16 kg (15 kg without MLI)

**Payload Total Volume:** 40 cm x 29 cm x 14 cm

**Payload Description:** The NDL is a LIDAR-based (Light Detection and Ranging) sensor composed of a three-beam optical head and box with electronics and photonics that will provide extremely precise velocity and range sensing during the descent and landing of the lander.

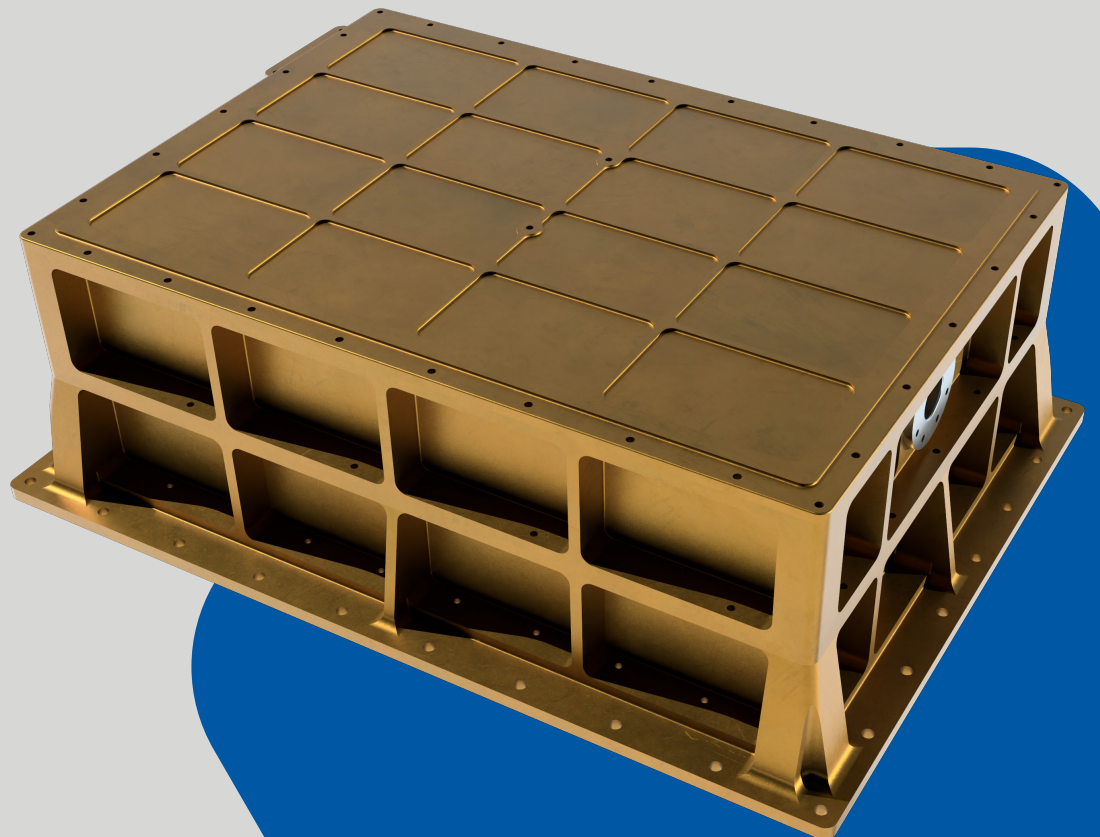

# SCALPSS

STEREO CAMERAS FOR LUNAR PLUME-SURFACE STUDIES

**Lead Development Organization:** NASA Langley Research Center

**Payload Mass:** NTE 6.0 kg

**Payload Total Volume:** SCALPSS includes 1 Data Storage Unit, 1 USB Hub, and 4 cameras

**Payload Description:** SCALPSS will capture video and still image data of the effects of the lander plume as it interacts with the lunar surface. This information is critical for validating predictive models to be used for future lunar and Mars vehicle designs to ensure the safety of both the landers and any other surface assets nearby during landing.

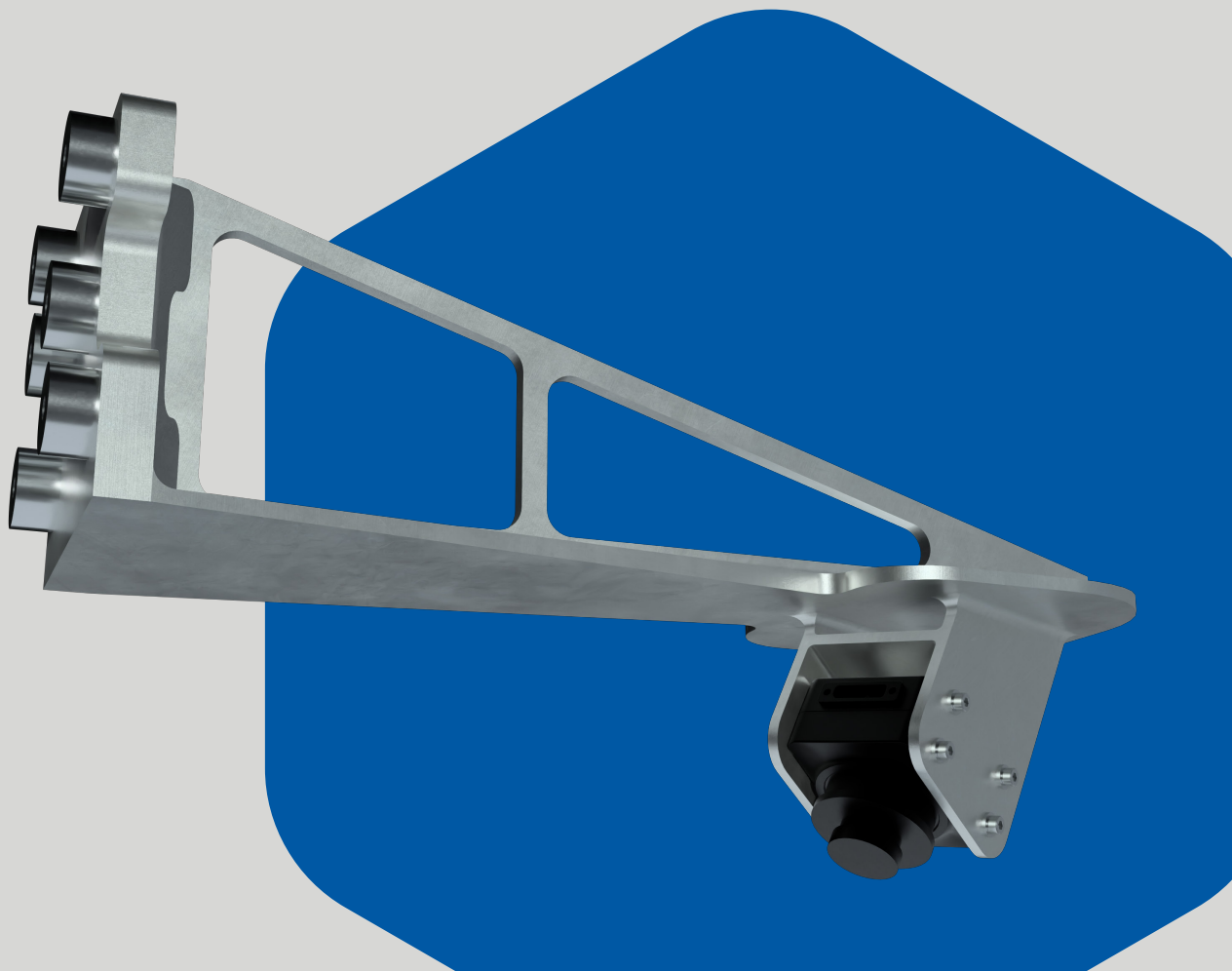

# LN-1 LUNAR NODE 1 NAVIGATION DEMONSTRATOR

**Lead Development Organization:** NASA Marshall Space Flight Center

**Payload Mass:** 2.9 kg

**Payload Total Volume:** 22 cm x 33 cm x 11 cm

**Payload Description:** LN-1 is a CubeSat-sized S-band beacon that will demonstrate autonomous spacecraft positioning through communication-integrated navigation measurements that can support future surface and orbital operations. This experiment will leverage commercial off the shelf components and Multi-spacecraft Autonomous Positioning System (MAPS) algorithms. The radio will also be used in Position, Navigation (PN) -based one-way non-coherent ranging and Doppler tracking to provide alternate approaches and comparisons for Lunar surface navigation performance.

